



GX series fieldbus module

Company Profile

Tianjin Geneuo Technology Co., Ltd. specializes in the development, production and sales of industrial automation products, system integration and engineering service.

- Communication solution
 - Industry EtherNET Switch
 - Fieldbus modules: ProfiNET, EtherNET/IP, EtherCAT, MODBUS TCP/IP I/O modules
- Inductive sensors
 - Different housing design are available:M5 to M80 and cubic
- Optimized connection technology for efficient automation
 - M5 to M40 receptacle, pre-moulding cable, field wireable connectivity
 - Passive junction box and splitters
 - Industrial network connectors for ProfiNET, EtherNET/IP, EtherCAT, MODBUS TCP/IP,Profibus,DeviceNET,CC-link.
- LED lighting
 - Machine station lighting
 - Factory lighting
 - Intelligent lighting solutions

Geneuo exceptionally large product portfolio does not only cover all relevant standard solutions but also the special requirements of individual industries. The products and the total solution have been widely used in automotive, iron & steel, machine tool, elevator, textile, packaging, rubber machine etc.

Contents

Digital I/O field bus modules

- GX_DI8 Compact modules 10
- GX_DI16 Compact modules 12
- GX_DO8 Compact modules 14
- GX_DO16 Compact modules 16
- GX_DI8DO8 Compact modules 17
- GX_DIO16 Configurable compact modules 18

Analog combined field bus modules

- GX_DI8AI4 combined modules 19
- GX_DI8AI4-0010 combined modules 20
- GX_DI8AI4-0020 combined modules 21
- GX_DI8AI4-0030 combined modules 22
- GX_DI8AI4-0090 combined modules 23
- GX_DIO8AO4-0009 combined modules 24

Accessories

- Connectors(Ethernet) 26
- Connectors(PROFIBUS-DP) 33
- Connectors(DeviceNet) 34
- Connectors(Power Supply) 36
- Connectors(I/O) 37
- Field wirable connectors 39

Index

- Index 42

■ Features

- Protection degree upto IP67- ensures most successful application on-site
- Fully sealed design- gives excellent vibration resistance feature
- Smart and compact housing- makes installation much more easier



PROFI[®]
NET

EtherNet[√]IP[™]
conformance tested

PROFI[®]
BUS

Ether**CAT[®]**

■ Communication

- Support for multiple open bus protocol
- IP67 connector design, safety and reliability
- High integration communication kernel, high-speed & stability

DeViceNet
conformance tested

Modbus TCP/IP

DI



DO



DIO



■ Signal

- Support various kinds of signals, such as: digital & analog signals
- Various signal combination function, suitable for complex signal transmission requirements
- Configurable modules for Input/Output and 4...20 mA/0...10 V signals make application much more handily

AI-I/U



AO-I/U



■ Connection

- Perfect connectors product line ensures various connection for modules
- Pre-moulding - T type - Field wirable connectors
- Various kinds of connectors, fully satisfy your different requirements

GX series modules type codes

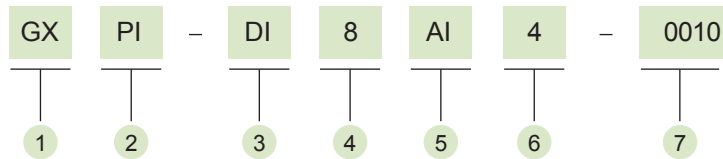

1	Product series	3	Signal types DI : Digital input DO : Digital output DIO : DI/DO configured	5	Signal types DO : Digital output AI : Analog input AO : Analog output	7	Special codes 0 0 0 0 ①②③④ ① (DI): 0-PNP, 1-NPN ② (DO): 0-0.5A, 1-2A ③ (AI): 0-I, 1-U, 2-PT, 3-TC, 9-U/I ④ (AO): 0-I, 1-U, 9-U/I
2	Communication protocol DP: PROFIBUS-DP DN: DeviceNET PI: PROFINET EN: MODBUS-TCP/IP EI: EtherNET/IP EC: EtherCAT	4	Number of channels 4 : 4 channels 8 : 8 channels 16 : 16 channels	6	Number of channels 4 : 4 channels 8 : 8 channels 16 : 16 channels		

GX series module accessories selection guide

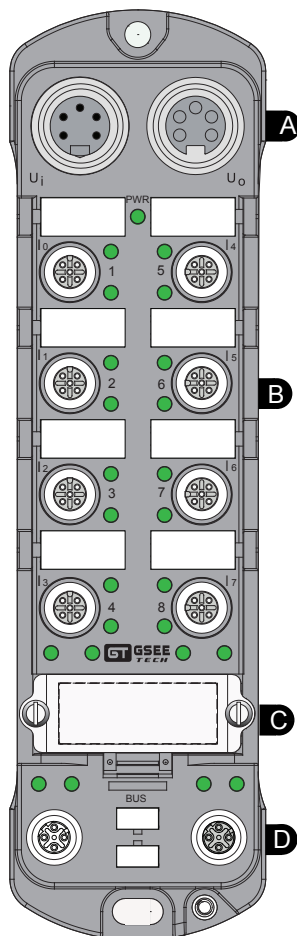

The power interface

- Each module include male and female 7/8" connectors (1 male 1 female)
- Each power supply interface including the system power supply and load power supply
- Pre-moulding/Field wireable connectors

The I/O interface

- Each module has 8 female M12 A-code I/O interface
- Each M12 interface provide power supply and signal channel
- Pre-moulding/Field wireable connectors

Station Fieldbus addressing

- No address switch with PROFINET

* Other agreement dial the code can be found in the P6 - P8

The Fieldbus interface

- Ethernet modules, each module has two male D-code M12 connectors interface
- PROFIBUS-DP, each module has two B-code M12 connectors interface (1 male 1 female)
- Devicenet , each module has two A-code M12 connectors interface (1 male 1 female)
- Pre-moulding/Field wireable connectors

■ A : Power interface

- 7/8" single-ended pre-cast plug-in (female)
(Used to connected to the module and power supply)
MK5-*M
- 7/8" double-end pre-cast plug-in
(Used for power supply connection between modules and modules)
MK5 MZ5-*M

* Details, refer to P36 , Field wirable connector, refer to P39

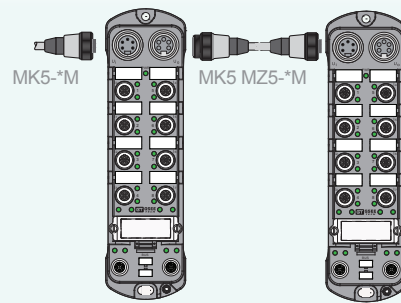

■ B : I/O interface

Single signal module (DI8、DO8)

- M12 3 pin A-code single-ended pre-cast plug-in (1 male)
(Used to connected to the terminal or the scene can be wiring connector)
EZ3-*M/P00
- M12 3 pin A code double-end pre-cast plug-in
(Used for the I/O connected to the plug-in type sensor or actuator)
EK3 EZ3-*M/P00

Dual signal module (DI16、DO16、DIO16、DI8DO8)

- M12 4 pin A-code single-ended pre-cast plug-in (1 male)
(Used to connected to the terminal or the scene can be wiring connector)
EZ4-*M/P00
- M12 4 pin A code double-end pre-cast plug-in
(With the T type for I/O with plug-in sensor or actuator connection)
EK4 EZ4-*M/P00

* Details, refer to P37 , Field wirable connector, refer to P40

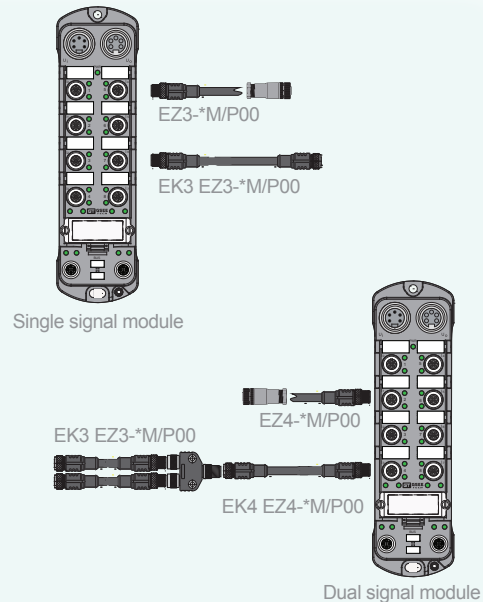

■ D : Fieldbus interface

Ethernet

- RJ45/M12 D-code male connectors
(Module-Switch/PLC)
SRJ45S EIZ4-*M/F**
- M12 Pre-moulding D-code connectors (male)
(Modules-modules)
EIZ4 EIZ4-*M/F**

PROFIBUS-DP

- M12 Pre-moulding Female B-code
(Module-PLC/IP20 Slaves)
EPK5-*M
- M12 Pre-moulding B-code
(Modules-modules)
EPK5 EPZ5-*M

DeviceNet

- M12 Pre-moulding Female A-code
(Module-PLC/IP20 Slaves)
ENK5-*M
- M12 Pre-moulding B-code
(Modules-modules)
ENK5 ENZ5-*M

* Details, refer to P26-P35

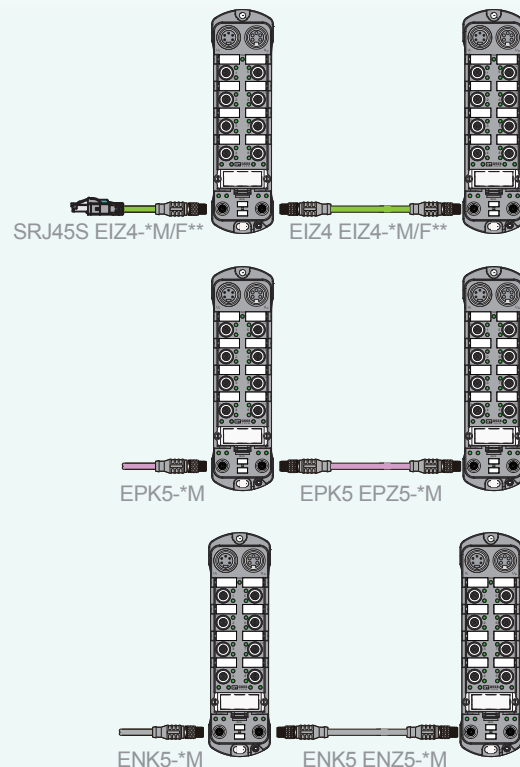

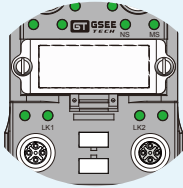

PROFINET PORT1/2

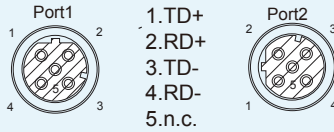

LED-Based Diagnosis

PWR	Green	OK
	Red	UL failure
MS	Green	OK
	Red	Module failure
NS	Green	OK
	Flashing green	PLC in STOP state
	Flashing Red	IP address not set
	Off	No connection with PLC
LINK	Quickly flashing green	Ethernet link established, communication present
	Slowly flashing green	Ethernet link established, no communication present
	Off	No link

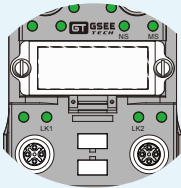

EtherNet-IP PORT1/2

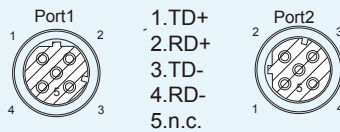

x100 x10 x1
IP Address

0	- DHCP / BOOTP
1 ... 254	- IP Address Byte 4
255	- DHCP / BOOTP

LED-Based Diagnosis

PWR	Green	OK
	Red	UL failure
	Off	No power or no IP address
NS	Green	Online, one or more connections established (CIP Class 1 or 3)
	Green, flashing	Online, no connections established
	Red	Duplicate IP address, FATAL error
	Red, flashing	One or more connections timed out (CIP Class 1 or 3)
	Off	No power
MS	Green	Controlled by a Scanner in Run state
	Green, flashing	Not configured, or Scanner in Idle state
	Red	Major fault (EXCEPTION-state, FATAL error etc.)
	Red, flashing	Recoverable fault(s). Module is configured, but stored parameters differ from currently used parameters.
LINK	Off	No link, no activity
	Green	Link (100 Mbit/s) established
	Green, flickering	Activity (100 Mbit/s)
	Yellow	Link (10 Mbit/s) established
	Yellow, flickering	Activity (10 Mbit/s)

MODBUS TCP/IP

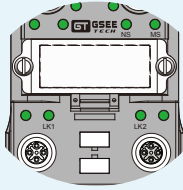

Modbus PORT1/2

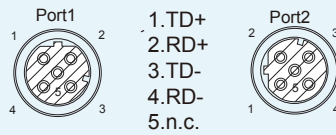

x100 x10 x1

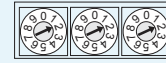

IP Address

LED-Based Diagnosis

PWR	Green	OK
	Red	UL failure
NS	Off	No IP address or Exception state
	Green	At least one Modbus message received
	Green, flashing	Waiting for first Modbus message
	Red	IP address conflict detected, FATAL ERROR
MS	Red, flashing	Connection timeout.
	Off	No power
	Green	Normal operation
	Red	Major fault, FATAL ERROR
LINK	Red, flashing	Minor fault
	Alternating Red/green	Firmware update from file system in progress
	Off	No link, no activity
	Green	Link (100 Mbit/s) established
LINK	Green, flickering	Activity (100 Mbit/s)
	Yellow	Link (10 Mbit/s) established
	Yellow, flickering	Activity (10 Mbit/s)



EtherCAT PORT1/2

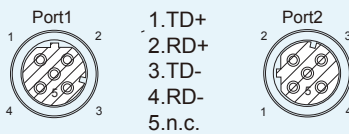
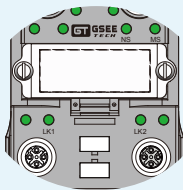

x100 x10 x1

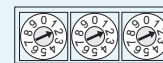

Address : 0...999

LED-Based Diagnosis

PWR	Green	OK
	Red	UL failure
NS	Off	INIT (or no power)
	Green	OPERATIONAL
	Green, blinking	PRE-OPERATIONAL
	Green, single flash	SAFE-OPERATIONAL
	Flickering	BOOT
MS	Red	(Fatal Event)
	Off	No error
	Red, blinking	Invalid configuration
	Red, single flash	Unsolicited state change
LINK	Red, double flash	Application watchdog timeout
	Red	Application controller failure
	Off	No link
	Flickering	Booting error detected
LINK	Flashing green	Link sensed, traffic detected
	Green	Link sensed, no traffic detected

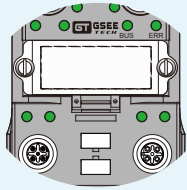

PROFIBUS-DP

Bus in (male)

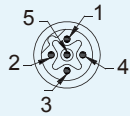

- 1-No used
- 2-Bus-A
- 3-No used
- 4-Bus-B
- 5-Shield

Bus out (female)

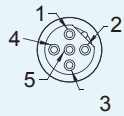

Address
0 ... 99

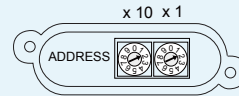

LED-Based Diagnosis

PWR	Green	OK
	Off	US failure
ERR	Off	OK
	Red	UL failure
BUS	Green	OK
	Red	PLC in STOP state

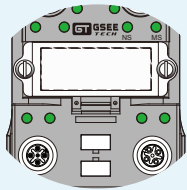

DeviceNet

Bus in (male)



- 1.Drain
- 2.+V
- 3.-V
- 4.CAN_HIGH
- 5.CAN_LOW

Bus out (female)



DR NA NA
x10 x1

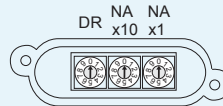

Address NA 0 ... 63

Baud rateDR 0 ... 2

DR	0	1	2
Kbit/s	125	250	500

LED-Based Diagnosis

PWR	Green	OK
	Red	UL failure
	Off	Not online / No network power
NS	Green	On-line, one or more connections are established
	Green, flashing	Online, no connections established
	Red	Critical link failure, fatal even
	Red, flashing	One or more connections timed-out
MS	Alternating Red/Green	Executing self test
	Off	Not operating
	Green	Operating in normal condition
MS	Green, flashing	Missing, incorrect or incomplete configuration, device needs commissioning.
	Red	Unrecoverable Fault(s)
	Red, flashing	Recoverable Fault(s)
	Alternating Red/Green	Executing self tes

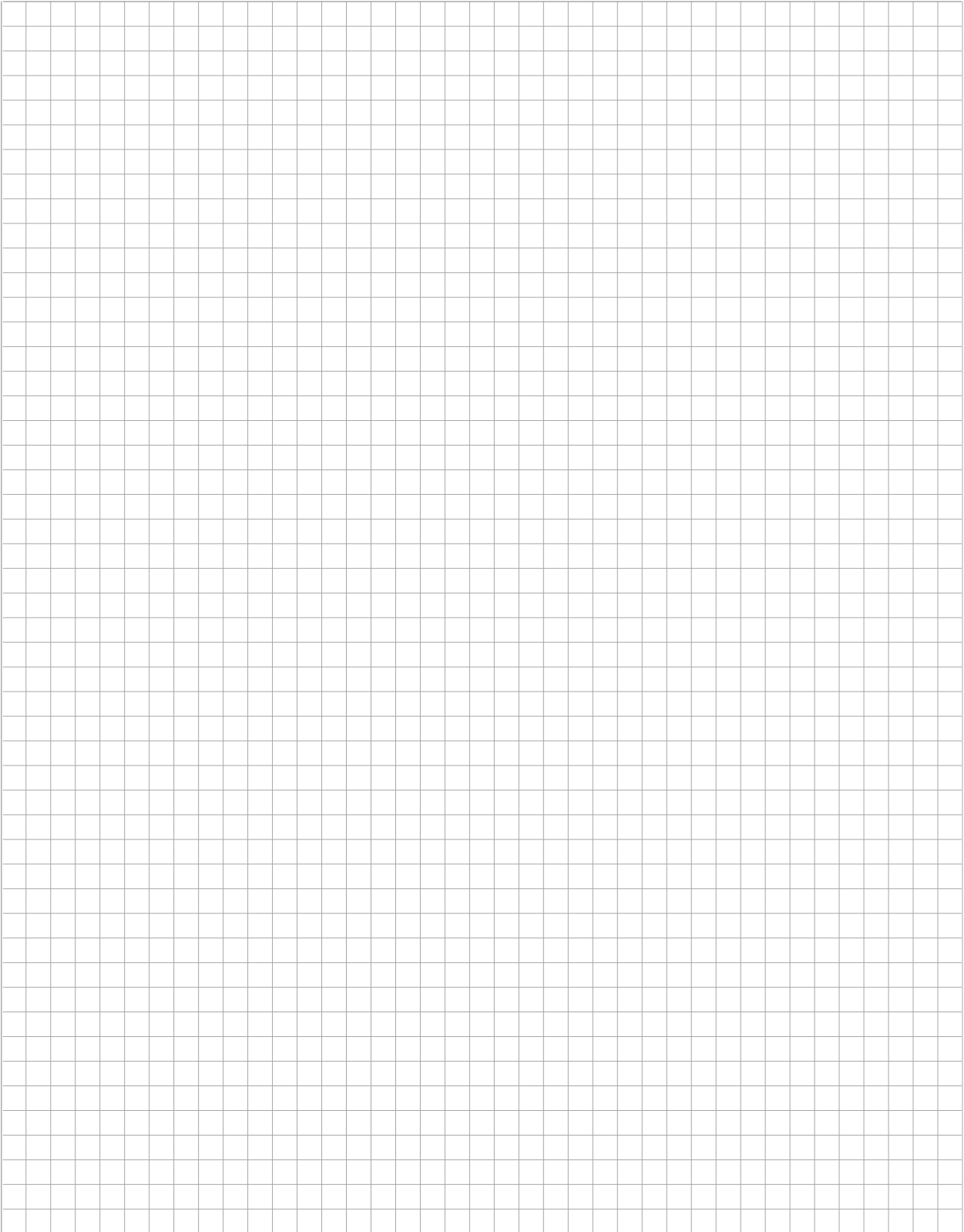

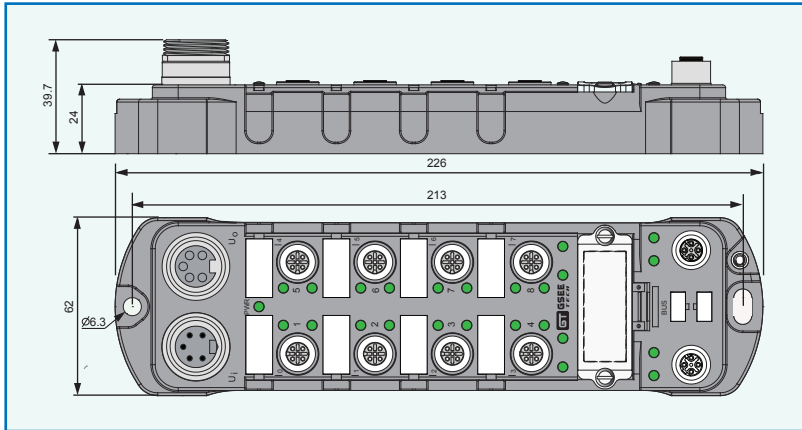

- 8 channel Digital input (PNP)
- System power supply and load power supply independently
- short circuit, overload, Reverse polarity protection
- Channel-related diagnostics
- One channel per connector
- Fibre-glass reinforced PA6 housing
- Vibration and shock-resistant
- Encapsulated module electronics
- Metal connector
- Degree of protection IP67

Technical specifications

Supply voltage	
Connection	7/8"; 5-pole; U _B max. 9 A, U _L max. 9 A
Supply voltage	24 V DC (18...30.2 V), acc. to EN61131-2
Operating current	< 120 mA
I/O-ports	
Connection	M12, A-coded
Number of inputs	8(for 3-wire sensors or mech. switches, pnp)
Input voltage	18...30 VDC
Sensor supply	24 V DC (18...30, 2V), <= 150 mA/port
Switching threshold	2 mA/4 mA
Input delay	2.5 ms
Switching frequency	≤ 250 Hz
Max. input current	100 mA
Basic data	
Dimensions (H x W x D)	226x62x24mm
Weight	515g
Housing material	Glass fiber enhanced nylon(PA6)
Installation	2*∅6.3 mm
Operating temperature	-25...+70 °C
Storage temperature	-30 ~+85 °C
Vibration tested	according to EN 60068-2-6
Shock tested	according to EN 60068-2-27
EMC	according to EN 61000-6-2, 6-4
Degree of protection	IP67
Approvals	CE

Power supply 7/8"

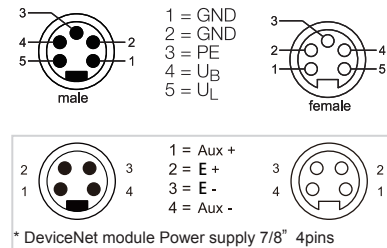

Input M12 x 1

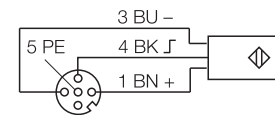

Digital input

Byte	bit0	bit1	bit2	bit3	bit4	bit5	bit6	bit7
0	C1P4	C2P4	C3P4	C4P4	C5P4	C6P4	C7P4	C8P4

"C1P4" represents the 4th pin of the 1st M12 interface in the I/O interface.

Ordering data

PROFIBUS NET	EtherCAT	EtherNet/IP <small>conformance tested</small>	MODBUS TCP/IP
GXPI-DI8	GXEC-DI8	GXEI-DI8	GXEN-DI8
PROFIBUS	DeviceNet		
GXDP-DI8	GXDN-DI8		

* Ethernet communication interface refer to P6 , PROFIBUS-DP/Device Netcommunication interface refer to P8.

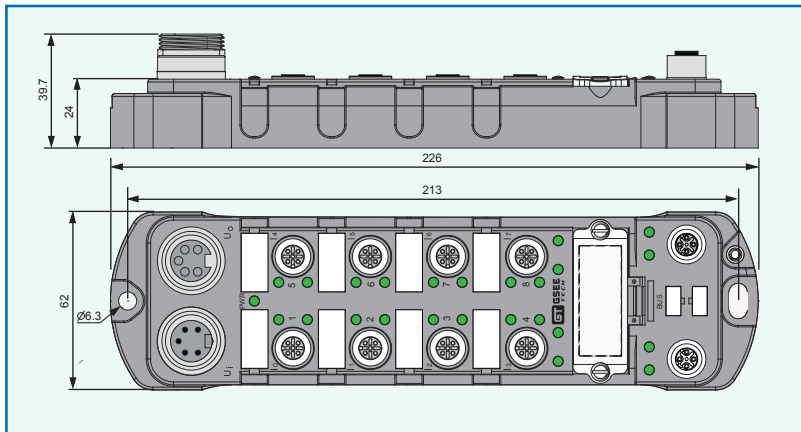

- 8 channel Digital input (NPN)
- System power supply and load power supply independently
- short circuit, overload, Reverse polarity protection
- Channel-related diagnostics
- One channel per connector
- Fibre-glass reinforced PA6 housing
- Vibration and shock-resistant
- Encapsulated module electronics
- Metal connector
- Degree of protection IP67

Technical specifications

Supply voltage	
Connection	7/8"; 5-pole; U _a max. 9 A, U _i max. 9 A
Supply voltage	24 V DC (18...30.2 V), acc. to EN61131-2
Operating current	< 120 mA
I/O-ports	
Connection	M12, A-coded
Number of inputs	8(for 3-wire sensors or mech. switches,npn)
Input voltage	18...30 VDC
Sensor supply	24 V DC (18...30, 2V), <= 150 mA/port
Switching threshold	2 mA/4 mA
Input delay	2.5 ms
Switching frequency	≤ 250 Hz
Max. input current	100 mA
Basic data	
Dimensions (H x W x D)	226x62x24mm
Weight	515g
Housing material	Glass fiber enhanced nylon(PA6)
Installation	2"∅6.3 mm
Operating temperature	-25...+70 °C
Storage temperature	-30 ~+85 °C
Vibration tested	according to EN 60068-2-6
Shock tested	according to EN 60068-2-27
EMC	according to EN 61000-6-2, 6-4
Degree of protection	IP67
Approvals	CE

Power supply 7/8"

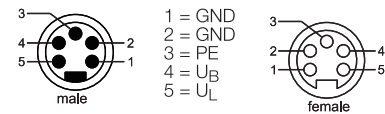

Input M12 x 1

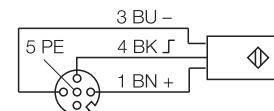

Digital input

Byte	bit0	bit1	bit2	bit3	bit4	bit5	bit6	bit7
0	C1P4	C2P4	C3P4	C4P4	C5P4	C6P4	C7P4	C8P4

"C1P4" represents the 4th pin of the 1st M12 interface in the I/O interface.

Ordering data

			MODBUS TCP/IP
GXPI-DI8-1000	GXEC-DI8-1000	GXEI-DI8-1000	GXEN-DI8-1000
GXDP-DI8-1000			

* Ethernet communication interface refer to P6 , PROFIBUS-DP/Device Netcommunication interface refer to P8.

GX_DI16 compact modules

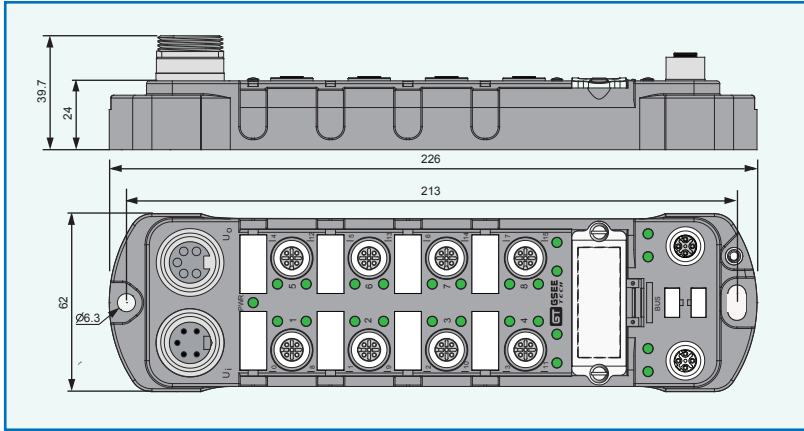

- 16 channel Digital input (PNP)
- System power supply and load power supply independently
- short circuit, overload, Reverse polarity protection
- Channel-related diagnostics
- Two channels per connector
- Fibre-glass reinforced PA6 housing
- Vibration and shock-resistant
- Encapsulated module electronics
- Metal connector
- Degree of protection IP67

Technical specifications

Supply voltage	
Connection	7/8"; 5-pole; U _B max. 9 A, U _L max. 9 A
Supply voltage	24 V DC (18...30.2 V), acc. to EN61131-2
Operating current	< 150 mA
I/O-ports	
Connection	M12, A-coded
Number of inputs	16(for 3-wire sensors or mech. switches, pnp)
Input voltage	18...30 VDC
Sensor supply	24 V DC (18...30, 2V), <= 150 mA/port
Switching threshold	2 mA/4 mA
Input delay	2.5 ms
Switching frequency	≤ 250 Hz
Max. input current	100 mA
Basic data	
Dimensions (H x W x D)	226x62x24mm
Weight	515g
Housing material	Glass fiber enhanced nylon(PA6)
Installation	2*∅6.3 mm
Operating temperature	-25...+70 °C
Storage temperature	-30 ~+85 °C
Vibration tested	according to EN 60068-2-6
Shock tested	according to EN 60068-2-27
EMC	according to EN 61000-6-2, 6-4
Degree of protection	IP67
Approvals	CE

Power supply 7/8"

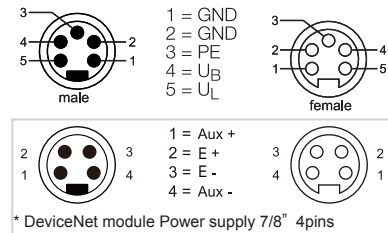

Input M12 x 1

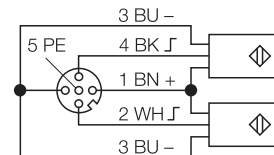

Digital input

Byte	bit0	bit1	bit2	bit3	bit4	bit5	bit6	bit7
0	C1P4	C2P4	C3P4	C4P4	C5P4	C6P4	C7P4	C8P4
1	C1P2	C2P2	C3P2	C4P2	C5P2	C6P2	C7P2	C8P2

"C1P4" represents the 4th pin of the 1st M12 interface in the I/O interface.

Ordering data

PROFIBUS	EtherCAT	EtherNet/IP	MODBUS TCP/IP
GXPI-DI16	GXEC-DI16	GXEI-DI16	GXEN-DI16
PROFIBUS	DeviceNet		
GXDP-DI16	GXDN-DI16		

* Ethernet communication interface refer to P6 , PROFIBUS-DP/Device Netcommunication interface refer to P8.

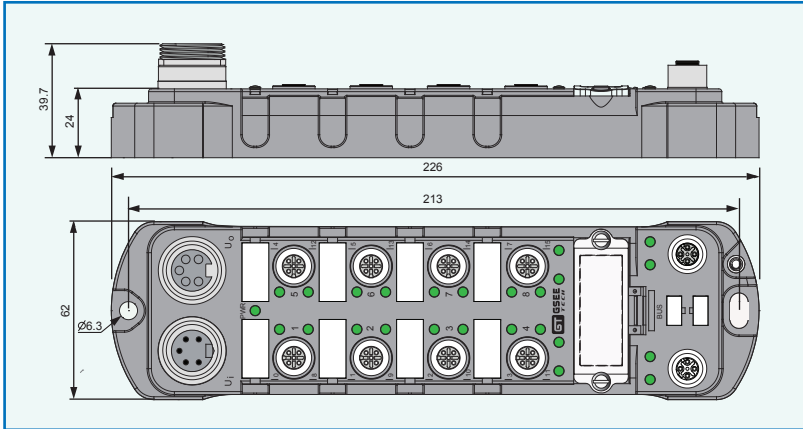

- 16 channel Digital input (NPN)
- System power supply and load power supply independently
- short circuit, overload, Reverse polarity protection
- Channel-related diagnostics
- Two channels per connector
- Fibre-glass reinforced PA6 housing
- Vibration and shock-resistant
- Encapsulated module electronics
- Metal connector
- Degree of protection IP67

Technical specifications

Supply voltage	
Connection	7/8"; 5-pole; U _B max. 9 A, U _L max. 9 A
Supply voltage	24 V DC (18...30.2 V), acc. to EN61131-2
Operating current	< 150 mA
I/O-ports	
Connection	M12, A-coded
Number of inputs	16(for 3-wire sensors or mech. switches, npn)
Input voltage	18...30 VDC
Sensor supply	24 V DC (18...30, 2V), <= 150 mA/port
Switching threshold	2 mA/4 mA
Input delay	2.5 ms
Switching frequency	≤ 250 Hz
Max. input current	100 mA
Basic data	
Dimensions (H x W x D)	226x62x24mm
Weight	515g
Housing material	Glass fiber enhanced nylon(PA6)
Installation	2*∅6.3 mm
Operating temperature	-25...+70 °C
Storage temperature	-30 ~+85 °C
Vibration tested	according to EN 60068-2-6
Shock tested	according to EN 60068-2-27
EMC	according to EN 61000-6-2, 6-4
Degree of protection	IP67
Approvals	CE

Power supply 7/8"

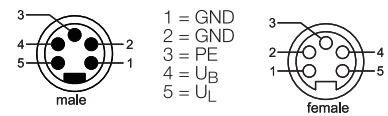

Input M12 x 1

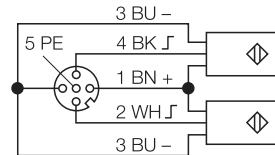

Digital input

Byte	bit0	bit1	bit2	bit3	bit4	bit5	bit6	bit7
0	C1P4	C2P4	C3P4	C4P4	C5P4	C6P4	C7P4	C8P4
1	C1P2	C2P2	C3P2	C4P2	C5P2	C6P2	C7P2	C8P2

"C1P4" represents the 4th pin of the 1st M12 interface in the I/O interface.

Ordering data

			MODBUS TCP/IP
GXPI-DI16-1000	GXEC-DI16-1000	GXEI-DI16-1000	GXEN-DI16-1000
GXDP-DI16-1000			

* Ethernet communication interface refer to P6 , PROFIBUS-DP/Device Netcommunication interface refer to P8.

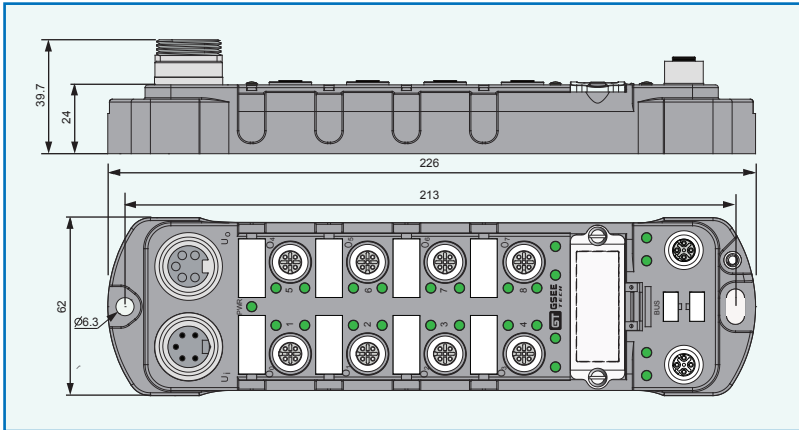

- 8 channel Digital output (0.5A)
- System power supply and load power supply independently
- short circuit, overload, Reverse polarity protection
- Channel-related diagnostics
- One channel per connector
- Fibre-glass reinforced PA6 housing
- Vibration and shock-resistant
- Encapsulated module electronics
- Metal connector
- Degree of protection IP67

Technical specifications

Supply voltage	
Connection	7/8"; 5-pole; U _B max. 9 A, U _L max. 9 A
Supply voltage	24 V DC (18...30.2 V), acc. to EN61131-2
Operating current	< 150 mA
I/O-ports	
Connection	M12, A-coded
Number of outputs	8(DC actuators)
Output voltage	18...30 VDC
Output current per channel	0.5 A, short-circuit proof
Load type	resistive, inductive, lamp load
Simultaneity factor	1
Switching frequency	≤ 250 Hz
Max. output current	0.7A/Ch. (A _{max} =8*0.7A)
Electrical isolation	galvanic isolation against the bus
Basic data	
Dimensions (H x W x D)	226x62x24mm
Weight	515g
Housing material	Glass fiber enhanced nylon(PA6)
Installation	2*Ø6.3 mm
Operating temperature	-25...+70 °C
Storage temperature	-30 ~+85 °C
Vibration tested	according to EN 60068-2-6
Shock tested	according to EN 60068-2-27
EMC	according to EN 61000-6-2, 6-4
Degree of protection	IP67
Approvals	CE

Power supply 7/8"

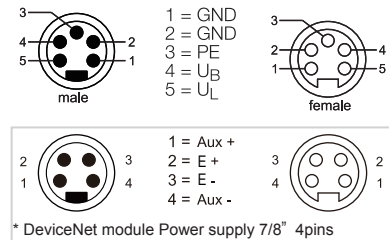

Output M12 x 1

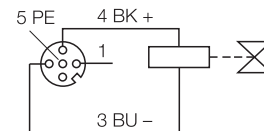

Digital output

Byte	bit0	bit1	bit2	bit3	bit4	bit5	bit6	bit7
0	C1P4	C2P4	C3P4	C4P4	C5P4	C6P4	C7P4	C8P4

"C1P4" represents the 4th pin of the 1st M12 interface in the I/O interface.

Ordering data

	EtherCAT	EtherNet/IP	MODBUS TCP/IP
GXPI-DO8	GXEC-DO8	GXEI-DO8	GXEN-DO8
	DeviceNet		
GXDP-DO8	GXDN-DO8		

* Ethernet communication interface refer to P6 , PROFIBUS-DP/Device Netcommunication interface refer to P8.

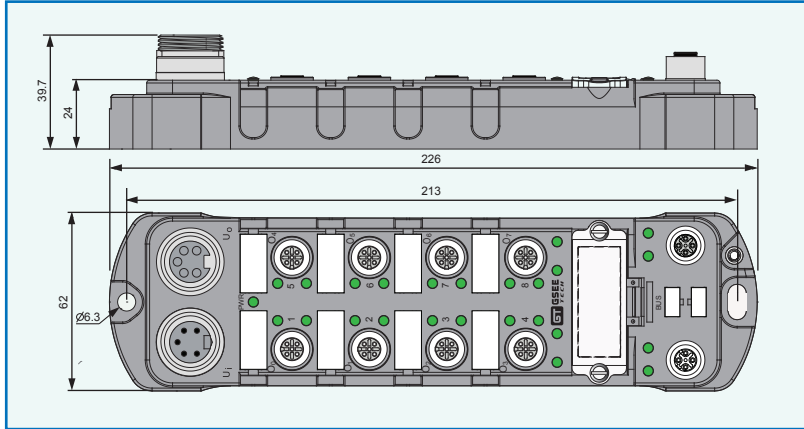

- 8 channel Digital output (2A)
- System power supply and load power supply independently
- short circuit, overload, Reverse polarity protection
- Channel-related diagnostics
- One channel per connector
- Fibre-glass reinforced PA6 housing
- Vibration and shock-resistant
- Encapsulated module electronics
- Metal connector
- Degree of protection IP67

Technical specifications

Supply voltage	
Connection	7/8"; 5-pole; U _B max. 9 A, U _L max. 9 A
Supply voltage	24 V DC (18...30.2 V), acc. to EN61131-2
Operating current	< 150 mA
I/O-ports	
Connection	M12, A-coded
Number of outputs	8(DC actuators)
Output voltage	18...30 VDC
Output current per channel	2 A, short-circuit proof
Load type	resistive, inductive, lamp load
Simultaneity factor	1
Switching frequency	≤ 250 Hz
Max. output current	2A/Ch. (Amax=4*2A)
Electrical isolation	galvanic isolation against the bus
Basic data	
Dimensions (H x W x D)	226x62x24mm
Weight	515g
Housing material	Glass fiber enhanced nylon(PA6)
Installation	2*∅6.3 mm
Operating temperature	-25...+70 °C
Storage temperature	-30 ~+85 °C
Vibration tested	according to EN 60068-2-6
Shock tested	according to EN 60068-2-27
EMC	according to EN 61000-6-2, 6-4
Degree of protection	IP67
Approvals	CE

Power supply 7/8"

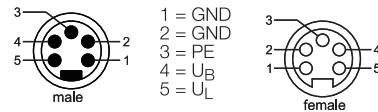

Output M12 x 1

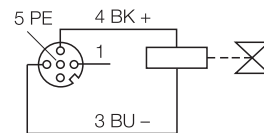

Digital output

Byte	bit0	bit1	bit2	bit3	bit4	bit5	bit6	bit7
0	C1P4	C2P4	C3P4	C4P4	C5P4	C6P4	C7P4	C8P4

"C1P4" represents the 4th pin of the 1st M12 interface in the I/O interface.

Ordering data

	EtherCAT	EtherNet/IP	MODBUS TCP/IP
GXPI-DO8-0100	GXEC-DO8-0100	GXEI-DO8-0100	GXEN-DO8-0100
GXDP-DO8-0100			

* Ethernet communication interface refer to P6 , PROFIBUS-DP/Device Netcommunication interface refer to P8.

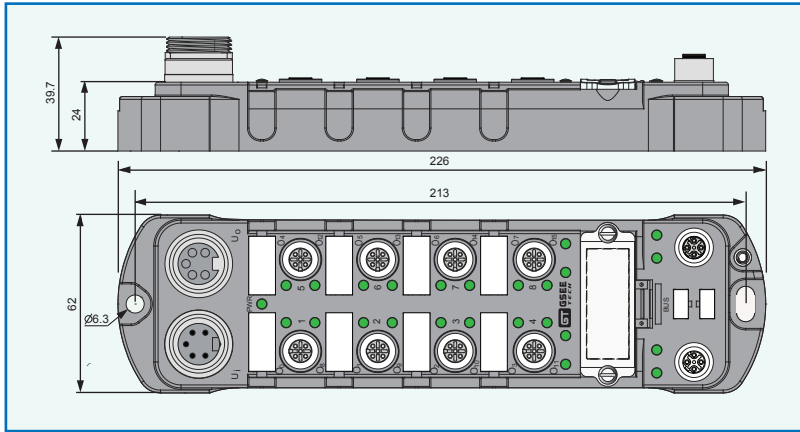

- 16 channel Digital output (0.5A)
- System power supply and load power supply independently
- short circuit, overload, Reverse polarity protection
- Channel-related diagnostics
- Two channels per connector
- Fibre-glass reinforced PA6 housing
- Vibration and shock-resistant
- Encapsulated module electronics
- Metal connector
- Degree of protection IP67

Technical specifications

Supply voltage	
Connection	7/8"; 5-pole; U _B max. 9 A, U _L max. 9 A
Supply voltage	24 V DC (18...30.2 V), acc. to EN61131-2
Operating current	< 150 mA
I/O-ports	
Connection	M12, A-coded
Number of outputs	16(DC actuators)
Output voltage	18...30 VDC
Output current per channel	0.5 A, short-circuit proof
Load type	resistive, inductive, lamp load
Simultaneity factor	1
Switching frequency	≤ 250 Hz
Max. output current	0.7A/Ch. (A _{max} =8*0.7A)
Electrical isolation	galvanic isolation against the bus
Basic data	
Dimensions (H x W x D)	226x62x24mm
Weight	515g
Housing material	Glass fiber enhanced nylon(PA6)
Installation	2*∅6.3 mm
Operating temperature	-25...+70 °C
Storage temperature	-30 ~+85 °C
Vibration tested	according to EN 60068-2-6
Shock tested	according to EN 60068-2-27
EMC	according to EN 61000-6-2, 6-4
Degree of protection	IP67
Approvals	CE

Power supply 7/8"

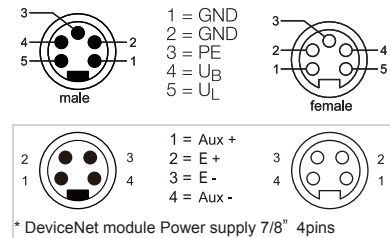

Output M12 x 1

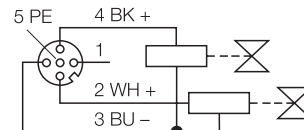

Digital output

Byte	bit0	bit1	bit2	bit3	bit4	bit5	bit6	bit7
0	C1P4	C2P4	C3P4	C4P4	C5P4	C6P4	C7P4	C8P4
1	C1P2	C2P2	C3P2	C4P2	C5P2	C6P2	C7P2	C8P2

"C1P4" represents the 4th pin of the 1st M12 interface in the I/O interface.

Ordering data

PROFIBUS	EtherCAT	EtherNet/IP	MODBUS TCP/IP
GXPI-DO16	GXEC-DO16	GXEI-DO16	GXEN-DO16
PROFIBUS	DeviceNet		
GXDP-DO16	GXDN-DO16		

* Ethernet communication interface refer to P6 , PROFIBUS-DP/Device Netcommunication interface refer to P8.

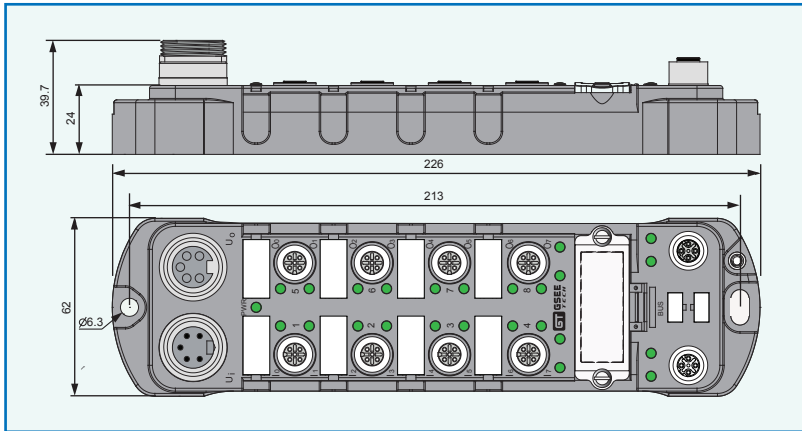

- 8 channel Digital input (PNP)
- 8 channel Digital output (0.5A)
- System power supply and load power supply independently
- Short circuit, overload, Reverse polarity protection
- Channel-related diagnostics
- Two channels per connector
- Fibre-glass reinforced PA6 housing
- Vibration and shock-resistant
- Encapsulated module electronics
- Metal connector
- Degree of protection IP67

Technical specifications

Supply voltage	
Connection	7/8"; 5-pole; U _B max. 9 A, U _L max. 9 A
Supply voltage	24 V DC (18...30.2 V), acc. to EN61131-2
Operating current	< 150 mA
I/O-ports	
Connection	M12, A-coded
Input	
Number of inputs	8(for 3-wire sensors or mech. switches, pnp)
Input voltage	18...30 VDC
Sensor supply	24 V DC (18...30, 2V), <= 150 mA/port
Switching threshold	2 mA/4 mA
Input delay	2.5 ms
Switching frequency	≤ 250 Hz
Max. input current	100 mA
Output	
Number of outputs	8(DC actuators)
Output voltage	18...30 VDC
Output current per channel	0.5 A, short-circuit proof
Load type	resistive, inductive, lamp load
Simultaneity factor	1
Switching frequency	≤ 250 Hz
Max. output current	0.7A/Ch. (A _{max} =8*0.7A)
Electrical isolation	galvanic isolation against the bus
Basic data	
Dimensions (H x W x D)	226x62x24mm
Weight	515g
Housing material	Glass fiber enhanced nylon(PA6)
Installation	2*∅6.3 mm
Operating temperature	-25...+70 °C
Storage temperature	-30 ~+85 °C
Vibration tested	according to EN 60068-2-6
Shock tested	according to EN 60068-2-27
EMC	according to EN 61000-6-2, 6-4
Degree of protection	IP67
Approvals	CE

Power supply 7/8"

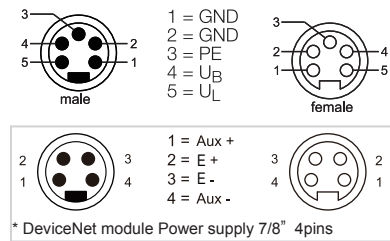

Input M12 x 1

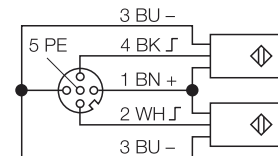

Output M12 x 1

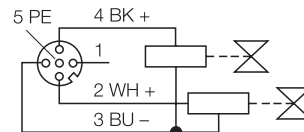

Digital input/output

Byte	bit0	bit1	bit2	bit3	bit4	bit5	bit6	bit7
DI0	C1P4	C1P2	C2P4	C2P2	C3P4	C3P2	C4P4	C4P2
DO0	C5P4	C5P2	C6P4	C6P2	C7P4	C7P2	C8P4	C8P2

"C1P4" represents the 4th pin of the 1st M12 interface in the I/O interface.

Ordering data

PROFIBUS	EtherCAT	EtherNet/IP	MODBUS TCP/IP
GXPI-DI8DO8	GXEC-DI8DO8	GXEI-DI8DO8	GXEN-DI8DO8
PROFIBUS	DeviceNet		
GXDP-DI8DO8	GXDN-DI8DO8		

* Ethernet communication interface refer to P6 , PROFIBUS-DP/Device Netcommunication interface refer to P8.

GX_DIO16 Configurable compact modules

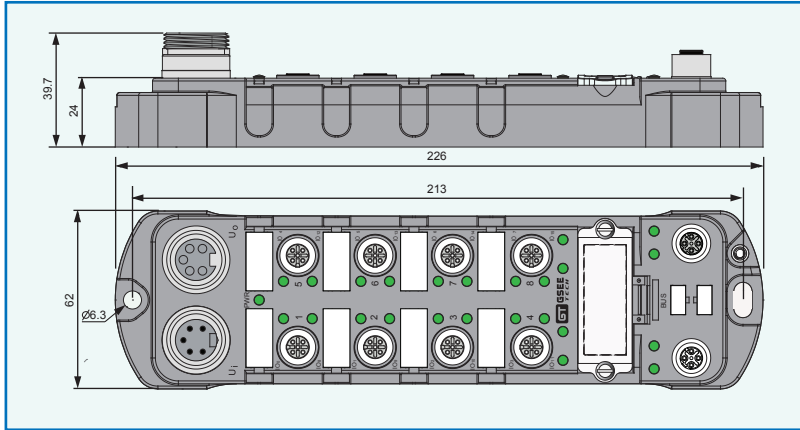

- 16 configurable digital channels
- Input/output adaptive
- PNP inputs / outputs 0.5 A
- System power supply and load power supply independently
- Short circuit, overload, Reverse polarity protection
- Channel-related diagnostics
- Two channels per connector
- Fibre-glass reinforced PA6 housing
- Vibration and shock-resistant
- Encapsulated module electronics
- Metal connector
- Degree of protection IP67

Technical specifications

Supply voltage	
Connection	7/8"; 5-pole; U _B max. 9 A, U _L max. 9 A
Supply voltage	24 V DC (18...30.2 V), acc. to EN61131-2
Operating current	< 180 mA
I/O-ports	
Connection	M12, A-coded
Input	
Number of inputs	16(for 3-wire sensors or mech. switches, pnp)
Input voltage	18...30 VDC
Sensor supply	24 V DC (18...30, 2V), <= 150 mA/port
Switching threshold	2 mA/4 mA
Input delay	2.5 ms
Switching frequency	≤ 250 Hz
Max. input current	100 mA
Output	
Number of outputs	16(DC actuators)
Output voltage	18...30 VDC
Output current per channel	0.5 A, short-circuit proof
Load type	resistive, inductive, lamp load
Simultaneity factor	1
Switching frequency	≤ 250 Hz
Max. output current	0.7A/Ch. (A _{max} =8*0.7A)
Electrical isolation	galvanic isolation against the bus
Basic data	
Dimensions (H x W x D)	226x62x24mm
Weight	515g
Housing material	Glass fiber enhanced nylon(PA6)
Installation	2*∅6.3 mm
Operating temperature	-25...+70 °C
Storage temperature	-30 ~+85 °C
Vibration tested	according to EN 60068-2-6
Shock tested	according to EN 60068-2-27
EMC	according to EN 61000-6-2, 6-4
Degree of protection	IP67
Approvals	CE

Power supply 7/8"

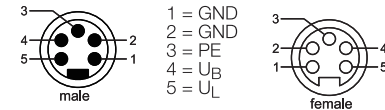

Input M12 x 1

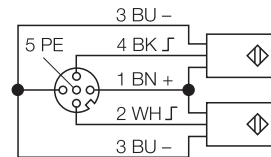

Output M12 x 1

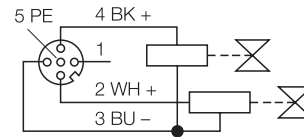

Digital input

Byte	bit0	bit1	bit2	bit3	bit4	bit5	bit6	bit7
0	C1P4	C2P4	C3P4	C4P4	C5P4	C6P4	C7P4	C8P4
1	C1P2	C2P2	C3P2	C4P2	C5P2	C6P2	C7P2	C8P2

Digital output

Byte	bit0	bit1	bit2	bit3	bit4	bit5	bit6	bit7
0	C1P4	C2P4	C3P4	C4P4	C5P4	C6P4	C7P4	C8P4
1	C1P2	C2P2	C3P2	C4P2	C5P2	C6P2	C7P2	C8P2

*"C1P4" represents the 4th pin of the 1st M12 interface in the I/O interface.

Ordering data

PROFIBUS	EtherCAT	EtherNet/IP	MODBUS TCP/IP
GXPI-DIO16	GXEC-DIO16	GXEI-DIO16	GXEN-DIO16
PROFIBUS			
GXDP-DIO16			

* Ethernet communication interface refer to P6 , PROFIBUS-DP/Device Netcommunication interface refer to P8.

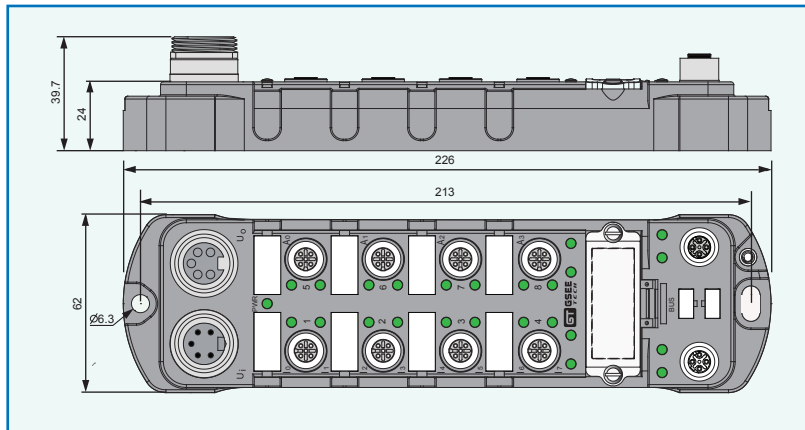

- 8 channel Digital input (PNP)
- 4 channel analog current inputs
- System power supply and load power supply independently
- Short circuit, overload, Reverse polarity protection
- Channel-related diagnostics
- Two channels per connector(DI)
- Fibre-glass reinforced PA6 housing
- Vibration and shock-resistant
- Encapsulated module electronics
- Metal connector
- Degree of protection IP67

Technical specifications

Supply voltage	
Connection	7/8"; 5-pole; U _B max. 9 A, U _L max. 9 A
Supply voltage	24 V DC (18...30.2 V), acc. to EN61131-2
Operating current	< 150 mA
I/O-ports	
Connection	M12, A-coded
Digital input	
Number of channels	8(for 3-wire sensors or mech. switches, pnp)
Input voltage	18...30 VDC
Sensor supply	24 V DC (18...30, 2V), <= 150 mA/port
Switching threshold	2 mA/4 mA
Input delay	2.5 ms
Switching frequency	≤ 250 Hz
Max. input current	100 mA
Analog input	
Number of channels	4
Input resistance	approx. 100Ohm, difference input
Sensor supply	<200 mA/port
Measuring ranges	0 / 4...20mA
Resolution/Data(DEC)	12bit (0-4095)/ 16bit(0-32767)
Conversion time	approx. 10ms per channel
Sensor power supply	24VDC (18...30.2V)
Basic data	
Dimensions (H x W x D)	226x62x24mm
Weight	515g
Housing material	Glass fiber enhanced nylon(PA6)
Installation	2*∅6.3 mm
Operating temperature	-25...+70 °C
Storage temperature	-30 ~+85 °C
Vibration tested	according to EN 60068-2-6
Shock tested	according to EN 60068-2-27
EMC	according to EN 61000-6-2, 6-4
Degree of protection	IP67
Approvals	CE

Power supply 7/8"

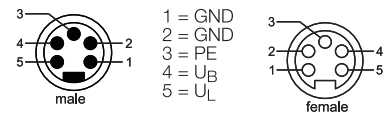

Digital input M12 x 1

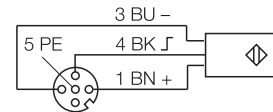

Analog input M12 x 1

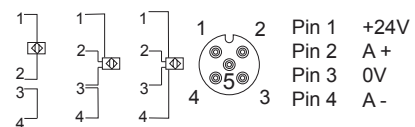

Digital input

Byte	bit0	bit1	bit2	bit3	bit4	bit5	bit6	bit7
0	C1P4	C1P2	C2P4	C2P2	C3P4	C3P2	C4P4	C4P2

* "C1P4" represents the 4th pin of the 1st M12 interface in the I/O interface.

Analog input

Add.	Byte0	Byte1	Byte2	Byte3	Byte4	Byte5	Byte6	Byte7
Ch.	C5(A0)	C6(A1)	C7(A2)	C8(A3)				

* "C5 (A0)" means that the 5 M12 interface in the I/O interface is AI0.

Ordering data

PROFIBUS DP	EtherCAT	EtherNet/IP	PROFIBUS DP
GXPI-DI8AI4	GXEC-DI8AI4	GXEI-DI8AI4	GXDP-DI8AI4

* Ethernet communication interface refer to P6 , PROFIBUS-DP/Device Netcommunication interface refer to P8.

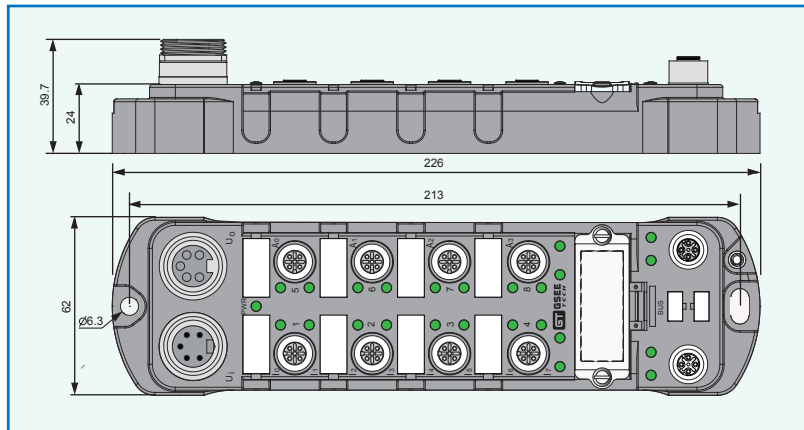

- 8 channel Digital input (PNP)
- 4 channel analog Voltage inputs
- System power supply and load power supply independently
- Short circuit, overload, Reverse polarity protection
- Channel-related diagnostics
- Two channels per connector(DI)
- Fibre-glass reinforced PA6 housing
- Vibration and shock-resistant
- Encapsulated module electronics
- Metal connector
- Degree of protection IP67

Technical specifications

Supply voltage	
Connection	7/8"; 5-pole; U _B max. 9 A, U _L max. 9 A
Supply voltage	24 V DC (18...30.2 V), acc. to EN61131-2
Operating current	< 150 mA
I/O-ports	
Connection	M12, A-coded
Digital input	
Number of channels	8(for 3-wire sensors or mech. switches, pnp)
Input voltage	18...30 VDC
Sensor supply	24 V DC (18...30, 2V), <= 150 mA/port
Switching threshold	2 mA/4 mA
Input delay	2.5 ms
Switching frequency	≤ 250 Hz
Max. input current	100 mA
Analog input	
Number of channels	4
Input resistance	< 100 kΩ
Sensor supply	<120 mA/port
Measuring ranges	-10/0 ... +10 VDC
Resolution/Data(DEC)	12bit (0-4095)/ 16bit(0-32767)
Conversion time	approx. 5ms per channel
Sensor power supply	24VDC (18...30.2V)
Basic data	
Dimensions (H x W x D)	226x62x24mm
Weight	515g
Housing material	Glass fiber enhanced nylon(PA6)
Installation	2*∅6.3 mm
Operating temperature	-25...+70 °C
Storage temperature	-30 ~+85 °C
Vibration tested	according to EN 60068-2-6
Shock tested	according to EN 60068-2-27
EMC	according to EN 61000-6-2, 6-4
Degree of protection	IP67
Approvals	CE

Power supply 7/8"

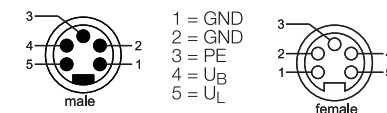

M12 Digital input

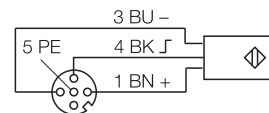

M12 Analog input

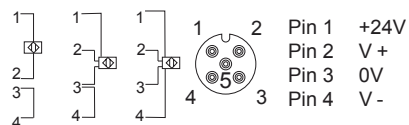

Digital input

Byte	bit0	bit1	bit2	bit3	bit4	bit5	bit6	bit7
0	C1P4	C1P2	C2P4	C2P2	C3P4	C3P2	C4P4	C4P2

* "C1P4" represents the 4th pin of the 1st M12 interface in the I/O interface.

Analog input

Addr.	Byte0	Byte1	Byte2	Byte3	Byte4	Byte5	Byte6	Byte7
Ch.	C5(A0)	C6(A1)	C7(A2)	C8(A3)				

* "C5 (A0)" means that the 5 M12 interface in the I/O interface is A10.

Ordering data

GXPI-DI8AI4-0010	GXEC-DI8AI4-0010	GXEI-DI8AI4-0010	GXDP-DI8AI4-0010

* Ethernet communication interface refer to P6 , PROFIBUS-DP/Device Netcommunication interface refer to P8.

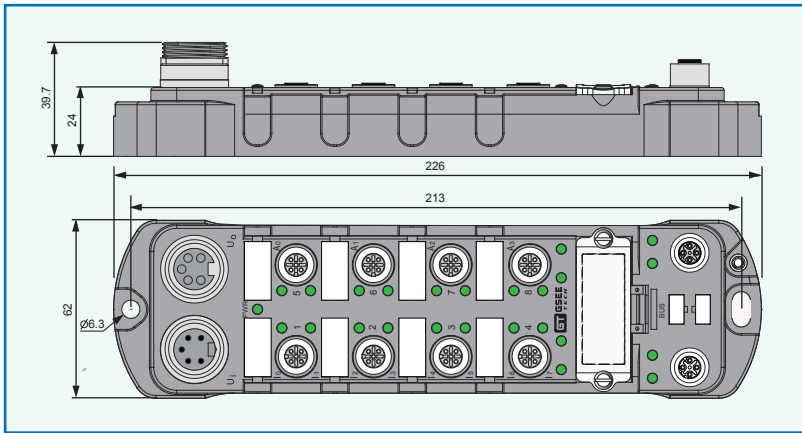

- 8 channel Digital input (PNP)
- 4 channel analog RTD inputs
- System power supply and load power supply independently
- Short circuit, overload, Reverse polarity protection
- Channel-related diagnostics
- Two channels per connector(DI)
- Fibre-glass reinforced PA6 housing
- Vibration and shock-resistant
- Encapsulated module electronics
- Metal connector
- Degree of protection IP67

Technical specifications

Supply voltage	
Connection	7/8"; 5-pole; U _B max. 9 A, U _L max. 9 A
Supply voltage	24 V DC (18...30.2 V), acc. to EN61131-2
Operating current	< 150 mA
I/O-ports	
Connection	M12, A-coded
Digital input	
Number of channels	8(for 3-wire sensors or mech. switches, pnp)
Input voltage	18...30 VDC
Sensor supply	24 V DC (18...30, 2V), <= 150 mA/port
Switching threshold	2 mA/4 mA
Input delay	2.5 ms
Switching frequency	≤ 250 Hz
Max. input current	100 mA
Analog input	
Number of channels	4
Input type	Pt100, Pt200, Pt500, Pt1000, Ni100, Ni1000 0...100Ω, 0...200Ω, 0...400Ω, 0...1000Ω
Basic fault limit at 23 °C	< 0.2 %
Repeatability	0.05 %
Temperature coefficient	< 300 ppm/°C of full scale
Resolution	16Bit
Measured-value display	16 bit signed integer
Cycle time	approx. 20ms per channel
Basic data	
Dimensions (H x W x D)	226x62x24mm
Weight	515g
Housing material	Glass fiber enhanced nylon(PA6)
Installation	2*∅6.3 mm
Operating temperature	-25...+70 °C
Storage temperature	-30 ~+85 °C
Vibration tested	according to EN 60068-2-6
Shock tested	according to EN 60068-2-27
EMC	according to EN 61000-6-2, 6-4
Degree of protection	IP67
Approvals	CE

Power supply 7/8"

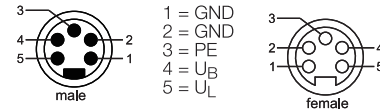

Digital input M12 x 1

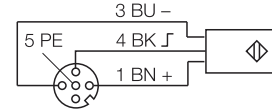

Analog input M12 x 1

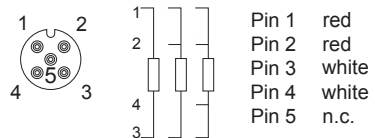

Digital input

Byte	bit0	bit1	bit2	bit3	bit4	bit5	bit6	bit7
0	C1P4	C1P2	C2P4	C2P2	C3P4	C3P2	C4P4	C4P2

* "C1P4" represents the 4th pin of the 1st M12 interface in the I/O interface.

Analog input

Addr.	Byte0	Byte1	Byte2	Byte3	Byte4	Byte5	Byte6	Byte7
Ch.	C5(A0)	C6(A1)	C7(A2)	C8(A3)				

* "C5 (A0)" means that the 5 M12 interface in the I/O interface is AI0.

Ordering data

PROFI NET	EtherCAT	EtherNet/IP	PROFI BUS
GXPI-DI8AI4-0020	GXEC-DI8AI4-0020	GXEI-DI8AI4-0020	GXDP-DI8AI4-0020

* Ethernet communication interface refer to P6 , PROFIBUS-DP/Device Netcommunication interface refer to P8.

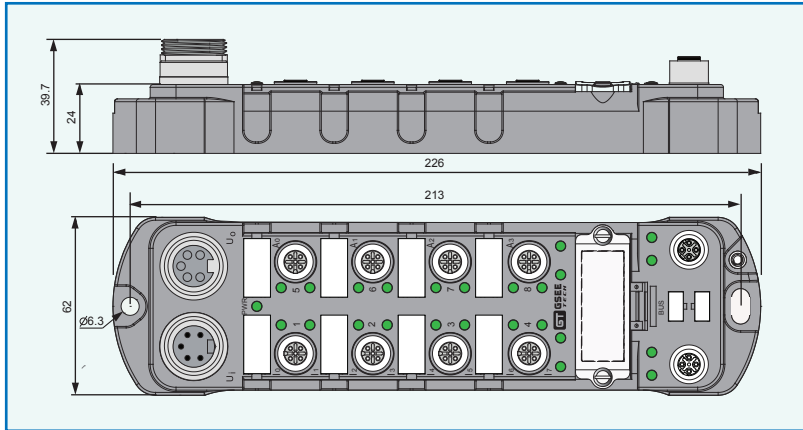

- 8 channel Digital input (PNP)
- 4 channel analog TC inputs
- System power supply and load power supply independently
- Short circuit, overload, Reverse polarity protection
- Channel-related diagnostics
- Two channels per connector(DI)
- Fibre-glass reinforced PA6 housing
- Vibration and shock-resistant
- Encapsulated module electronics
- Metal connector
- Degree of protection IP67

Technical specifications

Supply voltage	
Connection	7/8"; 5-pole; U _B max. 9 A, U _L max. 9 A
Supply voltage	24 V DC (18...30.2 V), acc. to EN61131-2
Operating current	< 150 mA
I/O-ports	
Connection	M12, A-coded
Digital input	
Number of channels	8(for 3-wire sensors or mech. switches, pnp)
Input voltage	18...30 VDC
Sensor supply	24 V DC (18...30, 2V), <= 150 mA/port
Switching threshold	2 mA/4 mA
Input delay	2.5 ms
Switching frequency	≤ 250 Hz
Max. input current	100 mA
Analog input	
Number of channels	4
Input type	types E / S / J / T / K / B / N / C / R / L
Basic fault limit at 23 °C	< 0.2 %
Repeatability	0.05 %
Temperature coeffi cient	<300 ppm/°C
Resolution	16bit
Measured-value display	16 bit signed integer
Conversion time	approx. 20ms per channel
Basic data	
Dimensions (H x W x D)	226x62x24mm
Weight	515g
Housing material	Glass fiber enhanced nylon(PA6)
Installation	2*Ø6.3 mm
Operating temperature	-25...+70 °C
Storage temperature	-30 ~+85 °C
Vibration tested	according to EN 60068-2-6
Shock tested	according to EN 60068-2-27
EMC	according to EN 61000-6-2, 6-4
Degree of protection	IP67
Approvals	CE

Power supply 7/8"

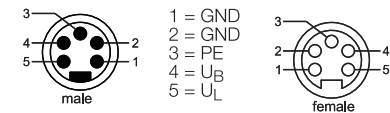

Digital input M12 x 1

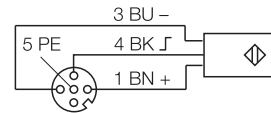

Analog input M12 x 1

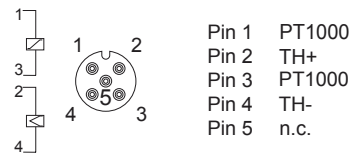

Digital input

Byte	bit0	bit1	bit2	bit3	bit4	bit5	bit6	bit7
0	C1P4	C1P2	C2P4	C2P2	C3P4	C3P2	C4P4	C4P2

* "C1P4" represents the 4th pin of the 1st M12 interface in the I/O interface.

Analog input

Addr.	Byte0	Byte1	Byte2	Byte3	Byte4	Byte5	Byte6	Byte7
Ch.	C5(A0)	C6(A1)	C7(A2)	C8(A3)				

* "C5 (A0)" means that the 5 M12 interface in the I/O interface is A10.

Ordering data

PROFIBUS NETT	EtherCAT	EtherNet/IP	PROFIBUS
GXPI-DI8AI4-0030	GXEC-DI8AI4-0030	GXEI-DI8AI4-0030	GXDP-DI8AI4-0030

* Ethernet communication interface refer to P6 , PROFIBUS-DP/Device Netcommunication interface refer to P8.

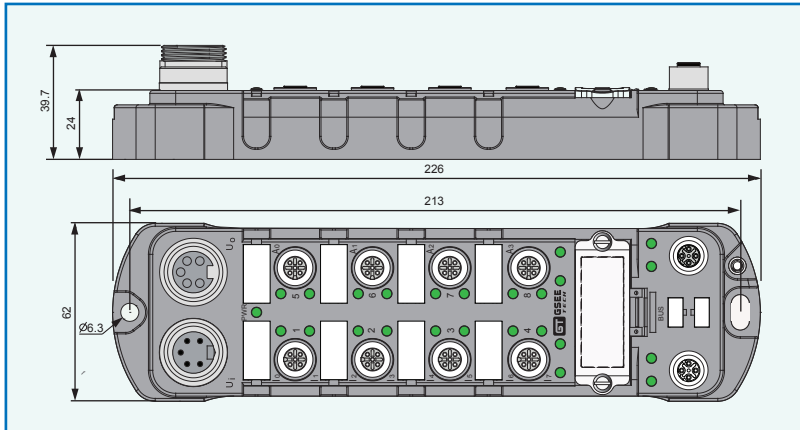

- 8 channel Digital input (PNP)
- 4 channel analog current/Voltage inputs
- System power supply and load power supply independently
- Short circuit, overload, Reverse polarity protection
- Channel-related diagnostics
- Two channels per connector(DI)
- Fibre-glass reinforced PA6 housing
- Vibration and shock-resistant
- Encapsulated module electronics
- Metal connector
- Degree of protection IP67

Technical specifications

Supply voltage	
Connection	7/8"; 5-pole; U _B max. 9 A, U _L max. 9 A
Supply voltage	24 V DC (18...30.2 V), acc. to EN61131-2
Operating current	< 150 mA
I/O-ports	
Connection	M12, A-coded
Digital input	
Number of channels	8(for 3-wire sensors or mech. switches, pnp)
Input voltage	18...30 VDC
Sensor supply	24 V DC (18...30, 2V), <= 150 mA/port
Switching threshold	2 mA/4 mA
Input delay	2.5 ms
Switching frequency	≤ 250 Hz
Max. input current	100 mA
Analog input(I/U)	
Number of channels	4
Input resistance	approx. 100Ohm, difference input
Sensor supply	<200 mA/port
Measuring ranges	0 / 4...20mA(I) , -10/0 ... +10 VDC(U)
Resolution/Data(DEC)	12bit (0-4095)/ 16bit(0-32767)
Conversion time	approx. 10ms per channel
Sensor power supply	24VDC (18...30.2V)
Basic data	
Dimensions (H x W x D)	226x62x24mm
Weight	515g
Housing material	Glass fiber enhanced nylon(PA6)
Installation	2*∅6.3 mm
Operating temperature	-25...+70 °C
Storage temperature	-30 ~+85 °C
Vibration tested	according to EN 60068-2-6
Shock tested	according to EN 60068-2-27
EMC	according to EN 61000-6-2, 6-4
Degree of protection	IP67
Approvals	CE

Power supply 7/8"

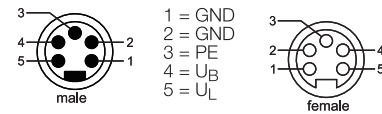

Digital input M12 x 1

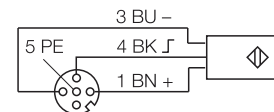

Analog input M12 x 1

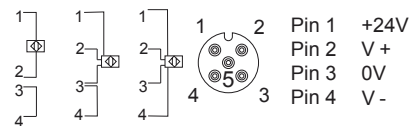

Digital input

Byte	bit0	bit1	bit2	bit3	bit4	bit5	bit6	bit7
0	C1P4	C1P2	C2P4	C2P2	C3P4	C3P2	C4P4	C4P2

* "C1P4" represents the 4th pin of the 1st M12 interface in the I/O interface.

Analog input

Addr.	Byte0	Byte1	Byte2	Byte3	Byte4	Byte5	Byte6	Byte7
Ch.	C5(A0)	C6(A1)	C7(A2)	C8(A3)				

* "C5 (A0)" means that the 5 M12 interface in the I/O interface is A10.

Ordering data

GXPI-DI8AI4-0090	GXEC-DI8AI4-0090	GXEI-DI8AI4-0090	GXDP-DI8AI4-0090

* Ethernet communication interface refer to P6 , PROFIBUS-DP/Device Netcommunication interface refer to P8.

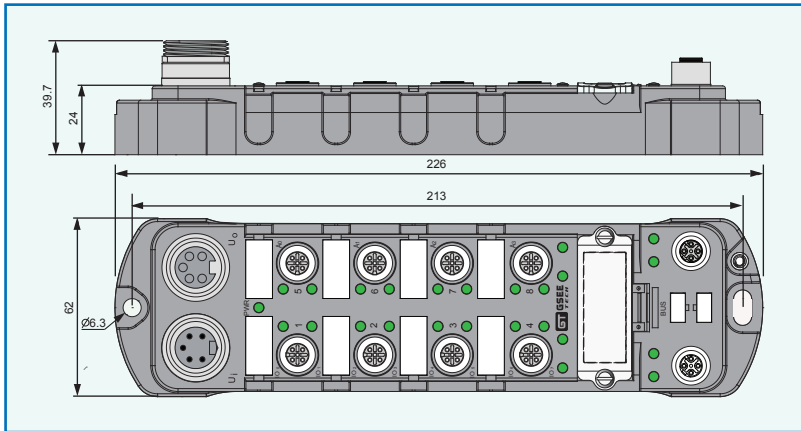

- 8 configurable digital channels
- 4 channel analog current/Voltage outputs
- PNP inputs / outputs 0.5 A
- System power supply and load power supply independently
- Short circuit, overload, Reverse polarity protection
- Channel-related diagnostics
- Two channels per connector
- Fibre-glass reinforced PA6 housing
- Vibration and shock-resistant
- Encapsulated module electronics
- Metal connector
- Degree of protection IP67

Technical specifications

Supply voltage	
Connection	7/8"; 5-pole; U _B max. 9 A, U _L max. 9 A
Supply voltage	24 V DC (18...30.2 V), acc. to EN61131-2
Operating current	< 180 mA
I/O-ports	
Connection	M12, A-coded
Input	
Number of inputs	8 (for 3-wire sensors or mech. switches, pnp)
Input voltage	18...30 VDC
Sensor supply	24 V DC (18...30, 2V), <= 150 mA/port
Switching threshold	2 mA/4 mA
Input delay	2.5 ms
Switching frequency	≤ 250 Hz
Max. input current	100 mA
Output	
Number of outputs	8 (DC actuators)
Output voltage	18...30 VDC
Output current per channel	0.5 A, short-circuit proof
Load type	resistive, inductive, lamp load
Simultaneity factor	1
Switching frequency	≤ 250 Hz
Max. output current	0.7A/Ch. (A _{max} =8*0.7A)
Electrical isolation	galvanic isolation against the bus

Input M12 x 1

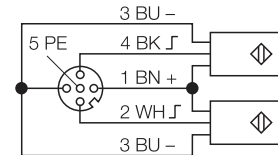

Output M12 x 1

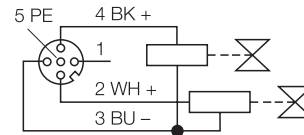

Digital input

Byte	bit0	bit1	bit2	bit3	bit4	bit5	bit6	bit7
0	C1P4	C1P2	C2P4	C2P2	C3P4	C3P2	C4P4	C4P2

Digital output

Byte	bit0	bit1	bit2	bit3	bit4	bit5	bit6	bit7
0	C1P4	C1P2	C2P4	C2P2	C3P4	C3P2	C4P4	C4P2

"C1P4" represents the 4th pin of the 1st M12 interface in the I/O interface.

Analog input(I/U)	
Number of channels	4
Resistance	$\geq 500\Omega(I) / \geq 1\text{ k}\Omega(U)$
Output type	0 / 4...20mA(I) , -10/0 ... +10 VDC(U)
Resolution/Data(DEC)	12Bit (0-4095) /16Bit (0-32767)
Conversion time	approx. 10ms per channel
Sensor power supply	24VDC(18...30.2V)
Basic data	
Dimensions (H x W x D)	226x62x24mm
Weight	515g
Housing material	Glass fiber enhanced nylon(PA6)
Installation	2* \varnothing 6.3 mm
Operating temperature	-25...+70 °C
Storage temperature	-30 ~+85 °C
Vibration tested	according to EN 60068-2-6
Shock tested	according to EN 60068-2-27
EMC	according to EN 61000-6-2, 6-4
Degree of protection	IP67
Approvals	CE

Power supply 7/8"

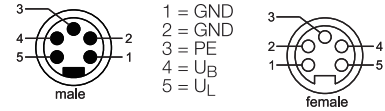

Analog output M12 x 1

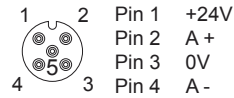

Analog output

Addr.	Byte0	Byte1	Byte2	Byte3	Byte4	Byte5	Byte6	Byte7
Ch.	C5(A0)	C6(A1)	C7(A2)	C8(A3)				

* "C5 (A0)" means that the 5 M12 interface in the I/O interface is A10.

Ordering data

GXPI-DIO8AO4-0009	GXEC-DIO8AO4-0009	GXEI-DIO8AO4-0009	GXDPI-DIO8AO4-0009







* Ethernet communication interface refer to P6 , PROFIBUS-DP/Device Netcommunication interface refer to P8.

Accessories

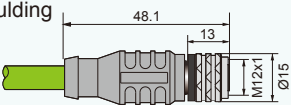
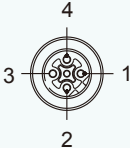
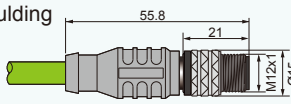
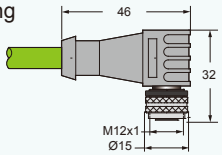

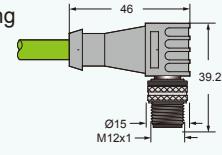
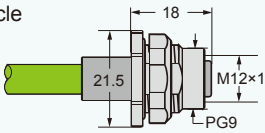
Connector (Ethernet/IP™, Modbus™, TCP)	Type NO.	ID NO.	Pinout	
M12 Pre-moulding Straight Female 	EIK4-2M/F41 EIK4-5M/F41 EIK4-10M/F41	10017210 10017211 10017212	<p>Female</p> <p>1.WH/OR(+tx) 2.WH/GN(+rx) 3.OR(-tx) 4.GN(-rx)</p>	
M12 Pre-moulding Straight Male 	EIZ4-2M/F41 EIZ4-5M/F41 EIZ4-10M/F41	10017215 10017216 10017217		
M12 Pre-moulding Right angle Female 	EILK4-2M/F41 EILK4-5M/F41 EILK4-10M/F41	10017220 10017221 10017222		
M12 Pre-moulding Right angle Male 	EILZ4-2M/F41 EILZ4-5M/F41 EILZ4-10M/F41	10017225 10017226 10017227		
M12 Receptacle Female 	FEIK41-2M/F41 FEIK41-5M/F41 FEIK41-10M/F41	10017395 10017396 10017397		
M12 Receptacle Male 	FEIZ41-2M/F41 FEIZ41-5M/F41 FEIZ41-10M/F41	10017400 10017401 10017402		
RJ45 straight 	RJ45S-2M/F41 RJ45S-5M/F41 RJ45S-10M/F41	10250040 10250041 10250042		<p>Standard</p> <p>1.WH/OR 2.OR 3.WH/GN 4.N/C 5.N/C 6.GN 7.N/C 8.N/C</p> <p>Cross</p> <p>1.WH/GN 2.GN 3.WH/OR 4.N/C 5.OR 6.N/C 7.N/C 8.N/C</p> <p>*Cross type: RJ45S-*M/F41-CR TRJ45S-*M/F41-CR BRJ45S-*M/F41-CR</p>
RJ45 right angle Buckle up 	TRJ45S-2M/F41 TRJ45S-5M/F41 TRJ45S-10M/F41	10250050 10250051 10250052		
RJ45 right angle Buckle down 	BRJ45S-2M/F41 BRJ45S-5M/F41 BRJ45S-10M/F41	10250060 10250061 10250062		

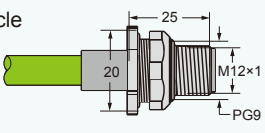
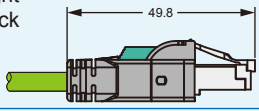

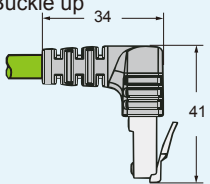
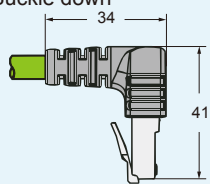
Connector(PROFINET)	Type NO.	ID NO.	Pinout
M12 Pre-moulding Straight Female 	EIK4-2M/F21 EIK4-5M/F21 EIK4-10M/F21	10017320 10017321 10017322	孔座 
M12 Pre-moulding Straight Male 	EIZ4-2M/F21 EIZ4-5M/F21 EIZ4-10M/F21	10017325 10017326 10017327	
M12 Pre-moulding Right angle Female 	EILK4-2M/F21 EILK4-5M/F21 EILK4-10M/F21	10017330 10017331 10017332	1.Yellow(+tx) 2.White(+rx) 3.Orange(-tx) 4.Blue(-rx) 针座 
M12 Pre-moulding Right angle Male 	EILZ4-2M/F21 EILZ4-5M/F21 EILZ4-10M/F21	10017335 10017336 10017337	
M12 Receptacle Female 	FEIK41-2M/F21 FEIK41-5M/F21 FEIK41-10M/F21	10017415 10017416 10017417	
M12 Receptacle Male 	FEIZ41-2M/F21 FEIZ41-5M/F21 FEIZ41-10M/F21	10017420 10017421 10017422	
RJ45 straight Quick Unlock 	SRJ45S-2M/F21 SRJ45S-5M/F21 SRJ45S-10M/F21	10250090 10250091 10250092	
RJ45 right angle Buckle up 	TRJ45-2M/F21 TRJ45-5M/F21 TRJ45-10M/F21	10250100 10250101 10250102	
RJ45 right angle Buckle down 	BRJ45-2M/F21 BRJ45-5M/F21 BRJ45-10M/F21	10250110 10250111 10250112	

Accessories



Connector(EtherCAT)	Type NO.	ID NO.	Pinout
<p>M12 Pre-moulding Straight Female</p>	<p>EIK4-2M/F230 EIK4-5M/F230 EIK4-10M/F230</p>	<p>10016265 10016266 10016267</p>	<p>Female</p>
<p>M12 Pre-moulding Straight Male</p>	<p>EIZ4-2M/F230 EIZ4-5M/F230 EIZ4-10M/F230</p>	<p>10016268 10016269 10016270</p>	
<p>M12 Pre-moulding Right angle Female</p>	<p>EILK4-2M/F230 EILK4-5M/F230 EILK4-10M/F230</p>	<p>10016271 10016284 10016273</p>	<p>1. Orange/White (+tx) 2. Blue/White (+rx) 3. Orange (-tx) 4. Blue (-rx)</p>
<p>M12 Pre-moulding Right angle Male</p>	<p>EILZ4-2M/F230 EILZ4-5M/F230 EILZ4-10M/F230</p>	<p>10016274 10016275 10016276</p>	<p>Male</p>
<p>M12 Receptacle Female</p>	<p>FEIK41-2M/F230 FEIK41-5M/F230 FEIK41-10M/F230</p>	<p>10041057 10041058 10041059</p>	
<p>M12 Receptacle Male</p>	<p>FEIZ41-2M/F230 FEIZ41-5M/F230 FEIZ41-10M/F230</p>	<p>10041060 10041037 10041038</p>	



Connector(EtherCAT)	Type NO.	ID NO.	Pinout
RJ45 straight 	RJ45S-2M/F230 RJ45S-5M/F230 RJ45S-10M/F230	10250374 10250375 10250376	 1.OR/WH 2.OR 3.BU/WH 4.N/C 5.N/C 6.BU 7.N/C 8.N/C
RJ45 right angle Buckle up 	TRJ45S-2M/F230 TRJ45S-5M/F230 TRJ45S-10M/F230	10250377 10250378 10250379	
RJ45 right angle Buckle down 	BRJ45S-2M/F230 BRJ45S-5M/F230 BRJ45S-10M/F230	10250380 10250381 10250382	

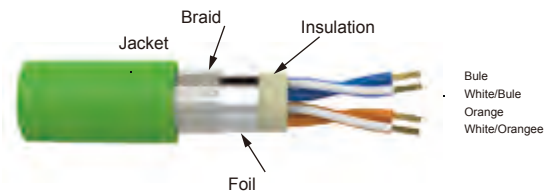

F230



Cable Type NO.	Authentication	Data parameter		Jacket	Shield	Suffix code
		Cable parameters	20 °C Conductor resistance/insulation	Material, Colour, Outer diameter		
CS042671-*M	UL/CSA DESINA CE	4*26AWG	140 Ω /km PO	PUR Yellow green 4.8mm	Foil/Braid	F230 80°C 30Volts

Accessories



Connector(EtherCAT)	Type NO.	ID NO.	Pinout
<p>M12 Pre-moulding Straight Female</p>	<p>EIK4-2M/F211 EIK4-5M/F211 EIK4-10M/F211</p>	<p>10016277 10016278 10016279</p>	<p>Female</p>
<p>M12 Pre-moulding Straight Male</p>	<p>EIZ4-2M/F211 EIZ4-5M/F211 EIZ4-10M/F211</p>	<p>10016280 10016281 10016282</p>	
<p>M12 Pre-moulding Right angle Female</p>	<p>EILK4-2M/F211 EILK4-5M/F211 EILK4-10M/F211</p>	<p>10016283 10016284 10016285</p>	<p>1.Yellow(+tx) 2.White(+rx) 3.Orange(-tx) 4.Blue(-rx)</p> <p>Male</p>
<p>M12 Pre-moulding Right angle Male</p>	<p>EILZ4-2M/F211 EILZ4-5M/F211 EILZ4-10M/F211</p>	<p>10016286 10016287 10016288</p>	
<p>M12 Receptacle Female</p>	<p>FEIK41-2M/F211 FEIK41-5M/F211 FEIK41-10M/F211</p>	<p>10041045 10041046 10041047</p>	
<p>M12 Receptacle Male</p>	<p>FEIZ41-2M/F211 FEIZ41-5M/F211 FEIZ41-10M/F211</p>	<p>10041048 10041049 10041050</p>	

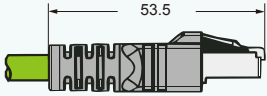

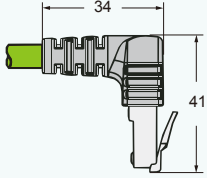
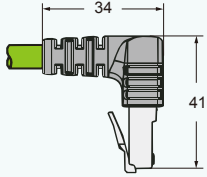
Connector(EtherCAT)	Type NO.	ID NO.	Pinout
RJ45 straight 	RJ45S-2M/F211 RJ45S-5M/F211 RJ45S-10M/F211	10250383 10250384 10250385	
RJ45 right angle Buckle up 	TRJ45S-2M/F211 TRJ45S-5M/F211 TRJ45S-10M/F211	10250386 10250387 10250388	
RJ45 right angle Buckle down 	BRJ45S-2M/F211 BRJ45S-5M/F211 BRJ45S-10M/F211	10250389 10250390 10250391	

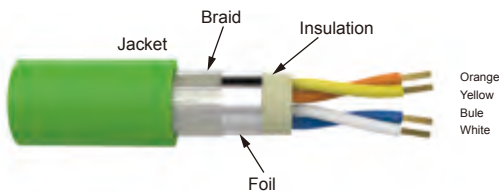





F211

Cable Type NO.	Authentication	Data parameter		Jacket	Shield	Suffix code
		Cable parameters	20 °CConductor resistance/insulation	Material, Colour 、 Outer diameter		
CS042461-*M	UL/CSA DESINA CE	4*24AWG	91 PO Ω /km	PVC Yellow green 5.4mm	Foil/Braid	F211 80°C 300 Volts

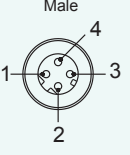
Accessories

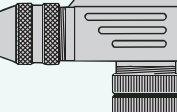
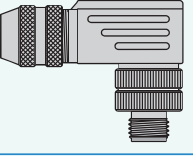







Field wirable connector(Ethernet)	Type NO.	ID NO.	Features	Pinout
M12 Straight Female 	EK4238-0/9	10091220	4A,250V,-40 ~ +85°C Match with 4-pin D-code M12 pre-moulding/ receptacle connector	
M12 Straight Male 	EZ4238-0/9	10091230		
M12 Right angle Female 	ELK4238-0/9	10091221		
M12 Right angle Male 	ELZ4238-0/9	10091231		
RJ45 Straight Metal Field wirable 	RJ45/HM	10250161		

Connector(Profibus-DP)	Features	Type NO.	ID NO.	Pinout
	M12 Pre-moulding Straight Female B-code, Braid	EPK5-2M EPK5-5M EPK5-10M	10012000 10012001 10012002	
	M12 Pre-moulding Right angle Female B-code, Braid	EPLK5-2M EPLK5-5M EPLK5-10M	10012010 10012011 10012012	
	M12 Pre-moulding Straight Male B-code, Braid	EPZ5-2M EPZ5-5M EPZ5-10M	10012020 10012021 10012022	
	M12 Pre-moulding Right angle Male B-code, Braid	EPLZ5-2M EPLZ5-5M EPLZ5-10M	10012030 10012031 10012032	
	M12 Pre-moulding Female/Male B-code, Braid	EPK5 EPZ5-2M EPK5 EPZ5-5M EPK5 EPZ5-10M	10012040 10012041 10012042	
	M12 Pre-moulding Female/Male B-code, Braid	EPLK5 EPLZ5-2M EPLK5 EPLZ5-5M EPLK5 EPLZ5-10M	10012070 10012071 10012072	
	4A, 250V, -40 ~ +85°C Match with 5-pin B-code M12 pre-moulding/ receptacle connector Female	EK5228-0/9	10091200	
	4A, 250V, -40 ~ +85°C Match with 5-pin B-code M12 pre-moulding/ receptacle connector Male	EZ5228-0/9	10091210	
	Profibus-DP Cable Two core Multi Strand Foil/Braid	CS022280-*M	58100251	
	Profibus-DP Splitter	EPK5-2EPZ5-V	10081001	
	Profibus-DP Termination resistors	EPZ5-TR	10085000	

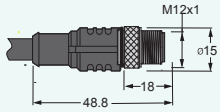

Connector(DeviceNet)	Features	Type NO.	ID NO.	Pinout
	M12 Pre-moulding Straight Female A-code, Thin Cable	ENK5-2M ENK5-5M ENK5-10M	10013000 10013001 10013002	
	M12 Pre-moulding Right angle Female A-code, Thin Cable	ENLK5-2M ENLK5-5M ENLK5-10M	10013010 10013011 10013012	
	M12 Pre-moulding Straight Male A-code, Thin Cable	ENZ5-2M ENZ5-5M ENZ5-10M	10013020 10013021 10013022	
	M12 Pre-moulding Right angle Male A-code, Thin Cable	ENLZ5-2M ENLZ5-5M ENLZ5-10M	10013030 10013031 10013032	
	M12 Pre-moulding Female/Male A-code, Thin Cable	ENK5 ENZ5-2M ENK5 ENZ5-5M ENK5 ENZ5-10M	10013040 10013041 10013042	
	M12 Pre-moulding Female/Male A-code, Thin Cable	ENLK5 ENLZ5-2M ENLK5 ENLZ5-5M ENLK5 ENLZ5-10M	10013070 10013071 10013072	
	DeviceNET T type	MNZ5-ENK5-MNK5	10082001	
	Terminating resistor M12x1 Male M12x1 Female	ENZ5-TR ENK5-TR	10085010 10085011	

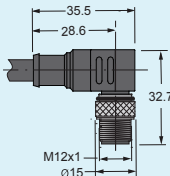
Connector(DeviceNet)	Features	Type NO.	ID NO.	Pinout
	7/8" Pre-moulding Straight Female Thick Cable	MNK5-2M MNK5-5M MNK5-10M	10031000 10031001 10031002	
	7/8" Pre-moulding Right angle Female Thick Cable	MNLK5-2M MNLK5-5M MNLK5-10M	10031010 10031011 10031012	
	7/8" Pre-moulding Straight Male Thick Cable	MNZ5-2M MNZ5-5M MNZ5-10M	10031020 10031021 10031022	
	7/8" Pre-moulding Right angle Male Thick Cable	MNLZ5-2M MNLZ5-5M MNLZ5-10M	10031030 10031031 10031032	
	7/8" Pre-moulding Female/Male Thick Cable	MNK5 MNZ5-2M MNK5 MNZ5-5M MNK5 MNZ5-10M	10031040 10031041 10031042	
	7/8" Pre-moulding Female/Male Thick Cable	MNLK5 MNLZ5-2M MNLK5 MNLZ5-5M MNLK5 MNLZ5-10M	10031070 10031071 10031072	
	Thick Cable Mid Cable Thin Cable	CS041580-*M CS041680-*M CS042280-*M	58200251 58210251 58220251	
	DeviceNET T type	MNZ5-2MNK5	10082000	
	Terminating resistor 7/8" Male 7/8" Female	MNZ5-TR MNK5-TR	10085020 10085021	

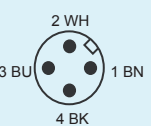
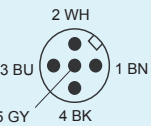
Connector(Power Supply)	Features	Type NO.	ID NO.	Pinout
	7/8"Pre-moulding Straight Female	MK5-2M MK5-5M MK5-10M	10033000 10033001 10033002	<ul style="list-style-type: none"> 1=BK (GND) 2=BU (GND) 3=GNYE (PE) 4=BN (U_s) 5=WH (U_x)
	7/8"Pre-moulding Right angle Female	MLK5-2M MLK5-5M MLK5-10M	10033010 10033011 10033012	<ul style="list-style-type: none"> 1=BK (GND) 2=BU (GND) 3=GNYE (PE) 4=BN (U_s) 5=WH (U_x)
	7/8"Pre-moulding Straight Male	MZ5-2M MZ5-5M MZ5-10M	10033020 10033021 10033022	<ul style="list-style-type: none"> 1=BK (GND) 2=BU (GND) 3=GNYE (PE) 4=BN (U_s) 5=WH (U_x)
	7/8"Pre-moulding Right angle Male	MLZ5-2M MLZ5-5M MLZ5-10M	10033030 10033031 10033032	<ul style="list-style-type: none"> 1=BK (GND) 2=BU (GND) 3=GNYE (PE) 4=BN (U_s) 5=WH (U_x)
	7/8"Pre-moulding Female/Male	MK5 MZ5-2M MK5 MZ5-5M MK5 MZ5-10M	10033040 10033041 10033042	<ul style="list-style-type: none"> 1=BK (GND) 2=BU (GND) 3=GNYE (PE) 4=BN (U_s) 5=WH (U_x)
	7/8"Pre-moulding Female/Male	MLK5 MLZ5-2M MLK5 MLZ5-5M MLK5 MLZ5-10M	10033070 10033071 10033072	<ul style="list-style-type: none"> 1=BK (GND) 2=BU (GND) 3=GNYE (PE) 4=BN (U_s) 5=WH (U_x)
	7/8" T type power connector 5pins	MZ5-2MK5	10084000	<ul style="list-style-type: none"> 1=BK (GND) 2=BU (GND) 3=GNYE (PE) 4=BN (U_s) 5=WH (U_x) <p>2x7/8"Female 1x7/8"Male</p>

Connector(I/O)	Features	Type NO.	ID NO.	Pinout
	M12 Pre-moulding Straight Female 3pins A-code	EZ3-2M/P00 EZ3-5M/P00 EZ3-10M/P00	10011060 10011061 10011062	
	M12 Pre-moulding Straight Female 4pins A-code	EZ4-2M/P00 EZ4-5M/P00 EZ4-10M/P00	10011070 10011071 10011072	
	M12 Pre-moulding Straight Female 5pins A-code	EZ5-2M/P00 EZ5-5M/P00 EZ5-10M/P00	10011510 10011511 10011512	
	M12 Pre-moulding Right angle Female 3pins A-code	ELZ3-2M/P00 ELZ3-5M/P00 ELZ3-10M/P00	10011090 10011091 10011092	
	M12 Pre-moulding Right angle Female 4pins A-code	ELZ4-2M/P00 ELZ4-5M/P00 ELZ4-10M/P00	10011100 10011101 10011102	
	M12 Pre-moulding Right angle Female 5pins A-code	ELZ5-2M/P00 ELZ5-5M/P00 ELZ5-10M/P00	10011530 10011531 10011532	

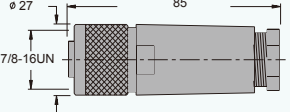
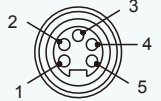
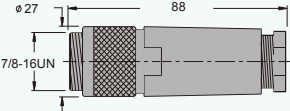
Connector(I/O)	Features	Type NO.	ID NO.	Pinout
	M12 Pre-moulding Female/Male 3pins A-code	EK3 EZ3-2M/P00 EK3 EZ3-5M/P00 EK3 EZ3-10M/P00	10011120 10011121 10011122	
	M12 Pre-moulding Female/Male 4pins A-code	EK4 EZ4-2M/P00 EK4 EZ4-5M/P00 EK4 EZ4-10M/P00	10011130 10011131 10011132	
	M12 Pre-moulding Female/Male 5pins A-code	EK5 EZ5-2M/P00 EK5 EZ5-5M/P00 EK5 EZ5-10M/P00	10011540 10011541 10011542	
	M12 Pre-moulding Female/Male 3pins A-code	ELK3 ELZ3-2M/P00 ELK3 ELZ3-5M/P00 ELK3 ELZ3-10M/P00	10011150 10011151 10011152	
	M12 Pre-moulding Female/Male 4pins A-code	ELK4 ELZ4-2M/P00 ELK4 ELZ4-5M/P00 ELK4 ELZ4-10M/P00	10011160 10011161 10011162	
	M12 Pre-moulding Female/Male 5pins A-code	ELK5 ELZ5-2M/P00 ELK5 ELZ5-5M/P00 ELK5 ELZ5-10M/P00	10011550 10011551 10011552	

5pins 7/8" Field wirable connector (power supply / DeviceNET)	Features	Type NO.	ID NO.	Pinout
	Nylon+Glass fiber/Black Cast aluminum coupling nuts PG11 cable gland Accepts 8-10 mm cable diameter Screw terminals 85°C,250V,9 A	MK5211-0/11	10092101	
	Nylon+Glass fiber/Black Cast aluminum coupling nuts PG13.5 cable gland Accepts 10-12 mm cable diameter Screw terminals 85°C,250V,9 A	MK5211-0/13.5	10092102	
	Nylon+Glass fiber/Black Cast aluminum coupling nuts PG11 cable gland Accepts 8-10 mm cable diameter Screw terminals 85°C,250V,9 A	MZ5211-0/11	10092121	
	Nylon+Glass fiber/Black Cast aluminum coupling nuts PG11 cable gland Accepts 10-12 mm cable diameter Screw terminals 85°C,250V,9 A	MZ5211-0/13.5	10092122	

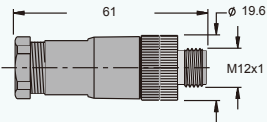
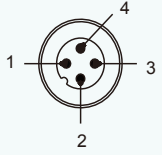
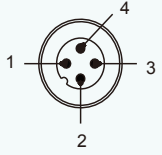
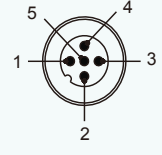
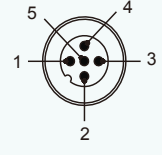
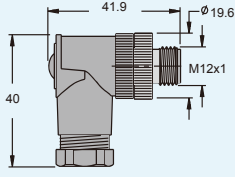
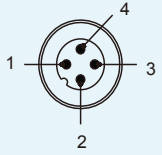
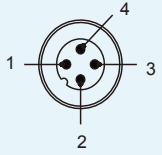
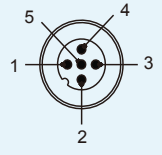
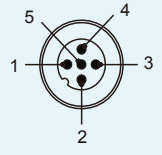
Field wireable connector	Features	Type NO.	ID NO.	Pinout
	PBT, Black, nickel plated brass coupling nut PG 7 cable gland Accepts 4-6 mm cable diameter Accepts 0.75 mm ² Max. Screw terminals 85°C, 250 V, 4 A	EZ4112-0/7	10091020	
	PBT, Black, nickel plated brass coupling nut PG 9 cable gland Accepts 6-8 mm cable diameter Accepts 0.75 mm ² Max. Screw terminals 85°C, 250 V, 4 A	EZ4112-0/9	10091021	
	PBT, Black, nickel plated brass coupling nut PG 7 cable gland Accepts 4-6 mm cable diameter Accepts 0.75 mm ² Max. Screw terminals 85°C, 125 V, 4 A	EZ5112-0/7	10091022	
	PBT, Black, nickel plated brass coupling nut PG 9 cable gland Accepts 6-8 mm cable diameter Accepts 0.75 mm ² Max. Screw terminals 85°C, 125 V, 4 A	EZ5112-0/9	10091023	
	PBT, Black, nickel plated brass coupling nut PG 7 cable gland Accepts 4-6 mm cable diameter Accepts 0.75 mm ² Max. Screw terminals 85°C, 250 V, 4 A	ELZ4112-0/7	10091030	
	PBT, Black, nickel plated brass coupling nut PG 9 cable gland Accepts 6-8 mm cable diameter Accepts 0.75 mm ² Max. Screw terminals 85°C, 250 V, 4 A	ELZ4112-0/9	10091031	
	PBT, Black, nickel plated brass coupling nut PG 7 cable gland Accepts 4-6 mm cable diameter Accepts 0.75 mm ² Max. Screw terminals 85°C, 125 V, 4 A	ELZ5112-0/7	10091032	
	PBT, Black, nickel plated brass coupling nut PG 9 cable gland Accepts 6-8 mm cable diameter Accepts 0.75 mm ² Max. Screw terminals 85°C, 125 V, 4 A	ELZ5112-0/9	10091033	

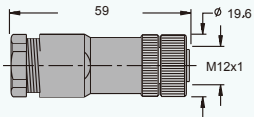
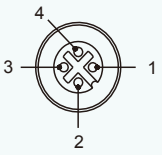
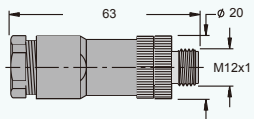
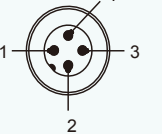
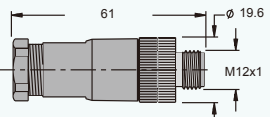
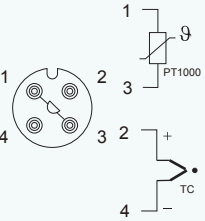
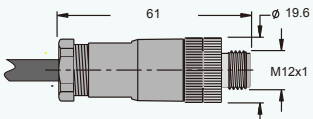
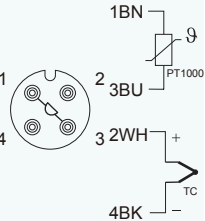
Field wireable connector	Features	Type NO.	ID NO.	Pinout
	<p>PBT, Black, nickel plated brass coupling nut Accepts 6-8 mm cable diameter Accepts 0.75 mm² Max. Screw terminals 85°C, 250 V, 4 A</p>	EK4112-1/11	10091101	
	<p>PBT, Black, nickel plated brass coupling nut Accepts 2*(3-5) mm cable diameter Accepts 0.75 mm² Max. Screw terminals 85°C, 250 V, 4 A</p>	EZ4112-1/11	10091111	
The cold junction point compensation	Features	Type NO.	ID NO.	Pinout
	<p>For BL67-2AI-TC, M12 x 1 round connector, field wireable, screw-terminal connection, integrated Pt1000 sensor for cold junction point compensation</p>	EZ4112-0/7-TH	10091800	
	<p>For BL67-2AI-TC, M12 x 1 round connector, field wireable, screw-terminal connection, integrated Pt1000 sensor for cold junction point compensation</p>	EZ4-TH-2M/P00 EZ4-TH-5M/P00 EZ4-TH-10M/P00	10113000 10113001 10113002	

Type NO.	ID NO.	Page number	Type NO.	ID NO.	Page number
BRJ45-10M/F21	10250112	027	EIZ4-5M/F41	10017216	026
BRJ45-2M/F21	10250110	027	EK3 EZ3-10M/P00	10011122	038
BRJ45-5M/F21	10250111	027	EK3 EZ3-2M/P00	10011120	038
BRJ45S-10M/F211	10250391	031	EK3 EZ3-5M/P00	10011121	038
BRJ45S-10M/F230	10250382	029	EK4 EZ4-10M/P00	10011132	038
BRJ45S-10M/F41	10250062	026	EK4 EZ4-2M/P00	10011130	038
BRJ45S-2M/F211	10250389	031	EK4 EZ4-5M/P00	10011131	038
BRJ45S-2M/F230	10250380	029	EK4112-1/11	10091101	041
BRJ45S-2M/F41	10250060	026	EK4238-0/9	10091220	032
BRJ45S-5M/F211	10250390	031	EK5 EZ5-10M/P00	10011542	038
BRJ45S-5M/F230	10250381	029	EK5 EZ5-2M/P00	10011540	038
BRJ45S-5M/F41	10250061	026	EK5 EZ5-5M/P00	10011541	038
CS022280-*M	58100251	033	EK5228-0/9	10091200	033
CS041580-*M	58200251	035	ELK3 ELZ3-10M/P00	10011152	038
CS041680-*M	58210251	035	ELK3 ELZ3-2M/P00	10011150	038
CS042280-*M	58220251	035	ELK3 ELZ3-5M/P00	10011151	038
EIK4-10M/F21	10017322	027	ELK4 ELZ4-10M/P00	10011162	038
EIK4-10M/F211	10016279	030	ELK4 ELZ4-2M/P00	10011160	038
EIK4-10M/F230	10016267	028	ELK4 ELZ4-5M/P00	10011161	038
EIK4-10M/F41	10017212	026	ELK4238-0/9	10091221	032
EIK4-2M/F21	10017320	027	ELK5 ELZ5-10M/P00	10011552	038
EIK4-2M/F211	10016277	030	ELK5 ELZ5-2M/P00	10011550	038
EIK4-2M/F230	10016265	028	ELK5 ELZ5-5M/P00	10011551	038
EIK4-2M/F41	10017210	026	ELZ3-10M/P00	10011092	037
EIK4-5M/F21	10017321	027	ELZ3-2M/P00	10011090	037
EIK4-5M/F211	10016278	030	ELZ3-5M/P00	10011091	037
EIK4-5M/F230	10016266	028	ELZ4-10M/P00	10011102	037
EIK4-5M/F41	10017211	026	ELZ4112-0/7	10091030	040
EILK4-10M/F21	10017332	027	ELZ4112-0/9	10091031	040
EILK4-10M/F211	10016285	030	ELZ4238-0/9	10091231	032
EILK4-10M/F230	10016273	028	ELZ4-2M/P00	10011100	037
EILK4-10M/F41	10017222	026	ELZ4-5M/P00	10011101	037
EILK4-2M/F21	10017330	027	ELZ5-10M/P00	10011532	037
EILK4-2M/F211	10016283	030	ELZ5112-0/7	10091032	040
EILK4-2M/F230	10016271	028	ELZ5112-0/9	10091033	040
EILK4-2M/F41	10017220	026	ELZ5-2M/P00	10011530	037
EILK4-5M/F21	10017331	027	ELZ5-5M/P00	10011531	037
EILK4-5M/F211	10016284	030	ENK5 ENZ5-10M	10013042	034
EILK4-5M/F230	10016284	028	ENK5 ENZ5-2M	10013040	034
EILK4-5M/F41	10017221	026	ENK5 ENZ5-5M	10013041	034
EILZ4-10M/F21	10017337	027	ENK5-10M	10013002	034
EILZ4-10M/F211	10016288	030	ENK5-2M	10013000	034
EILZ4-10M/F230	10016276	028	ENK5-5M	10013001	034
EILZ4-10M/F41	10017227	026	ENK5-TR	10085011	034
EILZ4-2M/F21	10017335	027	ENLK5 ENLZ5-10M	10013072	034
EILZ4-2M/F211	10016286	030	ENLK5 ENLZ5-2M	10013070	034
EILZ4-2M/F230	10016274	028	ENLK5 ENLZ5-5M	10013071	034
EILZ4-2M/F41	10017225	026	ENLK5-10M	10013012	034
EILZ4-5M/F21	10017336	027	ENLK5-2M	10013010	034
EILZ4-5M/F211	10016287	030	ENLK5-5M	10013011	034
EILZ4-5M/F230	10016275	028	ENLZ5-10M	10013032	034
EILZ4-5M/F41	10017226	026	ENLZ5-2M	10013030	034
EIZ4-10M/F21	10017327	027	ENLZ5-5M	10013031	034
EIZ4-10M/F211	10016282	030	ENZ5-10M	10013022	034
EIZ4-10M/F230	10016270	028	ENZ5-2M	10013020	034
EIZ4-10M/F41	10017217	026	ENZ5-5M	10013021	034
EIZ4-2M/F21	10017325	027	ENZ5-TR	10085010	034
EIZ4-2M/F211	10016280	030	EPK5 EPZ5-10M	10012042	033
EIZ4-2M/F230	10016268	028	EPK5 EPZ5-2M	10012040	033
EIZ4-2M/F41	10017215	026	EPK5 EPZ5-5M	10012041	033
EIZ4-5M/F21	10017326	027	EPK5-10M	10012002	033
EIZ4-5M/F211	10016281	030	EPK5-2EPZ5-V	10081001	033
EIZ4-5M/F230	10016269	028	EPK5-2M	10012000	033

Type NO.	ID NO.	Page number	Type NO.	ID NO.	Page number
EPK5-5M	10012001	033	GXDP-DI16	A2060001	012
EPLK5 EPLZ5-10M	10012072	033	GXDP-DI16-1000	A2060048	013
EPLK5 EPLZ5-2M	10012070	033	GXDP-DI8	A2060036	010
EPLK5 EPLZ5-5M	10012071	033	GXDP-DI8-1000	A2060040	011
EPLK5-10M	10012012	033	GXDP-DI8A14	A2060008	019
EPLK5-2M	10012010	033	GXDP-DI8A14-0090	A2060081	023
EPLK5-5M	10012011	033	GXDP-DI8A14-0010	A2060069	020
EPLZ5-10M	10012032	033	GXDP-DI8A14-0020	A2060073	021
EPLZ5-2M	10012030	033	GXDP-DI8A14-0030	A2060077	022
EPLZ5-5M	10012031	033	GXDP-DI8DO8	A2060002	017
EPZ5-10M	10012022	033	GXDP-DIO16	A2060062	018
EPZ5-2M	10012020	033	GXDP-DIO8AO4-0009	A2060088	024
EPZ5-5M	10012021	033	GXDP-DO16	A2060004	016
EPZ5-TR	10085000	033	GXDP-DO8	A2060003	014
EZ3-10M/P00	10011062	037	GXDP-DO8-0100	A2060006	015
EZ3-2M/P00	10011060	037	GXEC-DI16	A2060045	012
EZ3-5M/P00	10011061	037	GXEC-DI16-1000	A2060031	013
EZ4-10M/P00	10011072	037	GXEC-DI8	A2060037	010
EZ4112-0/7	10091020	040	GXEC-DI8-1000	A2060041	011
EZ4112-0/7-TH	10091800	041	GXEC-DI8A14	A2060066	019
EZ4112-0/9	10091021	040	GXEC-DI8A14-0090	A2060082	023
EZ4112-1/11	10091111	041	GXEC-DI8A14-0010	A2060070	020
EZ4238-0/9	10091230	032	GXEC-DI8A14-0020	A2060074	021
EZ4-2M/P00	10011070	037	GXEC-DI8A14-0030	A2060078	022
EZ4-5M/P00	10011071	037	GXEC-DI8DO8	A2060034	017
EZ4-TH-10M/P00	10113002	041	GXEC-DIO16	A2060063	018
EZ4-TH-2M/P00	10113000	041	GXEC-DIO8AO4-0009	A2060086	024
EZ4-TH-5M/P00	10113001	041	GXEC-DO16	A2060058	016
EZ5-10M/P00	10011512	037	GXEC-DO8	A2060051	014
EZ5112-0/7	10091022	040	GXEC-DO8-0100	A2060054	015
EZ5112-0/9	10091023	040	GXEI-DI16	A2060046	012
EZ5228-0/9	10091210	033	GXEI-DI16-1000	A2060029	013
EZ5-2M/P00	10011510	037	GXEI-DI8	A2060038	010
EZ5-5M/P00	10011511	037	GXEI-DI8-1000	A2060042	011
FEIK41-10M/F21	10017417	027	GXEI-DI8A14	A2060067	019
FEIK41-10M/F211	10041047	030	GXEI-DI8A14-0090	A2060083	023
FEIK41-10M/F230	10041059	028	GXEI-DI8A14-0010	A2060071	020
FEIK41-10M/F41	10017397	026	GXEI-DI8A14-0020	A2060075	021
FEIK41-2M/F21	10017415	027	GXEI-DI8A14-0030	A2060079	022
FEIK41-2M/F211	10041045	030	GXEI-DI8DO8	A2060032	017
FEIK41-2M/F230	10041057	028	GXEI-DIO16	A2060064	018
FEIK41-2M/F41	10017395	026	GXEI-DIO8AO4-0009	A2060087	024
FEIK41-5M/F21	10017416	027	GXEI-DO16	A2060059	016
FEIK41-5M/F211	10041046	030	GXEI-DO8	A2060052	014
FEIK41-5M/F230	10041058	028	GXEI-DO8-0100	A2060055	015
FEIK41-5M/F41	10017396	026	GXEN-DI16	A2060047	012
FEIZ41-10M/F21	10017422	027	GXEN-DI16-1000	A2060030	013
FEIZ41-10M/F211	10041050	030	GXEN-DI8	A2060039	010
FEIZ41-10M/F230	10041038	028	GXEN-DI8-1000	A2060043	011
FEIZ41-10M/F41	10017402	026	GXEN-DI8DO8	A2060061	017
FEIZ41-2M/F21	10017420	027	GXEN-DIO16	A2060065	018
FEIZ41-2M/F211	10041048	030	GXEN-DO16	A2060060	016
FEIZ41-2M/F230	10041060	028	GXEN-DO8	A2060053	014
FEIZ41-2M/F41	10017400	026	GXEN-DO8-0100	A2060056	015
FEIZ41-5M/F21	10017421	027	GXPI-DI16	A2060016	012
FEIZ41-5M/F211	10041049	030	GXPI-DI16-1000	A2060049	013
FEIZ41-5M/F230	10041037	028	GXPI-DI8	A2060020	010
FEIZ41-5M/F41	10017401	026	GXPI-DI8-1000	A2060044	011
GXDN-DI16	A2060021	012	GXPI-DI8A14	A2060068	019
GXDN-DI8	A2060035	010	GXPI-DI8A14-0090	A2060084	023
GXDN-DI8DO8	A2060011	017	GXPI-DI8A14-0010	A2060072	020
GXDN-DO16	A2060019	016	GXPI-DI8A14-0020	A2060076	021
GXDN-DO8	A2060050	014	GXPI-DI8A14-0030	A2060080	022

Type NO.	ID NO.	Page number	Type NO.	ID NO.	Page number
GXPI-DI8DO8	A2060022	017	SRJ45S-10M/F21	10250092	027
GXPI-DIO16	A2060025	018	SRJ45S-2M/F21	10250090	027
GXPI-DIO8AO4-0009	A2060085	024	SRJ45S-5M/F21	10250091	027
GXPI-DO16	A2060023	016	TRJ45-10M/F21	10250102	027
GXPI-DO8	A2060017	014	TRJ45-2M/F21	10250100	027
GXPI-DO8-0100	A2060057	015	TRJ45-5M/F21	10250101	027
MK5 MZ5-10M	10033042	036	TRJ45S-10M/F211	10250388	031
MK5 MZ5-2M	10033040	036	TRJ45S-10M/F230	10250379	029
MK5 MZ5-5M	10033041	036	TRJ45S-10M/F41	10250052	026
MK5-10M	10033002	036	TRJ45S-2M/F211	10250386	031
MK5211-0/11	10092101	039	TRJ45S-2M/F230	10250377	029
MK5211-0/13.5	10092102	039	TRJ45S-2M/F41	10250050	026
MK5-2M	10033000	036	TRJ45S-5M/F211	10250387	031
MK5-5M	10033001	036	TRJ45S-5M/F230	10250378	029
MLK5 MLZ5-10M	10033072	036	TRJ45S-5M/F41	10250051	026
MLK5 MLZ5-2M	10033070	036			
MLK5 MLZ5-5M	10033071	036			
MLK5-10M	10033012	036			
MLK5-2M	10033010	036			
MLK5-5M	10033011	036			
MLZ5-10M	10033032	036			
MLZ5-2M	10033030	036			
MLZ5-5M	10033031	036			
MNK5 MNZ5-10M	10031042	035			
MNK5 MNZ5-2M	10031040	035			
MNK5 MNZ5-5M	10031041	035			
MNK5-10M	10031002	035			
MNK5-2M	10031000	035			
MNK5-5M	10031001	035			
MNK5-TR	10085021	035			
MNLK5 MNLZ5-10M	10031072	035			
MNLK5 MNLZ5-2M	10031070	035			
MNLK5 MNLZ5-5M	10031071	035			
MNLK5-10M	10031012	035			
MNLK5-2M	10031010	035			
MNLK5-5M	10031011	035			
MNLZ5-10M	10031032	035			
MNLZ5-2M	10031030	035			
MNLZ5-5M	10031031	035			
MNZ5-10M	10031022	035			
MNZ5-2M	10031020	035			
MNZ5-2MKNK5	10082000	035			
MNZ5-5M	10031021	035			
MNZ5-ENK5-MNK5	10082001	034			
MNZ5-TR	10085020	035			
MZ5-10M	10033022	036			
MZ5211-0/11	10092121	039			
MZ5211-0/13.5	10092122	039			
MZ5-2M	10033020	036			
MZ5-2MK5	10084000	036			
MZ5-5M	10033021	036			
RJ45/HM	10091299	032			
RJ45S-10M/F211	10250385	031			
RJ45S-10M/F230	10250376	029			
RJ45S-10M/F41	10250042	026			
RJ45S-2M/F211	10250383	031			
RJ45S-2M/F230	10250374	029			
RJ45S-2M/F41	10250040	026			
RJ45S-5M/F211	10250384	031			
RJ45S-5M/F230	10250375	029			
RJ45S-5M/F41	10250041	026			
SRJ45S-10M/F21	10250092	031			
SRJ45S-2M/F21	10250090	029			

GSEE TECH

GX series fieldbus module



- Tianjin Geneuo Technology Co., Ltd.
- Address: Technology Avenue South Jinghai Economic Area, Tianjin, China
- Tel : +86-22-68277298
- Fax : +86-22-68277161
- Zipcode : 301609
- Web : www.gsee-tech.cn
www.gsee-tech.com
- E-mail : marketing_gsee@outlook.com



Geneuo Weibo



Geneuo Wechat