



User Guide

CS710 Series AC Drive Specialized for Cranes



Preface

Thank you for purchasing Inovance's CS710 series AC drive for cranes.

This product is a new-generation AC drive designed for cranes by Inovance. Compared with earlier AC drives, this product provides higher performance and more functions. It performs vector control to control the asynchronous motor efficiently. The CS710 series is used to drive and control the asynchronous motor for operations performed by a crane, such as hoisting, travel, and rotation.

This user guide describes how to use the CS710 crane AC drive properly. Read this guide before installing, running, maintaining, or checking the AC drive. In addition, use this product only after understanding the safety precautions for it.

NOTE

- ◆ For illustration purpose, the drawings in this user guide are sometimes shown without covers or protective guards. Remember to install the covers or protective guards as specified before using the product, and perform operations in accordance with the instructions.
- ◆ The drawings in the user guide are for illustration only. Actual products may vary.
- ◆ The instructions are subject to change, without notice, due to product upgrade, specification modification as well as efforts to increase the accuracy and convenience of the guide.
- ◆ Contact our agents or customer service center if you need a new user guide or have problems during the use.

Revision History

Date	Version	Change Description
May 2015	V0.0	First release.
May 2018	A01	<ul style="list-style-type: none"> ◆ Standardized the guide chapters. ◆ Added data of 0.4 to 15 kW models,
November 2018	A02	Updated Inovance's logo.
September 2019	A03	<ul style="list-style-type: none"> ◆ Added data of the CS700IO1 extension card. ◆ Deleted data of the CS700RC1 extension card and added data of the CS700RC2 extension card instead. ◆ Added "8.3.5 Replacing the Surge Protection Device". ◆ Updated "7.6 Fault Symptoms and Solutions".
July 2020	A04	Deleted the service hotline.
December 2020	A05	<ul style="list-style-type: none"> ◆ Added data of the MD500-PN1 communication card. ◆ Updated "3.2.1 Standard Wiring Diagram". ◆ Updated Figure 5-5 in "5.8 Frequency Reference Selection". ◆ Updated description of A0.07 in "6.1 Level-1 Menu (Group A) Parameter Table". ◆ Updated description of A0.07 in "6.2 Level-2 Menu (Group b, Group E*, Group U) Parameter Table". ◆ Updated "7.6 Fault Symptoms and Solutions". ◆ Updated the mounting hole data of 200 to 450 kW models.

Contents

Preface	1
Revision History	2
Safety Instructions	7
1 Product Information	13
1.1 Nameplate and Model Number	13
1.2 Components	14
2 System Connection	19
2.1 Connection Diagram	19
2.2 Description of Peripheral Electrical Devices	20
3 Installation and Wiring	22
3.1 Installation	22
3.1.1 Installation Environment	22
3.1.2 Mounting Clearance and Orientation	23
3.1.3 Installation Instructions	25
3.1.4 Mounting in a Cabinet	28
3.1.5 Removing and Installing the Cover	38
3.2 Wiring	41
3.2.1 Standard Wiring Diagram	41
3.2.2 Main Circuit Terminals	42
3.2.3 Layout and Dimensions of Main Circuit Terminals	49
3.2.4 Requirements on Main Circuit Wiring Tools	59
3.2.5 Control Board	61
3.2.6 Control Circuit Terminal Wiring	65
3.2.7 Wire Size and Torque Specifications of the Control Circuit	71
3.2.8 Wiring of the External Operating Panel	71
3.2.9 Wiring Checklist	72
4 Panel Operations	74
4.1 Introduction	74
4.2 LED Operating Panel	74
4.2.1 Function Indicators	74
4.2.2 LED Display	76
4.2.3 Keys on the LED Operating Panel	76
4.3 Viewing and Modifying Parameters	77
4.4 Parameter Structure	78
4.5 Viewing Status Parameters	78
5 System Commissioning	79

5.1 Quick Commissioning Guide	79
5.2 Precautions Before Power-on.....	80
5.3 Status Display After Power-on	80
5.4 Restoring Factory Settings.....	80
5.5 Motor Control Modes.....	81
5.6 Start and Stop Commands.....	81
5.6.1 Operating Panel Control.....	82
5.6.2 Terminal Control (DI).....	82
5.6.3 Serial Communication Control.....	83
5.7 Start and Stop Settings	83
5.7.1 Start Mode.....	83
5.7.2 Stop Mode	83
5.8 Frequency Reference Selection	84
5.8.1 Setting the Multi-reference Mode	84
5.8.2 Using Analog Input to Set Frequency Reference	85
5.9 Description of Terminals.....	85
5.9.1 DI Terminals	85
5.9.2 AI Terminals.....	86
5.9.3 DO Terminals.....	86
5.9.4 AO Terminals.....	86
5.9.5 PG Terminals	87
5.10 Auto-tuning	87
5.10.1 Motor Parameter Settings	87
5.10.2 Motor Parameter Auto-tuning.....	87
5.11 Password Setting.....	89
5.12 Application Examples.....	89
5.12.1 Hoisting System Braking.....	89
5.12.2 Safety Limit and Stop upon Faults	90
6 Parameter Table.....	91
6.1 Level-1 Menu (Group A) Parameter Table	91
6.2 Level-2 Menu (Group b, Group E*, Group U) Parameter Table	94
6.3 Level-3 Menu (Group F) Parameter Table	137
7 Troubleshooting.....	145
7.1 Safety Information.....	145
7.2 Troubleshooting During Trial Run	145
7.3 Fault Display	147
7.4 Reset upon Fault.....	149
7.5 Error Codes and Solutions.....	151
7.6 Fault Symptoms and Solutions	156

7.7 Error Sub-codes	158
8 Maintenance and Inspection	161
8.1 Routine Maintenance	161
8.2 Periodic Inspection.....	163
8.2.1 Periodic Inspection Items	163
8.2.2 Main Circuit Insulation Test.....	163
8.3 Part Replacement.....	164
8.3.1 Service Life of Quick-wear Parts	164
8.3.2 Number of Fans on the AC Drive.....	164
8.3.3 Replacement of Fans	165
8.3.4 DC Bus Electrolytic Capacitors.....	169
8.3.5 Replacement of the Surge Protection Board	169
8.4 Storage	169
9 Technical Data and Model Selection	170
9.1 Technical Data	170
9.2 Installation Dimensions	176
9.2.1 Dimensions of 0.4–160 kW AC Drive Models	176
9.2.2 Dimensions of 0.4–160 kW AC Drive Models with Mounting Bracket.....	178
9.2.3 Dimensions of 200–450 kW AC Drive Models	187
9.2.4 Dimensions of 200–450 kW AC Drive Models with Reactor Base.....	188
9.2.5 Mounting Bracket Dimensions.....	189
9.3 Options.....	191
9.4 Selection of Peripheral Electrical Devices	193
9.4.1 List of Peripheral Electrical Devices.....	193
9.4.2 Lug Models and Dimensions.....	194
9.4.3 Residual Current Device Selection	197
9.5 Selection of Braking Components	199
9.5.1 Selection of Braking Units.....	199
9.5.2 Selection of Braking Resistors	200
9.5.3 List of Braking Components.....	200
9.5.4 External and Installation Dimensions of Braking Units.....	202
9.6 Mounting Dimensions of External Operating Panels	202
10 Options	204
10.1 Extension I/O Cards	204
10.1.1 Multi-functional Extension I/O Card (MD38IO1)	204
10.1.2 Mini I/O Extension Card (MD38IO2)	207
10.1.3 Terminal Arrangement and Functions of MD38IO3.....	208
10.1.4 Multi-functional Extension I/O Card (CS700IO1)	209
10.1.5 Multi-functional Extension I/O Card (CS700RC2).....	211

10.2 Communication Extension Cards	213
10.2.1 CANopen Extension Card (MD38CAN2)	213
10.2.2 RS-485 Extension Card (MD38TX1)	217
10.2.3 PROFIBUS-DP Extension Card (MD38DP2)	218
10.2.4 PROFINET Communication Extension Card (MD500-PN1)	221
10.2.5 PZD Process Data Description and Parameter Address Definition	223
10.3 Encoder Extension Cards	227
10.3.1 Specifications of Encoder Extension Cards	227
10.3.2 Multi-functional PG Card (MD38PGMD)	228
10.3.3 Resolver PG Card (MD38PG4)	231
10.3.4 Shield Grounding for a PG Card	232
10.3.5 EMC Guidance	233
Appendix A Modbus Communication Protocol	234
A.1 Data Rules	234
A.2 Data Address Definition	238
Appendix B EMC Compliance	240
B.1 Definition of Terms	240
B.2 EMC Standards	240
B.2.1 EMC Standards	240
B.2.2 EMC Requirements for the Installation Environment	240
B.3 Selection of Peripheral EMC Devices	241
B.3.1 EMC Input Filter Installation on Power Input Side	241
B.3.2 AC Input Reactor Installation on the Power Input Side	242
B.3.3 AC Output Reactor Installation on Output Side	243
B.4 Shielded Cables	245
B.4.1 Requirements for Shielded Cables	245
B.4.2 Cabling Requirements	246
B.5 Leakage Current Requirements	247
B.6 Solutions to EMC Interference	248
Warranty Agreement	249

Safety Instructions

Safety Precautions

- 1) Before installing, using, and maintaining this equipment, read the safety information and precautions thoroughly, and comply with them during operations.
- 2) To ensure the safety of humans and equipment, follow the signs on the equipment and all the safety instructions in this user guide.
- 3) "CAUTION", "WARNING", and "DANGER" items in the guide do not indicate all safety precautions that need to be followed; instead, they just supplement the safety precautions.
- 4) Use this equipment according to the designated environment requirements. Damage caused by improper usage is not covered by warranty.
- 5) Inovance shall take no responsibility for any personal injuries or property damage caused by improper usage.

Safety Levels and Definitions



DANGER

Indicates that failure to comply with the notice will result in severe personal injuries or even death.



WARNING

Indicates that failure to comply with the notice will result in severe personal injuries or even death.



CAUTION

Indicates that failure to comply with the notice may result in minor or moderate personal injuries or equipment damage.

Safety Instructions

Unpacking



CAUTION

- ◆ Check whether the packing is intact and whether there is damage, water seepage, damp, and deformation.
- ◆ Unpack the package by following the package sequence. Do not hit the package with force.
- ◆ Check whether there are damage, rust, or injuries on the surface of the equipment or equipment accessories.
- ◆ Check whether the number of packing materials is consistent with the packing list.

 WARNING

- ◆ Do not install the equipment if you find damage, rust, or indications of use on the equipment or accessories.
- ◆ Do not install the equipment if you find water seepage, component missing or damage upon unpacking.
- ◆ Do not install the equipment if you find the packing list does not conform to the equipment you received.

Storage and Transportation

 CAUTION

- ◆ Store and transport this equipment based on the storage and transportation requirements for humidity and temperature.
- ◆ Avoid transporting the equipment in environments such as water splashing, rain, direct sunlight, strong electric field, strong magnetic field, and strong vibration.
- ◆ Avoid storing this equipment for more than three months. Long-term storage requires stricter protection and necessary inspections.
- ◆ Pack the equipment strictly before transportation. Use a sealed box for long-distance transportation.
- ◆ Never transport this equipment with other equipment or materials that may harm or have negative impacts on this equipment.

 WARNING

- ◆ Use professional loading and unloading equipment to carry large-scale or heavy equipment.
- ◆ When carrying this equipment with bare hands, hold the equipment casing firmly with care to prevent parts falling. Failure to comply may result in personal injuries.
- ◆ Handle the equipment with care during transportation and mind your step to prevent personal injuries or equipment damage.
- ◆ Never stand or stay below the equipment when the equipment is lifted by hoisting equipment.

Installation

 WARNING

- ◆ Thoroughly read the safety instructions and user guide before installation.
- ◆ Do not modify this equipment.
- ◆ Do not loosen fixing bolts (especially those marked in red) on equipment components.
- ◆ Do not install this equipment in places with strong electric or magnetic fields.
- ◆ When this equipment is installed in a cabinet or final equipment, protection measures such as a fireproof enclosure, electrical enclosure, or mechanical enclosure must be provided. The IP rating must meet IEC standards and local laws and regulations.

**DANGER**

- ◆ Equipment installation, wiring, maintenance, inspection, or parts replacement must be performed by only professionals.
- ◆ Installation, wiring, maintenance, inspection, or parts replacement must be performed by only experienced personnel who have been trained with necessary electrical information.
- ◆ Installation personnel must be familiar with equipment installation requirements and relevant technical materials.
- ◆ Before installing equipment with strong electromagnetic interference, such as a transformer, install an electromagnetic shielding device for this equipment to prevent malfunctions.

Wiring

**DANGER**

- ◆ Equipment installation, wiring, maintenance, inspection, or parts replacement must be performed by only professionals.
- ◆ Never perform wiring at power-on. Failure to comply will result in an electric shock.
- ◆ Before wiring, cut off all equipment power supplies. Wait at least 10 minutes before further operations because residual voltage exists after power-off.
- ◆ Make sure that the equipment is well grounded. Failure to comply will result in an electric shock.
- ◆ During wiring, follow the proper electrostatic discharge (ESD) procedures, and wear an antistatic wrist strap. Failure to comply will result in damage to internal equipment circuits.

**WARNING**

- ◆ Never connect the power cable to output terminals of the equipment. Failure to comply may cause equipment damage or even a fire.
- ◆ When connecting a drive with the motor, make sure that the phase sequences of the drive and motor terminals are consistent to prevent reverse motor rotation.
- ◆ Wiring cables must meet diameter and shielding requirements. The shielding layer of the shielded cable must be reliably grounded at one end.
- ◆ After wiring, make sure that no screws are fallen and cables are exposed in the equipment.

Power-on



- ◆ Before power-on, make sure that the equipment is installed properly with reliable wiring and the motor can be restarted.
- ◆ Before power-on, make sure that the power supply meets equipment requirements to prevent equipment damage or even a fire.
- ◆ At power-on, unexpected operations may be triggered on the equipment. Therefore, stay away from the equipment.
- ◆ After power-on, do not open the cabinet door and protective cover of the equipment. Failure to comply will result in an electric shock.
- ◆ Do not touch any wiring terminals at power-on. Failure to comply will result in an electric shock.
- ◆ Do not remove any part of the equipment at power-on. Failure to comply will result in an electric shock.

Operation



- ◆ Do not touch any wiring terminals during operation. Failure to comply will result in an electric shock.
- ◆ Do not remove any part of the equipment during operation. Failure to comply will result in an electric shock.
- ◆ Do not touch the equipment shell, fan, or resistor for temperature detection. Failure to comply will result in heat injuries.
- ◆ Signal detection must be performed by only professionals during operation. Failure to comply will result in personal injuries or equipment damage.



- ◆ Prevent metal or other objects from falling into the device during operation. Failure to comply may result in equipment damage.
- ◆ Do not start or stop the equipment using the contactor. Failure to comply may result in equipment damage.

Maintenance



- ◆ Equipment installation, wiring, maintenance, inspection, or parts replacement must be performed by only professionals.
- ◆ Do not maintain the equipment at power-on. Failure to comply will result in an electric shock.
- ◆ Before maintenance, cut off all equipment power supplies and wait at least 10 minutes.

 WARNING

- ◆ Perform daily and periodic inspection and maintenance for the equipment according to maintenance requirements and keep a maintenance record.

Repair

 DANGER

- ◆ Equipment installation, wiring, maintenance, inspection, or parts replacement must be performed by only professionals.
- ◆ Do not repair the equipment at power-on. Failure to comply will result in an electric shock.
- ◆ Before inspection and repair, cut off all equipment power supplies and wait at least 10 minutes.

 WARNING

- ◆ Require for repair services according to the product warranty agreement.
- ◆ When the equipment is faulty or damaged, require professionals to perform troubleshooting and repair by following repair instructions and keep a repair record.
- ◆ Replace quick-wear parts of the equipment according to the replacement guide.
- ◆ Do not operate damaged equipment. Failure to comply may result in worse damage.
- ◆ After the equipment is replaced, perform wiring inspection and parameter settings again.

Disposal

 WARNING

- ◆ Dispose of retired equipment by following local regulations or standards. Failure to comply may result in property damage, personal injuries, or even death.
- ◆ Recycle retired equipment by following industry waste disposal standards to avoid environmental pollution.

Safety Signs

■ Description of safety signs in the user guide



Read the user guide before installation and operation.



Reliably ground the system and equipment.



Danger!



High temperature!



Prevent personal injuries caused by machines.



High voltage!



Wait xx minutes before further operations.

■ Description of safety signs on the equipment

For safe equipment operation and maintenance, comply with safety signs on the equipment, and do not damage or remove the safety labels. The following table describes the safety signs.

Safety Sign	Description
	<ul style="list-style-type: none"> ◆ Read the user guide before installation and operation. Failure to comply will result in an electric shock. ◆ Do not remove the cover at power-on or within 10 minutes after power-off. ◆ Before maintenance, inspection, and wiring, cut off input and output power, and wait at least 10 minutes until the power indicator is off.

1 Product Information

1.1 Nameplate and Model Number

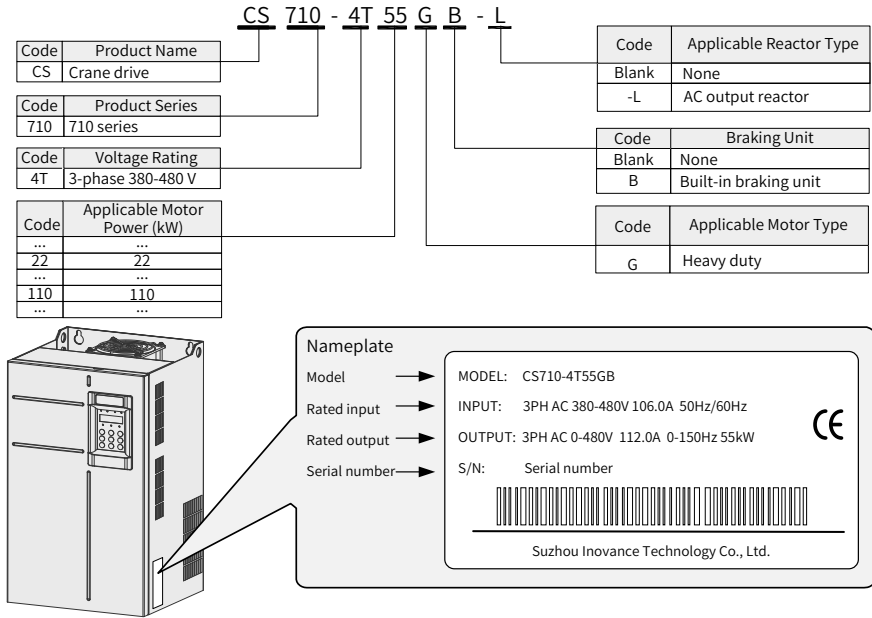
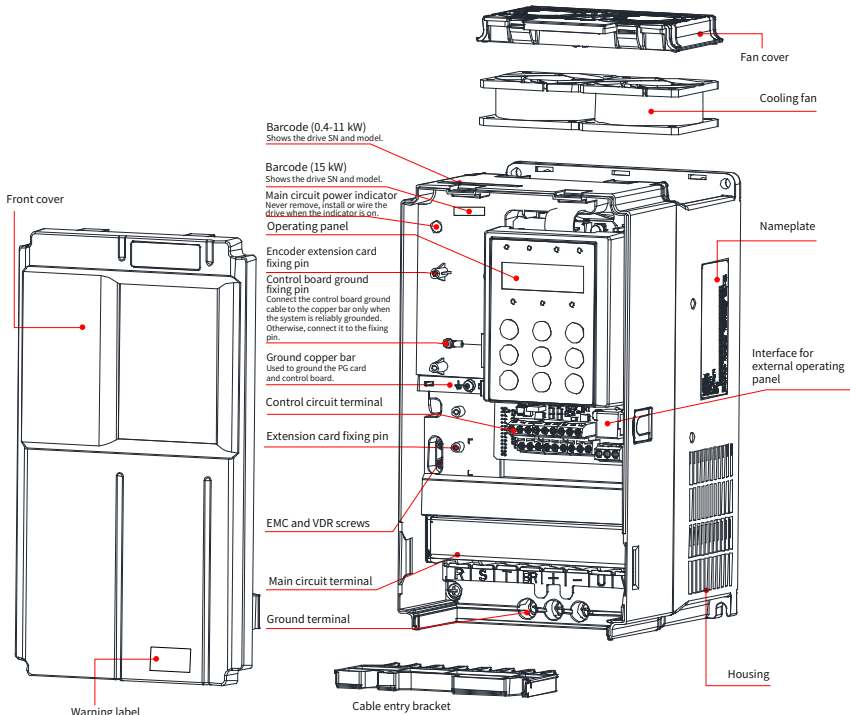

Figure 1-1 Nameplate and model number

1.2 Components

Depending on the voltage and power rating, the CS710 series AC drive has either a plastic housing or a sheet metal housing, as shown in the following figures.







Warning label	Description
 	Caution! Read the user guide before installing and running the drive.
 	Danger! Do not remove the front cover while power is on or within 10 minutes after power-off.

Figure 1-2 Components (three-phase 380–480 V, 0.4–15 kW)





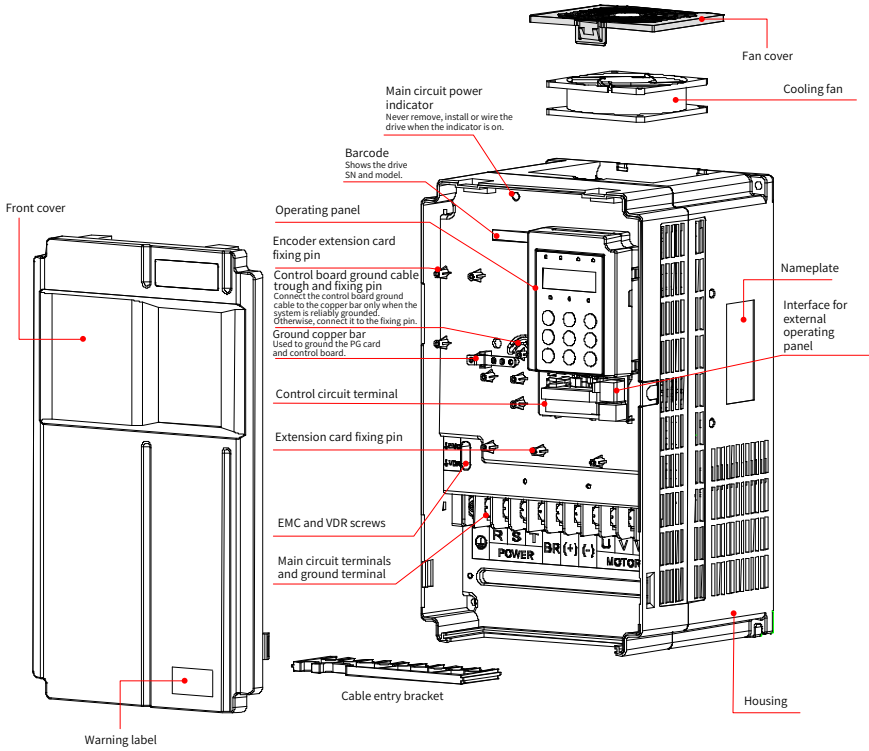

Warning label	Description
 	Caution! Read the user guide before installing and running the drive.
 	Danger! Do not remove the front cover while power is on or within 10 minutes after power-off.

Figure 1-3 Components (three-phase 380–480 V, 18.5–37 kW)





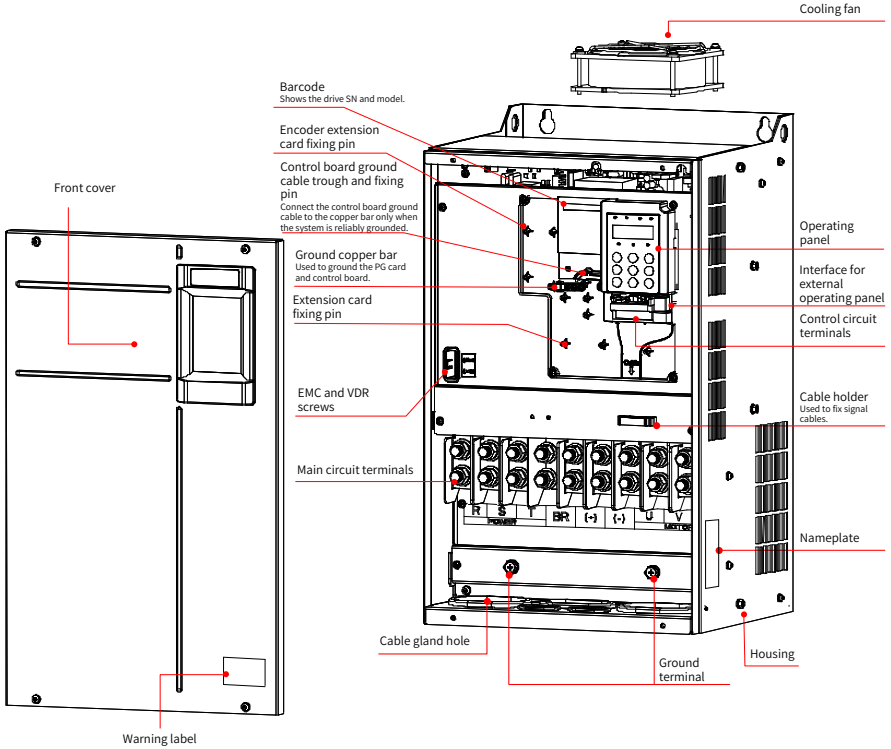

Warning label	Description
 	Caution! Read the user guide before installing and running the drive.
 	Danger! Do not remove the front cover while power is on or within 10 minutes after power-off.

Figure 1-4 Components (three-phase 380–480 V, 45–160 kW)

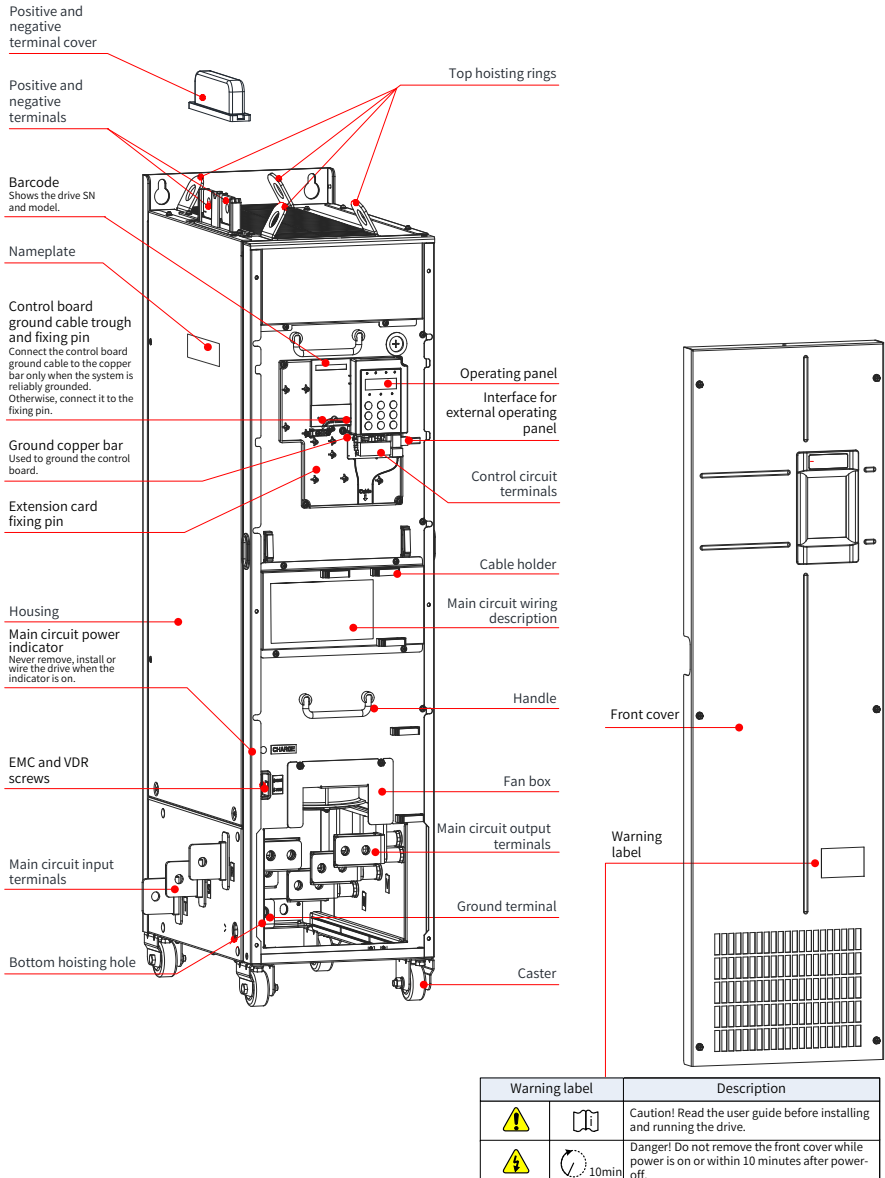

Figure 1-5 Components (three-phase 380–480 V, 200–450 kW)

1 Product Information

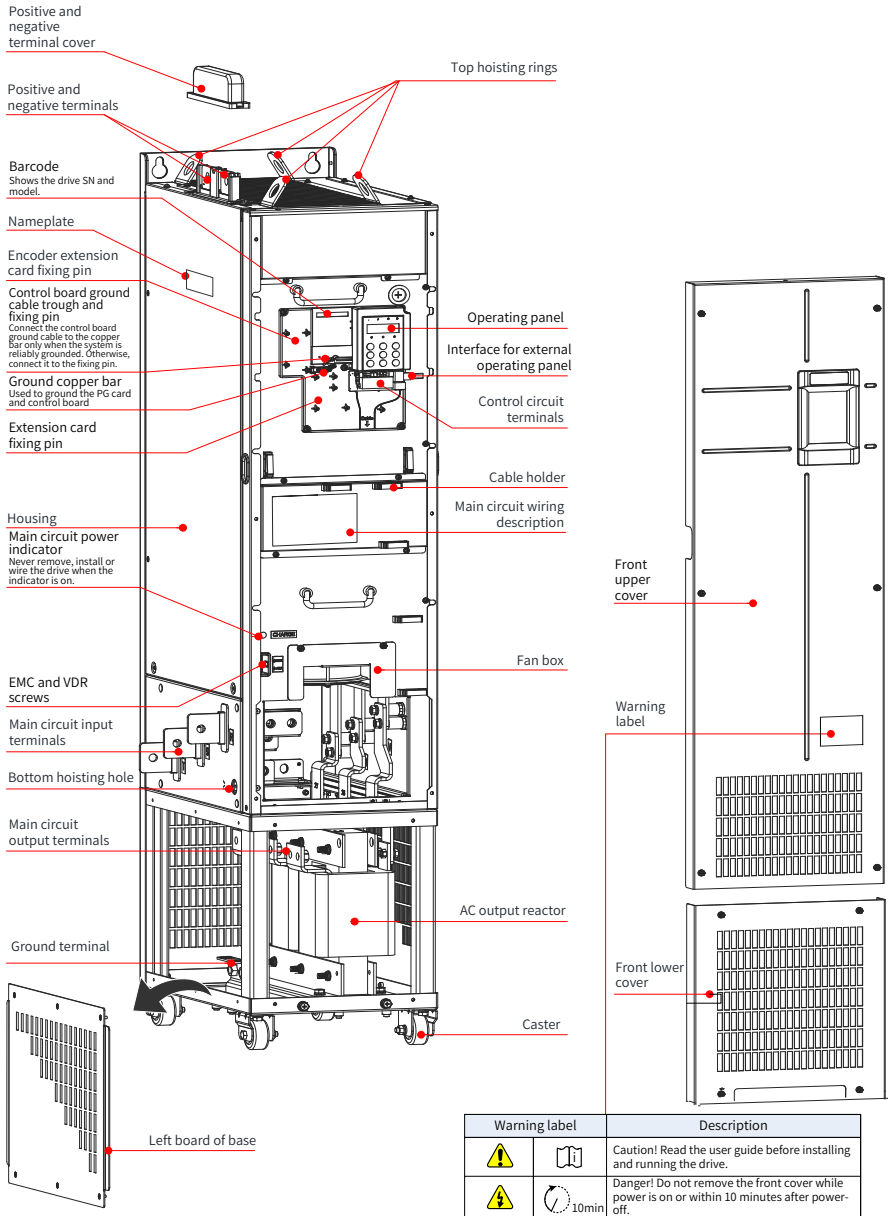

Figure 1-6 Components (three-phase 380–480 V, 200–450 kW-L)

2 System Connection

2.1 Connection Diagram

To use the CS710 series AC drive to control an asynchronous motor, install a variety of electrical devices on both input and output sides to ensure system safety and stability. The following figure shows the system connection of a CS710 series AC drive with three-phase 380 to 480 V/18.5 kW or higher rating.

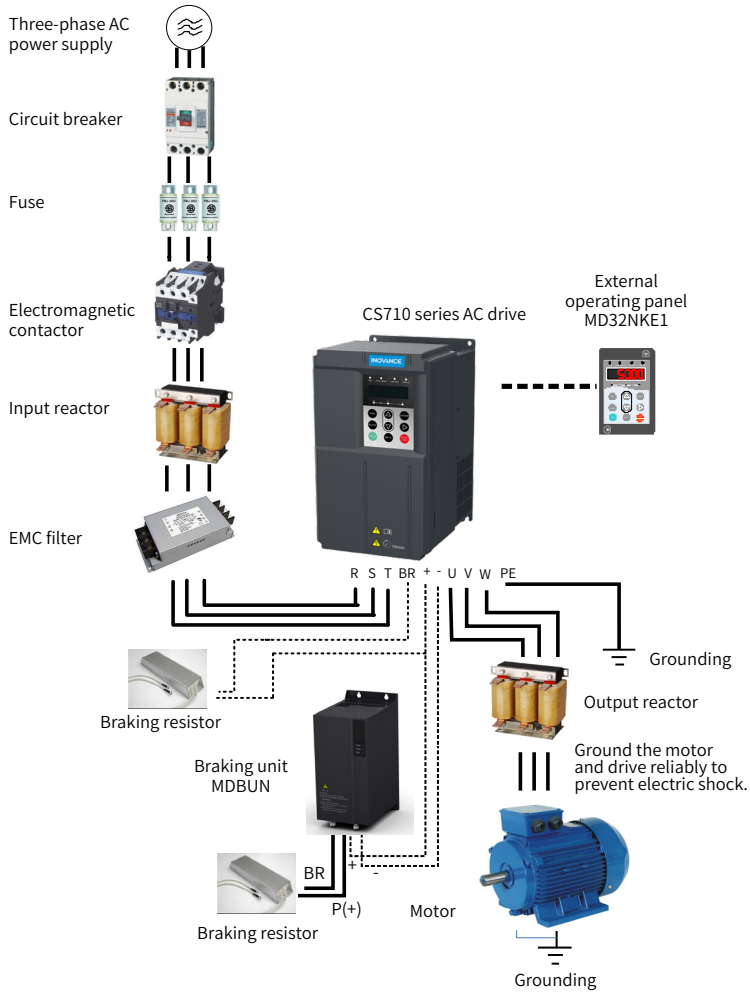

Figure 2-1 CS710 series AC drive system composition

**NOTE**

- ◆ The preceding figure is only a schematic system connection diagram of the CS710 AC drive. For the selection of peripherals, see "[9 Technical Data and Model Selection](#)".

2.2 Description of Peripheral Electrical Devices

Table 2-1 Description of peripheral electrical devices of the CS710 series AC drive

Device	Mounting Location	Function Description
Breaker	Between the power source and AC drive input side	MCCB: Cuts off power supply when overcurrent occurs on downstream devices.
		Leakage breaker: Provides protection against potentially leakage current during AC drive running to prevent electric shock and even a fire.
Fuse	Between the power source and AC drive input side	Protects downstream semiconductors in case of short circuits.
(Electromagnetic) Contactor	Between the breaker and AC drive input side	Switches ON/OFF the AC drive. Do not start/stop the AC drive frequently using the contactor (keep an interval of at least 1 hour between ON and OFF operations) or use it to directly start the AC drive.
Input reactor	AC drive input side	Improves the power factor of the power input side. Eliminates higher harmonics of the input side effectively and prevents damages to other devices caused by the distortion of voltage waveform. Eliminates input current unbalance due to inter-phase unbalance.
EMC filter	AC drive input side	Reduces external conduction and radiation interference of the AC drive. Decreases conduction interference flowing from the power supply to the AC drive and improves the anti-interference capacity of the AC drive.
DC reactor	Standard configuration for drives of 30 kW or higher rating and optional for drives of 18.5 to 22 kW	Improves the power factor of power input side. Improves efficiency and thermal stability of the AC drive. Reduces the impact of higher harmonics of the AC drive input side and reduces external conduction and radiation interference.
Braking resistor	Connected to the drive (75 kW or lower rating) or to the MDBUN braking unit (90 kW or higher rating).	Use the braking resistor to dissipate regenerated energy during motor deceleration or regenerative condition (load going down).

Device	Mounting Location	Function Description
Braking unit	Models of 90 kW or higher rating	Use Inovance's braking unit MDBUN and recommended braking resistor for models of 90 kW or higher rating.
Output reactor	Between AC drive output side and the motor, close to the AC drive	<p>The output side of AC drive generally has much higher harmonics. When the motor is far from the AC drive, there is high distributed capacitance in the circuit, and certain harmonics may cause resonance in the circuit, which will:</p> <p>a) Degrade motor insulation performance and damage motor in long run.</p> <p>b) Generate large leakage current and cause frequent AC drive protection trips.</p> <p>If the distance between the AC drive and motor is greater than 100 m, install an AC output reactor.</p>
dv/dt reactor	At the AC drive output side and close to the AC drive	(Optional) Protects motor insulation and reduces bearing current.
Output magnetic ring	At the AC drive output side and close to the AC drive	Reduces bearing current.
Motor	At the AC drive output side	Select an appropriate motor.



- ◆ Do not install a capacitor or surge suppressor on the output side of the AC drive. Otherwise, the AC drive may be damaged.
- ◆ Inputs/Outputs (main circuit) of the AC drive contain harmonics, which may interfere with communication devices connected to the AC drive. Therefore, install an anti-interference filter to minimize interference.

3 Installation and Wiring

3.1 Installation

3.1.1 Installation Environment

- 1) Ambient temperature: The AC drive service life is greatly influenced by the ambient temperature. Do not run the AC drive under a temperature beyond the allowed temperature range (-10°C to +50°C).
- 2) Install the AC drive on the surface of a flame retardant object, and ensure there is sufficient space around the enclosure to allow for efficient heat dissipation. The AC drive generates great heat during working. Use screws to install the AC drive on the mounting support vertically.
- 3) Install the AC drive in a place without strong vibration. Ensure that the mounting location is not affected by levels of vibration that exceeds 0.6G. Keep the AC drive away from punch machines.
- 4) Ensure that the mounting location is away from direct sunlight, damp, or water drops.
- 5) Ensure that the mounting location is protected against corrosive, combustible, or explosive gases and vapors.
- 6) Ensure that the mounting location is free from oil and dust.

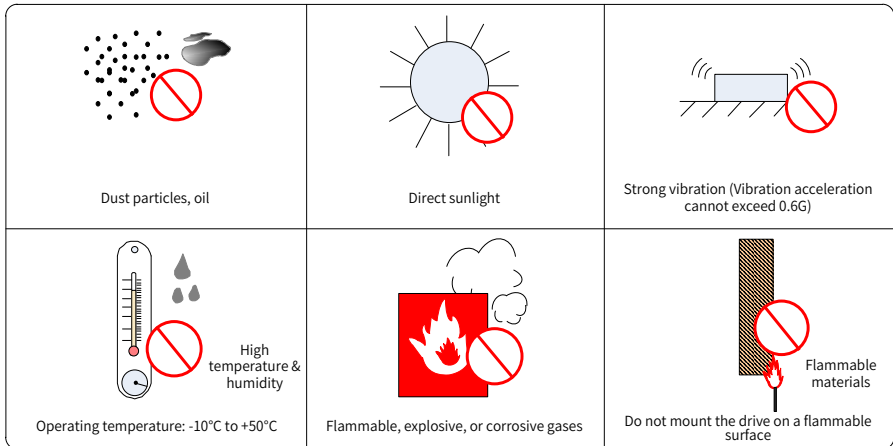

Figure 3-1 Installation environment requirements

- 7) The AC drive must be installed in a fireproof cabinet with doors that provide effective electrical and mechanical protection. The installation must conform to local and regional laws and regulations, and to relevant IEC requirements.

3.1.2 Mounting Clearance and Orientation

1 Mounting Clearance

The mounting clearance varies with the power rating of the AC drive.

■ Mounting of a single drive

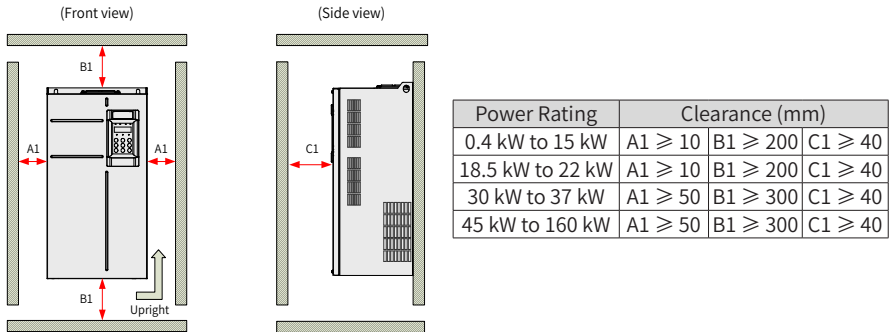

Figure 3-2 Installation clearance for a single drive (three-phase 380–480 V, 0.4–160 kW)

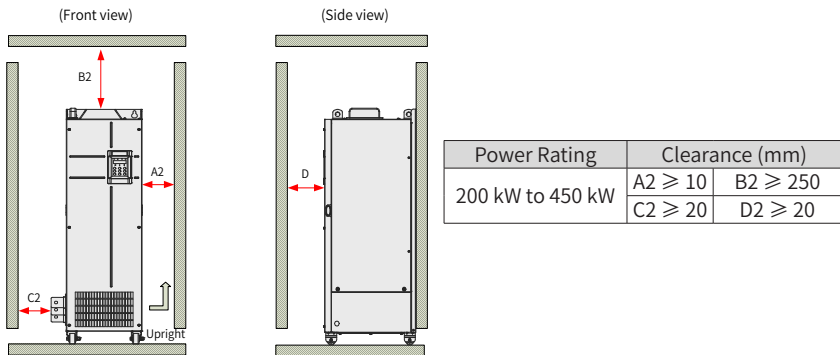

Figure 3-3 Installation clearance for a single drive [three-phase 380-480 V, 200-450 kW]

■ Mounting of multiple drives

The CS710 series drive uses a bottom-up cooling airflow design. If multiple AC drives are used together, line up the tops of the AC drives.

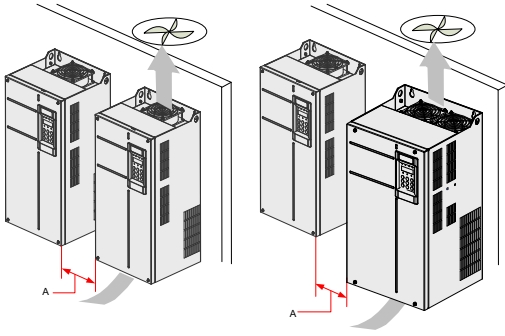

Figure 3-4 Installation clearance for parallel installation of multiple drives

If one row of AC drives need to be installed above another row, install an air guide plate to prevent AC drives in the lower row from heating those in the upper row, which may cause failures of the upper drives.

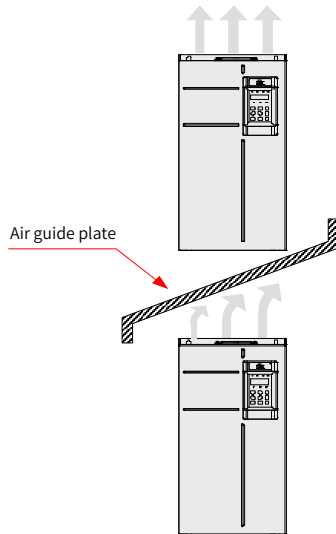

Figure 3-5 Installation of drives in upper and lower rows



NOTE

◆ This installation method is not allowed for drives of 200 kW to 450 kW.

2 Mounting Orientation

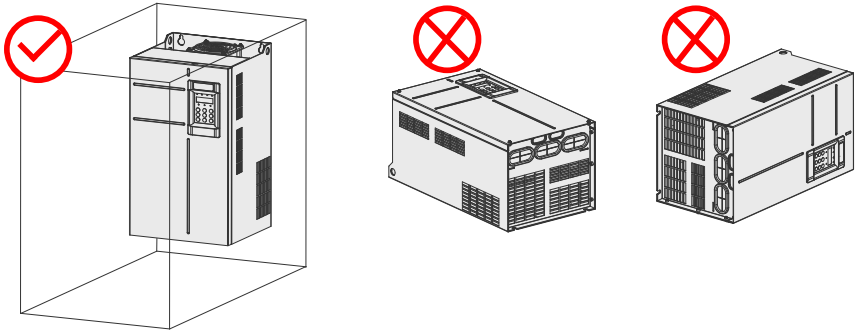

Figure 3-6 Correct and incorrect mounting orientations

3.1.3 Installation Instructions

The applicable installation method varies with power ratings of different models in the CS710 series. Follow the following guidance for the specific model and application scenario.

1 Backplate Mounting and Through-Hole Mounting for 0.4 to 160 kW Models

■ Backplate mounting

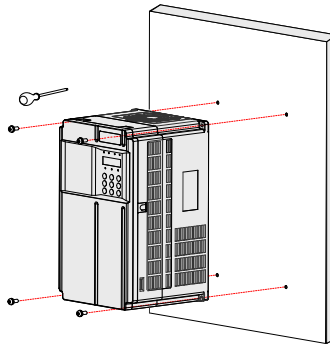

Figure 3-7 Backplate mounting of 0.4 to 37 kW models

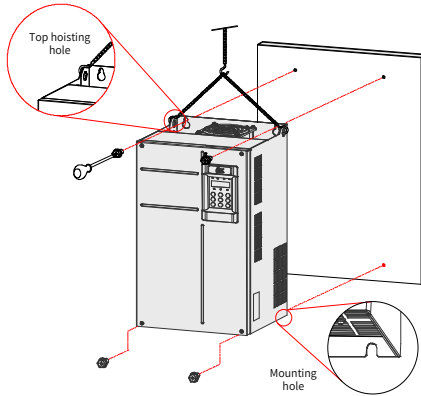

Figure 3-8 Backplate mounting of 45 to 160 kW models



◆ When using this installation method, do not secure the AC drive with only the upper two screws, because the AC drive may fall due to uneven force after long-time running. Ensure that all the four screws are fastened.

■ Through-hole mounting

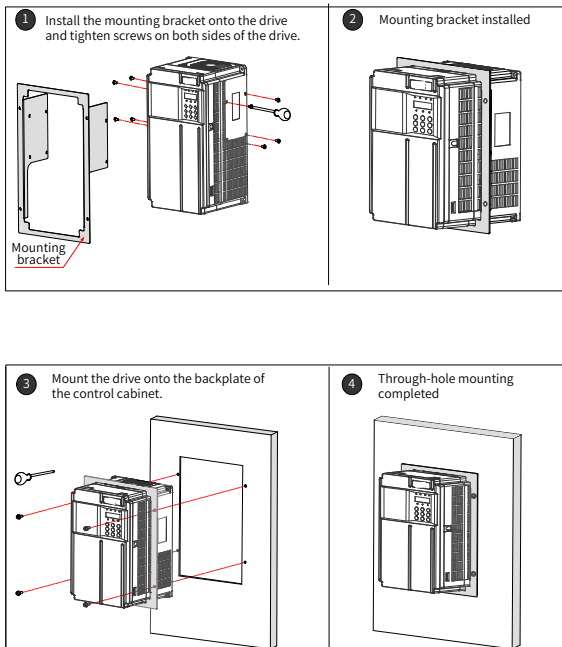

Figure 3-9 Through-hole mounting of 0.4 to 37 kW models

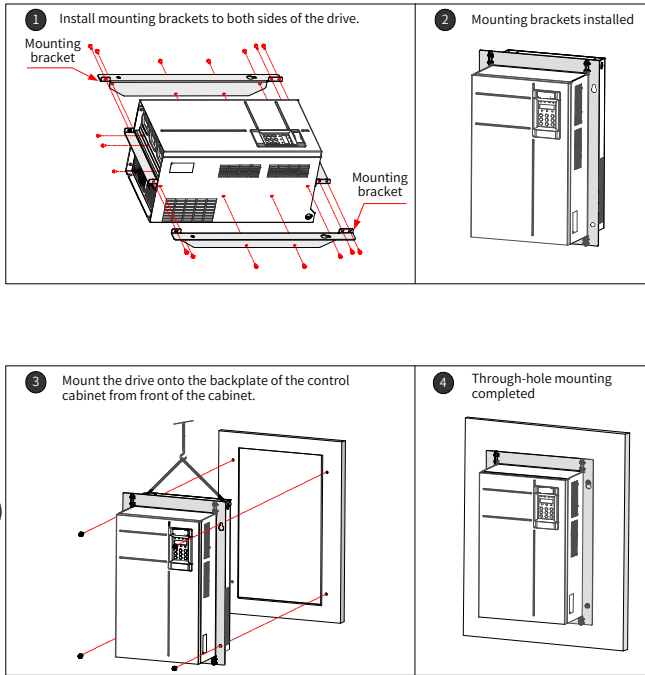

Figure 3-10 Through-hole mounting of 45 to 160 kW models

■ Mounting bracket models for through-hole mounting

Table 3-1 List of mounting bracket models for through-hole mounting

Mounting Bracket Model	Applicable Drive Model
MD500-AZJ-A1T1	CS710-4T0.4GB
	CS710-4T0.7GB
	CS710-4T1.1GB
	CS710-4T1.5GB
	CS710-4T2.2GB
MD500-AZJ-A1T2	CS710-4T3.0GB
	CS710-4T3.7GB
MD500-AZJ-A1T3	CS710-4T5.5GB
	CS710-4T7.5GB
MD500-AZJ-A1T4	CS710-4T11GB
	CS710-4T15GB

Mounting Bracket Model	Applicable Drive Model
MD500-AZJ-A1T5	CS710-4T18.5GB
	CS710-4T22GB
MD500-AZJ-A1T6	CS710-4T30GB
	CS710-4T37GB
MD500-AZJ-A1T7	CS710-4T45GB
	CS710-4T55GB
MD500-AZJ-A1T8	CS710-4T75GB
	CS710-4T90G
	CS710-4T110G
MD500-AZJ-A1T9	CS710-4T132G
	CS710-4T160G

3.1.4 Mounting in a Cabinet

1 Ventilation

Only one AC drive of models CS710-4T200G to CS710-4T450G can be mounted in a cabinet. Reserve sufficient ventilation space around the AC drive. Follow the following guidance for the specific model and application scenario.

■ Cabinet without fans on the top

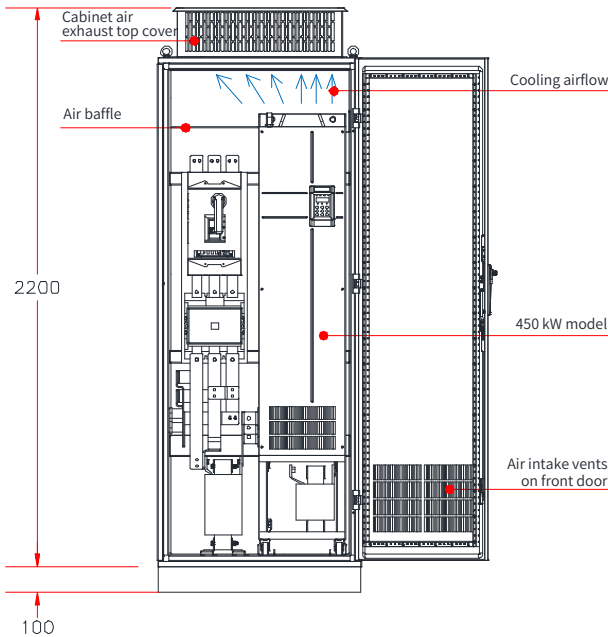

Figure 3-11 Self-ventilated cabinet

Table 3-2 Specification of a self-ventilated cabinet

AC Drive Model	Quantity of Fans	Total Air Volume (CFM)	Effective Area of Cabinet Top Air Inlet (mm ²)	Effective Area of Cabinet Top Air Outlet (mm ²)
CS710-4T132G	2	541	31809	50894
CS710-4T160G	2	620	31809	50894
CS710-4T200G (-L)	2	586	31809	50894
CS710-4T220G (-L)	2	722	31809	50894
CS710-4T250G (-L)	3	789	47713	76341
CS710-4T280G (-L)	3	882	47713	76341
CS710-4T315G (-L)	3	644	47713	76341
CS710-4T355G (-L)	3	796	47713	76341
CS710-4T400G (-L)	3	796	47713	76341
CS710-4T450G (-L)	3	796	47713	76341

Note:
CFM = 0.0283 m³/min
Effective area means the through-hole area.

■ Cabinet with fans on the top

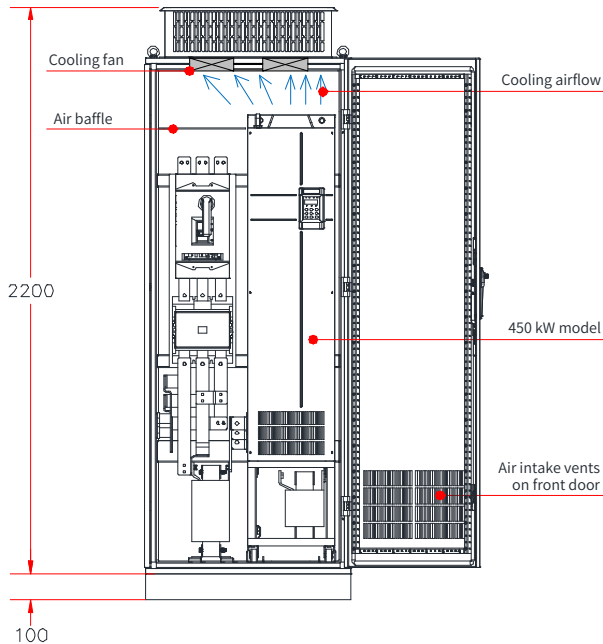

Figure 3-12 Force fan ventilated cabinet

Table 3-3 Specification of a force fan ventilated cabinet

AC Drive Model	Quantity of Fans	Total Air Volume (CFM)	Effective Area of Cabinet Top Air Inlet (mm ²)	Max. Air Volume Required by the Top Fans (CFM)	Effective Area of Cabinet Top Air Outlet (mm ²)
CS710-4T132G	2	541	31809	649	S = 0.942 x N x (Dout2-DHUB2)
CS710-4T160G	2	620	31809	744	
CS710-4T200G (-L)	2	586	31809	703	In the preceding formula, N means the number of top fans, Dout means the diameter of the top fan, and DHUB means the diameter of the top fan center HUB.
CS710-4T220G (-L)	2	722	31809	866	
CS710-4T250G (-L)	3	789	47713	947	
CS710-4T280G (-L)	3	882	47713	1058	
CS710-4T315G (-L)	3	644	47713	773	
CS710-4T355G (-L)	3	796	47713	955	
CS710-4T400G (-L)	3	796	47713	955	
CS710-4T450G (-L)	3	796	47713	955	

Note:
 CFM = 0.0283 m³/min
 Effective area means the through-hole area.

As shown in the following figure, an insulation barrier is required to prevent hot air circulating inside the cabinet and ensure that hot air can be exhausted out of outlets on the top.

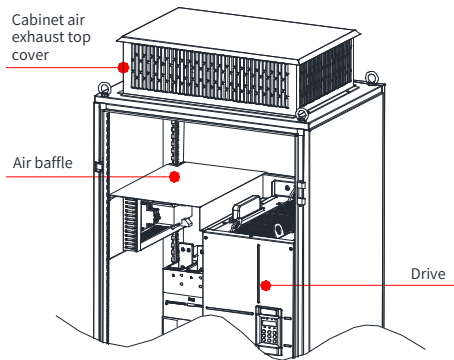

Figure 3-13 Insulation barrier in the cabinet

2 Precautions

A nine-folding AL cabinet (PS cabinet) is recommended. Before installing the AC drive, check whether fixing beams with fixing holes are mounted to the cabinet back correctly. Then install the bottom mounting bracket and guide rails. Reserve sufficient space at the bottom of the cabinet for side entry copper bar joint and operation.

You can move the AC drive into or out of the cabinet with the casters over the guide rails. Align the casters to the guide rails before moving the AC drive into or out of the cabinet. The AC drive must be moved by two persons to ensure personal safety.



Caution

- ◆ Reserve sufficient installation space to ensure sufficient clearance for efficient heat dissipation of the AC drive and other devices in the cabinet.
- ◆ Use an extended rod sleeve to operate on copper terminals of power lines in the main circuit.
- ◆ Align the casters to the guide rails before moving the AC drive into or out of the cabinet. The AC drive must be moved by two persons to ensure personal safety.
- ◆ See the following cabinet layout diagram before mounting the AC drive in the cabinet. The cabinet dimensions are 2200 mm x 800 mm x 600 mm. The 2200 mm height includes the 200 mm ventilation top cover but does not include the 100 mm cabinet base. A wind screen must be installed at the top of the cabinet to avoid ventilation airflow circulation. In addition, air inlet openings must be reserved at the bottom of the cabinet.
- ◆ For dimensions of the mounting bracket (delivered with the AC drive), see "[9 Technical Data and Model Selection](#)". The guide rails must have enough strength and stiffness.
- ◆ After moving the AC drive into the cabinet, remove the baffle on the top of the AC drive to prevent overheating of the AC drive.
- ◆ Backplate mounting is not available for AC drives of 200 kW to 450 kW, because suspended devices may be damaged during transportation or in environments with strong vibration. The AC drives of 200 kW to 450 kW must be installed with mounting brackets or bases at the bottom in cabinets.

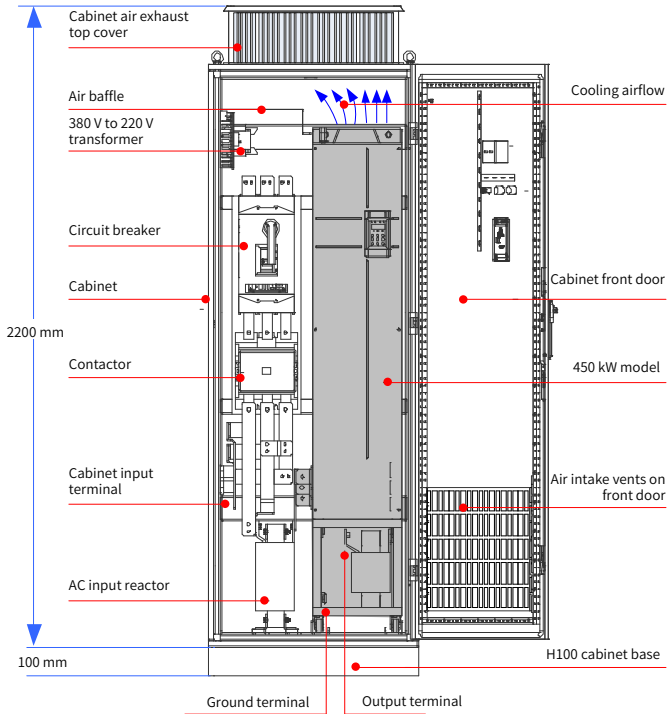

Figure 3-14 Recommended cabinet layout

3 Steps of Installing the AC Drive in the Cabinet

Step	Description
1	Install the fixing beam in the nine-folding AL cabinet.
2	Secure the bottom mounting bracket in the cabinet.
3	Assemble the guide rails (optional) and install them in the cabinet.
4	Remove the cover from the AC drive to expose the handle.
5	Require two persons to align casters of the AC drive to the guide rails and push the AC drive into the cabinet slowly. Use a soft strap when moving the AC drive into or out of the cabinet to prevent turnover.
6	Remove the soft strap. Secure the AC drive to the fixing beam by tightening screws in the two mounting holes on the top and bottom at the back of the AC drive.
7	After verifying that the AC drive is securely mounted, remove the guide rails.

■ Securing the fixing beam and reserve mounting holes

- 1) A nine-folding AL cabinet (PS cabinet) is recommended. Figure 3-15 shows the cross section of the nine-folding AL cabinet.
- 2) When an AC drive of CS710-4T200G(-L) to CS710-4T450G(-L) is mounted in a 600-mm deep nine-folding AL cabinet, the fixing beam must be folded inwards to leave more space for the AC drive, as shown in Figure 3-16. This is not required when the AC drive is mounted in an 800-mm or deeper cabinet.

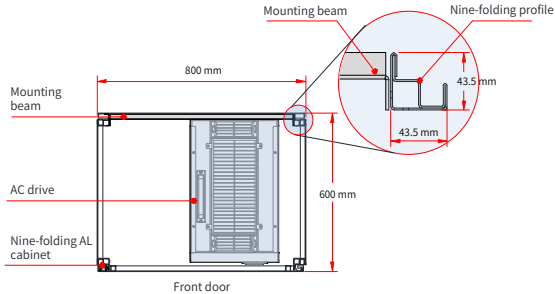

Figure 3-15 Top view of a 200-450 kW cabinet

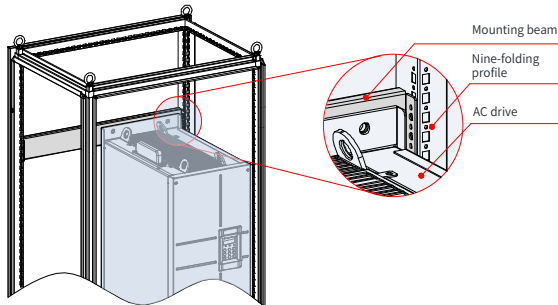

Figure 3-16 3D view of a 200-450 kW cabinet



- ◆ If the cabinet has front and back doors, the 600-mm depth is not enough for an AC drive of CS710-4T200G(-L) to CS710-4T450G(-L). In this case, an 800-mm deep cabinet is recommended.

■ Fixing the bottom mounting bracket

- 1) Use six M5 tapping screws to fix the mounting bracket on the base of the nine-folding AL cabinet according to the following figure.
- 2) If a non-nine-folding AL cabinet is used, drill mounting holes for the mounting bracket on site.

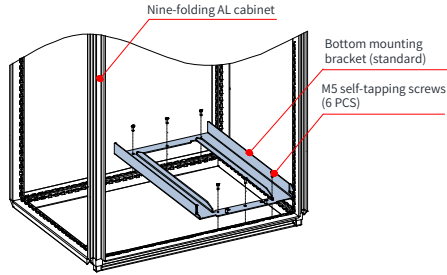

Figure 3-17 Installing the bottom mounting bracket

- Assembling the guide rails (model: MD500-AZJ-A3T10, optional)
- 1) Assemble the guide rails of the correct model according to Figure A. Figure B shows the assembled guide rails.
- 2) Align the two holes at front of the guide rails with screws of the mounting bracket, and fix them with two M6 nuts, as shown in Figure C.

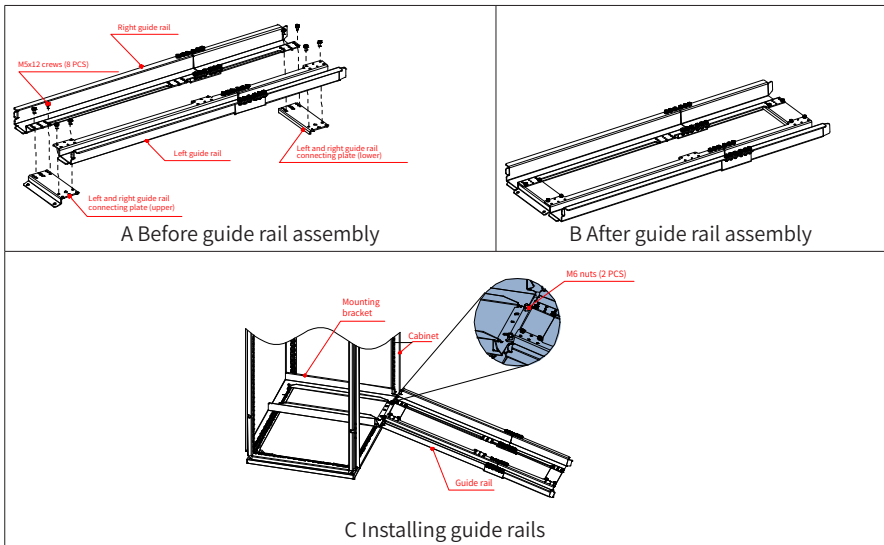

Figure 3-18 Installing guide rails in the cabinet

Read the MD500-AZJ-A3T10 Guide Rail Assembly Instruction before assembling the guide rails.

■ Installing the AC drive in the cabinet

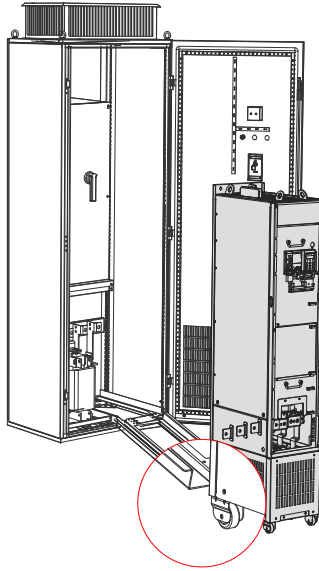

Figure 3-19 Aligning casters of the AC drive with the guide rails

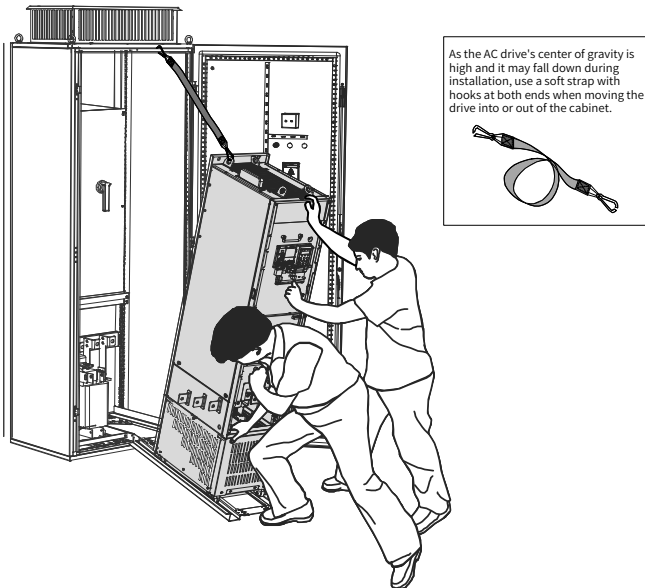

Figure 3-20 Pushing the AC drive into the cabinet

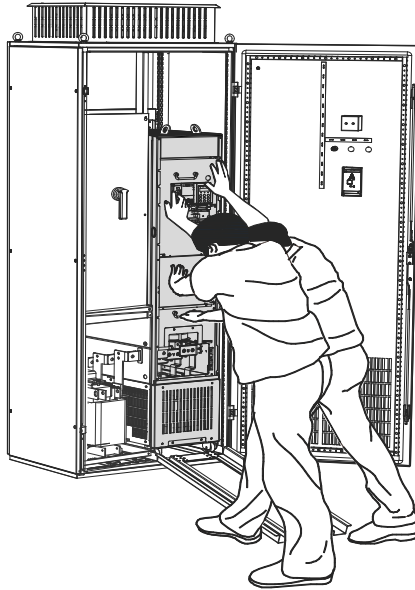

Figure 3-21 AC drive pushed into the cabinet

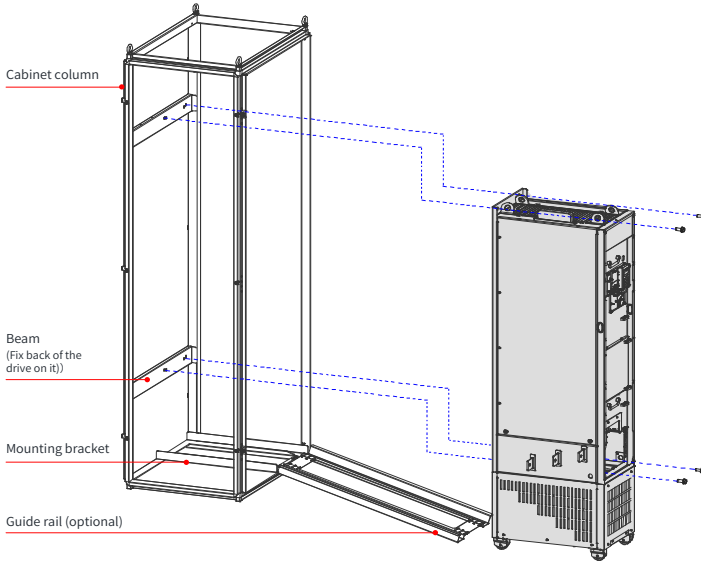

Figure 3-22 Fixing the AC drive to the beams on the back of the cabinet through the four mounting holes on the back of the AC drive

3 Precautions

Remove the AC drive from the cabinet in reverse order of the preceding steps.

Ensure that the four mounting holes on the back of the AC drive are connected to the beams securely.

After installing the AC drive, remove the baffle on the top of the AC drive. The baffle is used to prevent foreign objects such as screws from falling into the ventilation channel when mounting the AC drive in the cabinet.

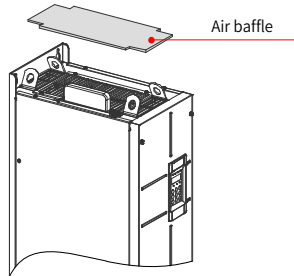

Use top hoist rings to move or hoist the AC drive. If the AC drive is placed horizontally, use the top hoist ring and bottom hoist hole when you hoist the AC drive again. Do not apply force on the DC bus terminals.

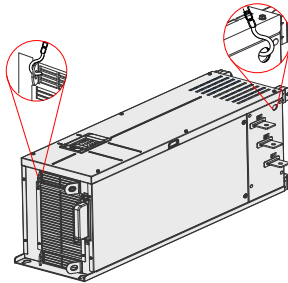

If the AC drive is placed vertically, do not apply force on two sides of the AC drive or place the AC drive on an inclined plane. The AC drive weighs almost 200 kg and may fall down if the slope exceeds 5°.

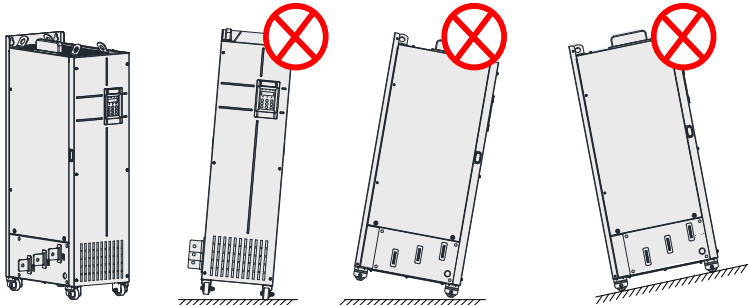

3.1.5 Removing and Installing the Cover

Before connecting the main circuits and control circuits of the AC drive, remove its cover.

 Danger	<ul style="list-style-type: none"> ◆ Remove the cover after the AC drive has been kept power-off for more than 10 minutes. ◆ Be careful when removing the cover. A falling cover may cause personal injury.
---	---

1 Removing and Installing the Cover of 0.4-37 kW Models

Removal		
<p>Use a screwdriver to pinch inwards the latches on both sides of the cover to release the cover.</p> 	<p>Hold the cover with both hands.</p> <ol style="list-style-type: none"> 1) Lift the lower part of the cover. 2) Slightly push forward and lift the upper part of the cover. 	<p>The cover is removed.</p> 
Installation		
<p>Hold the cover with both hands and fix the hook on the top edge in the fixing hole.</p> 	<p>Align the cover with the AC drive and push it down in the arrow direction until the side latches are in place.</p> 	<p>The cover is installed.</p> 

Figure 3-23 Removing and installing the cover of 0.4-37 kW models

2 Removing and Installing the Cover of 45–160 kW Models

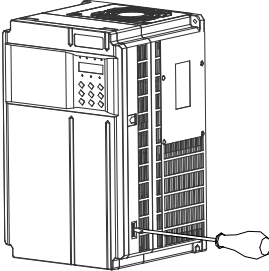
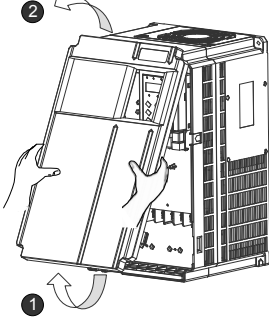
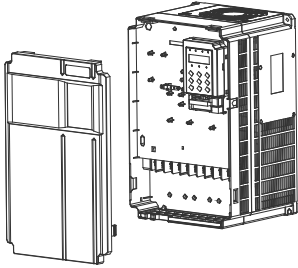
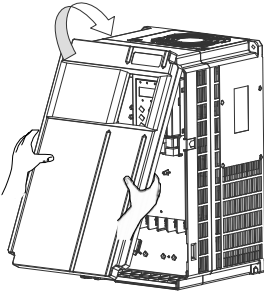
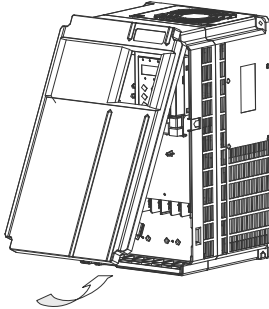
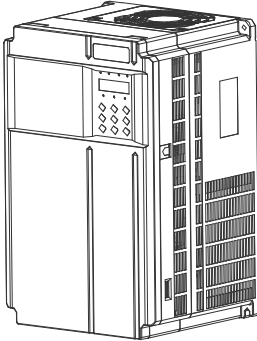
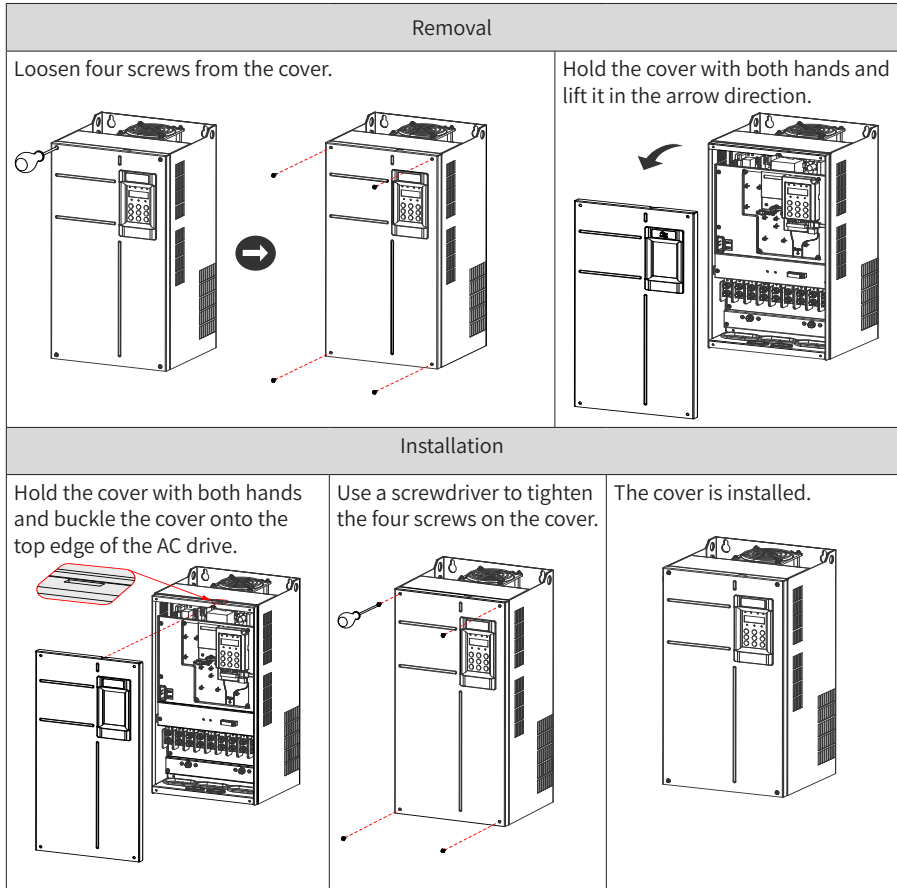

Figure 3-24 Removing and installing the cover of 45–160 kW models

3 Removing and Installing the Cover of 200–450 kW Models

Removal	
<p>Loosen six screws from the cover.</p>	<p>Hold the cover with both hands and pull it up in the arrow direction.</p>
	
Installation	
<p>1) Hold the cover with both hands and buckle the cover onto the top edge of the AC drive. Align the six screw mounting holes on the cover with the fixing holes on the AC drive, and attach the cover close to the AC drive.</p>	<p>2) Tighten the six screws with a screwdriver to secure the cover.</p>
	

Figure 3-25 Removing and installing the cover of 200–450 kW models

3.2 Wiring

3.2.1 Standard Wiring Diagram

As shown in the following figure, the wiring part marked by the double-headed arrow differs in 0.4 to 75 kW and 90 to 400 kW models.

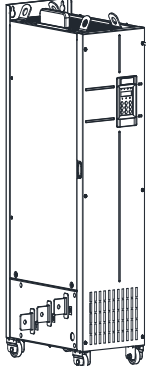
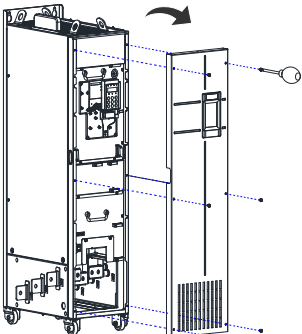
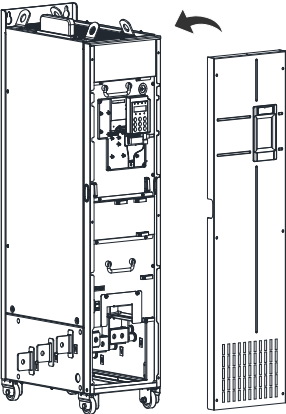
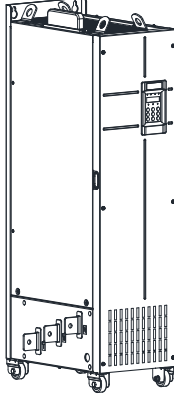
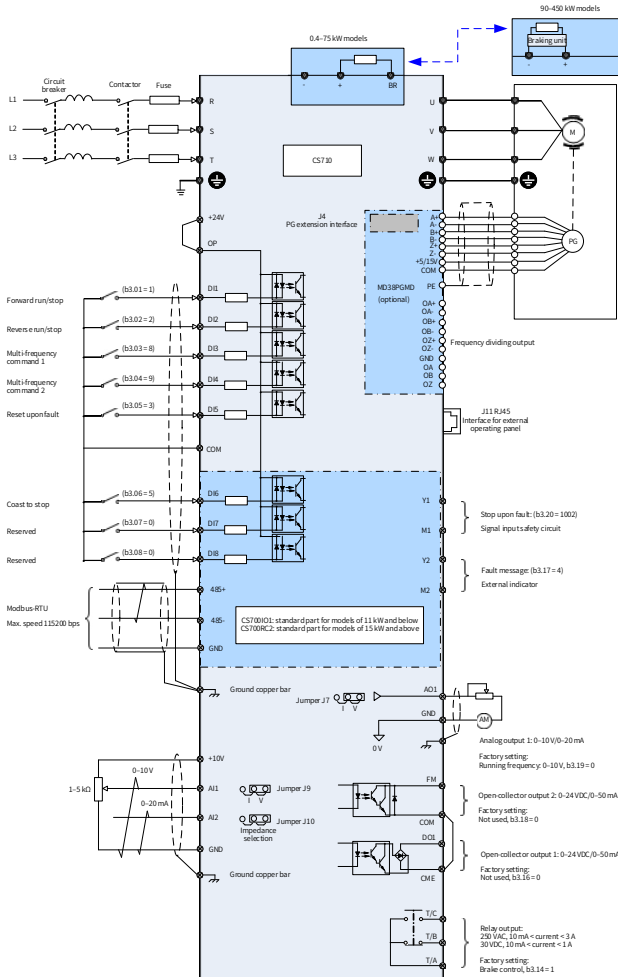

Note: —shield; —twisted pair

Figure 3-26 Typical wiring diagram of a three-phase 380–480 V AC drive

3.2.2 Main Circuit Terminals

1 Main Circuit Terminals of the CS710 Series AC Drives

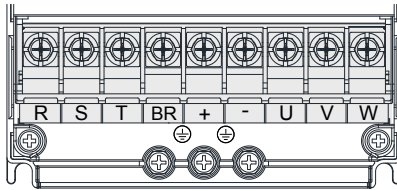

Figure 3-27 Main circuit terminal arrangement on 0.4–15 kW AC drives

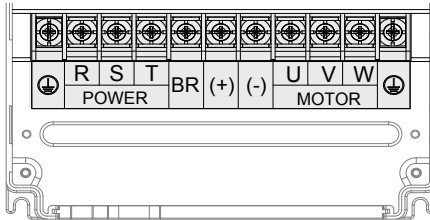
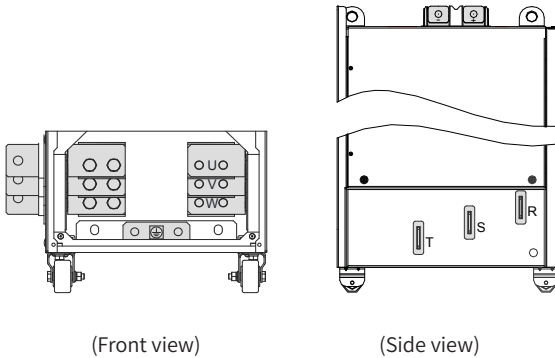

Figure 3-28 Main circuit terminal arrangement on 18.5–160 kW AC drives



(Front view)

(Side view)

Figure 3-29 Main circuit terminal arrangement on 200–450 kW AC drives

Table 3-4 Description of main circuit terminals of CS710 series AC drives

Terminal Symbol	Terminal Name	Description
R, S, T	Three-phase supply input	Connected to three-phase power supply
(+), (-)	DC bus terminals	Connected to the external braking unit (MDBUN) of an AC drive with 90 kW or higher power rating
(+), BR	Braking resistor connection terminals	Connected to the external braking resistor of an AC drive of 75 kW or lower rating
U, V, W	AC drive outputs	Connected to a three-phase motor
	Ground (PE) terminal	Connected to the protection ground point

2 Main Circuit Cable Selection

Inovance recommends symmetrical shielded cables as main circuit cables, which can reduce electromagnetic radiation of the entire conductive system compared with four-core cables.

- Recommended power cable: symmetrical shielded cable

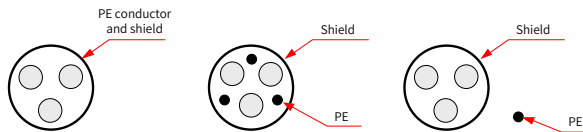

Figure 3-30 Recommended power cables

- Not-recommended power cable



Figure 3-31 Not-recommended power cables

3 Power inputs R, S, T

- There are no phase sequence requirements for input cable connections.
- Specifications and installation of all external power cables must comply with local safety regulations and relevant IEC standards.
- Select copper wires of appropriate sizes according to recommendations provided in ["9 Technical Data and Model Selection"](#).
- Install the filter close to the power input side of the AC drive with a cable shorter than 30 cm. Connect the ground terminal of the filter and the ground terminal of the AC drive together to the cabinet main grounding terminal.

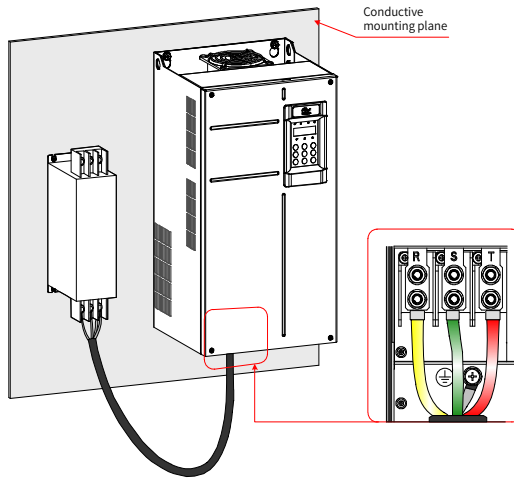

Figure 3-32 Mounting the filter

4 DC bus terminals (+) and (-)

- The DC bus terminals, labeled (+) and (-), carry a residual voltage for a period after the AC drive is switched off. To prevent electric shocks, connect cables to the terminals only when the CHARGE LED is off and the AC drive has been kept power-off for more than 10 minutes.
- To avoid the risk of equipment damage or fire, when you install an external braking unit for an AC drive of 90 kW or higher rating, do not reverse the poles (+) and (-).
- Use a cable of no more than 10 m to connect DC bus terminals to the external MDBUN braking unit. Use twisted pairs or close pair wires for this connection.
- Fire risk! Do not connect the braking resistor directly to the DC bus.

5 Braking Resistors (+) and BR

- They are connected to the external braking resistor of an AC drive of 75 kW or lower rating.
- To avoid the risk of equipment damage, select a braking resistor with recommended specifications and use a cable of no more than 5 m long to connect it.
- Do not place anything flammable around the braking resistor. Otherwise, adjacent devices may be burned once the braking resistor overheats.

6 AC Drive Outputs U, V, W

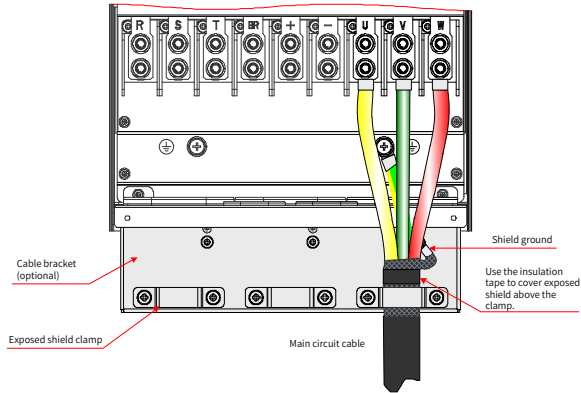

Figure 3-33 Shield wiring

The cable support bracket shown in the preceding figure needs to be purchased separately for an AC drive of 160 kW or lower rating. Install the cable support bracket following these instructions:

Installation Instructions	
<p>1) Remove the cover.</p> <p>2) Remove the two M4*12 screws on the inlet plate.</p>	<p>3) Install the cable support bracket onto the AC drive, and secure it with three M4*12 screws.</p>

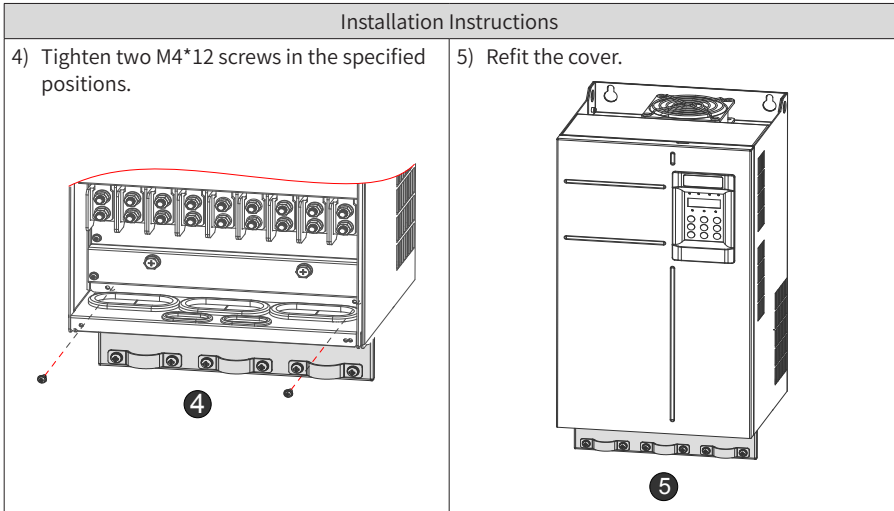

Figure 3-34 Installing the cable support bracket

Table 3-5 List of shield cable support bracket models

Cable Support Bracket Model	Applicable Drive Model
MD500-AZJ-A2T1	CS710-4T0.4GB
	CS710-4T0.7GB
	CS710-4T1.1GB
	CS710-4T1.5GB
	CS710-4T2.2GB
	CS710-4T3.0GB
MD500-AZJ-A2T2	CS710-4T3.7GB
	CS710-4T5.5GB
MD500-AZJ-A2T3	CS710-4T7.5GB
	CS710-4T11GB
MD500-AZJ-A2T4	CS710-4T15GB
MD500-AZJ-A2T5	CS710-4T18.5GB
	CS710-4T22GB
MD500-AZJ-A2T6	CS710-4T30GB
	CS710-4T37GB
MD500-AZJ-A2T7	CS710-4T45GB
	CS710-4T55GB

Cable Support Bracket Model	Applicable Drive Model
MD500-AZJ-A2T8	CS710-4T75GB
	CS710-4T90G
	CS710-4T110G
MD500-AZJ-A2T9	CS710-4T132G
	CS710-4T160G

- Specifications and installation of all cables connected to the AC drive outputs U, V, and W must comply with local safety regulations and relevant IEC standards.
- Select copper wires of appropriate sizes according to recommendations provided in ["9 Technical Data and Model Selection"](#).
- Do not connect any capacitor or surge absorber to the output side of the AC drive, as this can trigger the protection state frequently or even damage the AC drive.
- Long motor cables can cause electrical resonance due to distributed capacitance and inductance. Electrical resonance may damage the motor insulator or trigger overcurrent protection of the AC drive. To avoid these problems, install an AC output reactor close to the AC drive if the cable length exceeds 100 m.
- Shielded cables are recommended for the motor. The shield layer must be wound onto the cable support bracket. The drain wire must be grounded to the ground (PE) terminal.
- Keep the drain wire of the shield layer as short as possible and make sure that its width is no less than $1/5$ of its length.

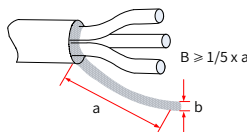

Figure 3-35 Drain wire of the shield layer

7 Ground (PE) Terminal

- For personal safety and reliability of the equipment, connect the ground (PE) terminal to an effective ground. The resistance value of the ground cable must be less than 10Ω .
- Do not connect the ground (PE) terminal to the neutral conductor of the power system.
- Select the ground conductor of an appropriate size according to ["9.4 Selection of Peripheral Electrical Devices"](#).
- Use a yellow/green ground cable to connect the ground conductor.
- Ground the shield.
- It is recommended that the AC drive be installed on a metal mounting surface. Ensure that the bottom of the AC drive is closely attached to the mounting surface.
- Install the filter and AC drive on the same mounting surface to ensure the filtering effect.

8 Main Circuit Cable Protection

- Add a heat shrink tubing to the cable lug copper tube and cores of main circuit cables and ensure that the heat shrink tubing completely covers the cable conductor, as shown in the following figure.

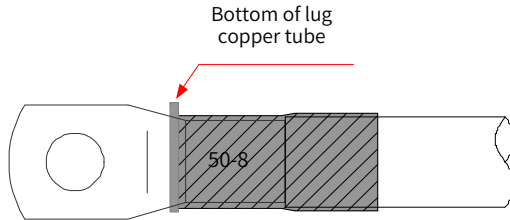

Figure 3-36 Heat shrink tubing covering the cable conductor

9 Power Input Protection

- Install protection devices at power input to the AC drive. The protection devices must provide protection against overcurrent and short-circuit, and be able to completely isolate the AC drive from the electrical power input.
- Cables and protection devices on power input must be suitably rated for the power and voltage class of the AC drive under normal conditions, and under possible fault conditions such as system overload and short-circuit on the power input. Use recommended values in ["9 Technical Data and Model Selection"](#).

10 Power Grid System Requirements

- The AC drive is applicable to a power grid system with the neutral point grounded. If the AC drive is used in an IT power system with an ungrounded neutral point, remove both VDR and EMC screws 1 and 2 shown in the figure. Do not install a filter. Failure to comply with this requirement may result in personal injury or damage to the AC drive.
- If a leakage circuit breaker is used and it trips at power-on, remove the EMC screw 2 shown in the figure.

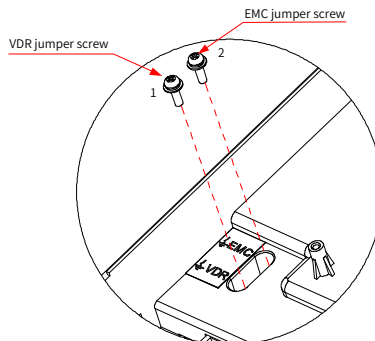

Figure 3-37 VDR screw and EMC screw

3.2.3 Layout and Dimensions of Main Circuit Terminals



NOTE

- ◆ By default, CS710-4T200G(-L) to CS710-4T450G(-L) are equipped with side entry copper bars, which can be removed as required.
- ◆ The recommended data and models in this section are for reference only. The cable diameter you select cannot be larger than the size in the figures in this section.
- ◆ IEC cables are selected based on:
 - EN 60204-1 and IEC 60364-5-52 standards
 - PVC insulation
 - 40° C ambient temperature and 70° C surface temperature
 - Symmetrical cable with copper mesh shield
 - A maximum of nine cables are allowed in a cable tray.
- ◆ In the tables in this section, 3 x 10 indicates a 3-core cable, and 2 x (3 x 95) indicates two 3-core cables.

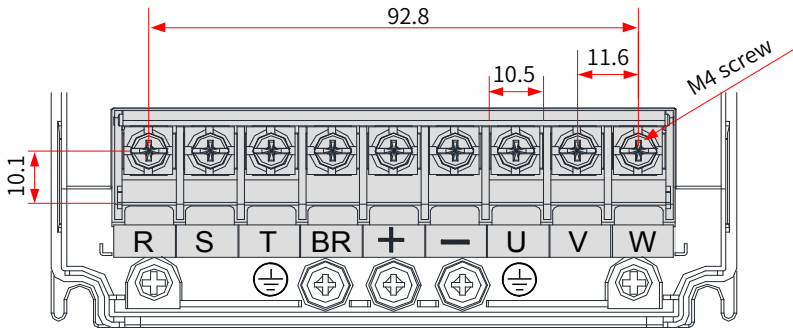

Figure 3-38 Dimensions of the main circuit terminals (CS710-4T0.4GB to CS710-4T5.5GB, three phase 380–480 V)

Table 3-6 Recommended main circuit cables for CS710-4T0.4GB to CS710-4T5.5GB (three phase 380–480 V)

AC Drive Model	Rated Input Current (A)	Power Input/ Output Cable (mm ²)	Lug Model	Ground Cable (mm ²)	Ground Cable Lug Model	Tightening Torque (N·m)
CS710-4T-0.4GB	1.8	3 x 0.75	TNR0.75-4	0.75	TNR0.75-4	1.2
CS710-4T-0.7GB	2.4	3 x 0.75	TNR0.75-4	0.75	TNR0.75-4	1.2
CS710-4T-1.1GB	3.7	3 x 0.75	TNR0.75-4	0.75	TNR0.75-4	1.2
CS710-4T-1.5GB	4.6	3 x 0.75	TNR0.75-4	0.75	TNR0.75-4	1.2
CS710-4T-2.2GB	6.3	3 x 0.75	TNR0.75-4	0.75	TNR0.75-4	1.2
CS710-4T-3.0GB	9.0	3 x 1	TNR1.25-4	1	TNR1.25-4	1.2
CS710-4T-3.7GB	11.4	3 x 1.5	TNR1.25-4	1.5	TNR1.25-4	1.2
CS710-4T-5.5GB	16.7	3 x 2.5	TNR2-4	2.5	TNR2-4	1.2

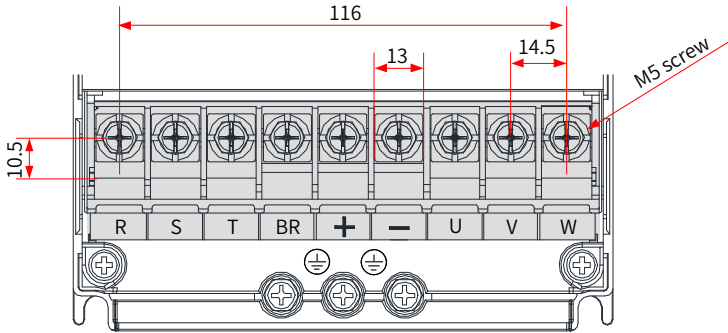

Figure 3-39 Dimensions of the main circuit terminals (CS710-4T7.5GB/CS710-4T11GB, three phase 380–480 V)

Table 3-7 Recommended main circuit cables for CS710-4T7.5GB/CS710-4T11GB (three phase 380–480 V)

AC Drive Model	Rated Input Current (A)	Power Input/ Output Cable (mm ²)	Lug Model	Ground Cable (mm ²)	Ground Cable Lug Model	Tightening Torque (N·m)
CS710-4T7.5GB	21.9	3 x 4	TNR3.5-5	4	TNR3.5-5	2.8
CS710-4T11GB	32.2	3 x 6	TNR5.5-5	6	TNR5.5-5	2.8

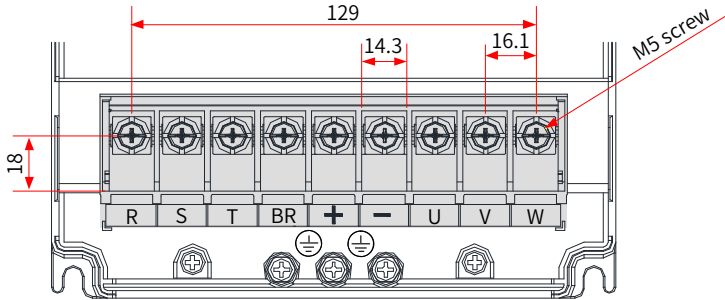

Figure 3-40 Dimensions of the main circuit terminals (CS710-4T15GB, three phase 380–480 V)

Table 3-9 Recommended main circuit cables for CS710-4T15GB (three phase 380–480 V)

AC Drive Model	Rated Input Current (A)	Power Input/ Output Cable (mm ²)	Lug Model	Ground Cable (mm ²)	Ground Cable Lug Model	Tightening Torque (N·m)
CS710-4T15GB	41.3	3 x 10	TNR8-5	10	TNR8-5	2.8

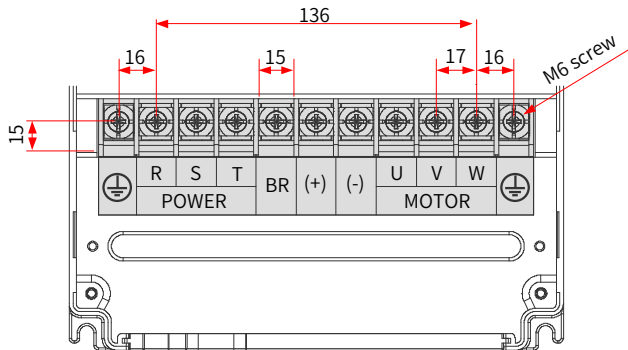

Figure 3-41 Dimensions of the main circuit terminals (CS710-4T18.5GB(-T)/CS710-4T22GB(-T), three phase 380–480 V)

Table 3-10 Recommended main circuit cables for CS710-T18.5GB(-T)/CS710-4T22GB(-T) (three phase 380–480 V)

AC Drive Model	Rated Input Current (A)	Power Input/ Output Cable (mm ²)	Lug Model	Ground Cable (mm ²)	Ground Cable Lug Model	Tightening Torque (N·m)
CS710-4T18.5GB(-T)	49.5	3 x 10	GTNR10-6	10	GTNR10-6	4.0
CS710-4T22GB(-T)	59	3 x 16	GTNR16-6	16	GTNR16-6	4.0

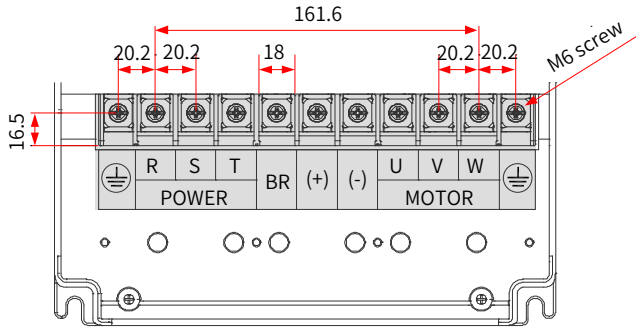

Figure 3-42 Dimensions of the main circuit terminals (CS710-4T30GB/CS710-4T37GB, three phase 380–480 V)

Table 3-11 Recommended main circuit cables for CS710-4T30GB/CS710-4T37GB (three phase 380–480 V)

AC Drive Model	Rated Input Current (A)	Power Input/ Output Cable (mm ²)	Lug Model	Ground Cable (mm ²)	Ground Cable Lug Model	Tightening Torque (N·m)
CS710-4T30GB	57	3 x 16	GTNR16-6	16	GTNR16-6	4.0
CS710-4T37GB	69	3 x 25	GTNR25-6	16	GTNR16-6	4.0

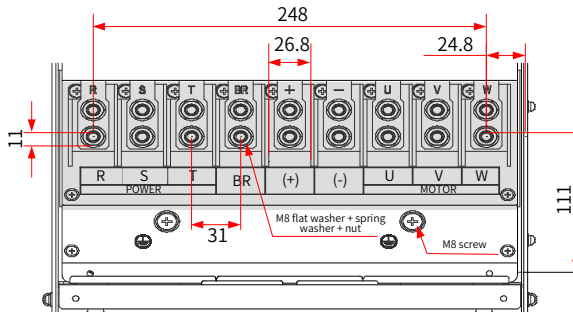

Figure 3-43 Dimensions of the main circuit terminals (CS710-4T45GB/CS710-4T55GB, three phase 380–480 V)

Table 3-12 Recommended main circuit cables for CS710-4T45GB/CS710-4T55GB (three phase 380–480 V)

AC Drive Model	Rated Input Current (A)	Power Input/ Output Cable (mm ²)	Lug Model	Ground Cable (mm ²)	Ground Cable Lug Model	Tightening Torque (N·m)
CS710-4T45GB	89	3 x 35	GTNR35-8	16	GTNR16-8	10.5
CS710-4T55GB	106	3 x 50	GTNR50-8	25	GTNR25-8	10.5

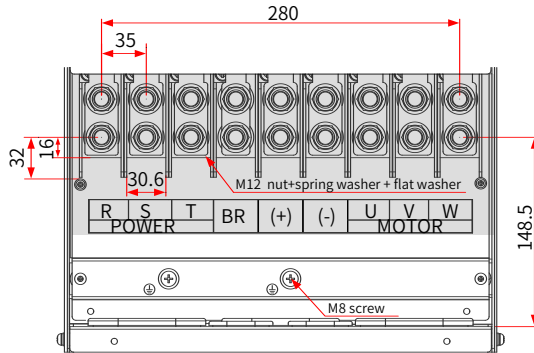

Figure 3-44 Dimensions of the main circuit terminals (CS710-4T75GB to CS710-4T110G, three phase 380–480 V)

Table 3-13 Recommended main circuit cables for CS710-4T75G to CS710-4T110G (three phase 380–480 V)

AC Drive Model	Rated Input Current (A)	Power Input/ Output Cable (mm ²)	Lug Model	Ground Cable (mm ²)	Ground Cable Lug Model	Tightening Torque (N·m)
CS710-4T75GB	139	3 x 70	GTNR70-12	35	GTNR35-12	35.0
CS710-4T90G	164	3 x 95	GTNR95-12	50	GTNR50-12	35.0
CS710-4T110G	196	3 x 120	GTNR120-12	70	GTNR70-12	35.0

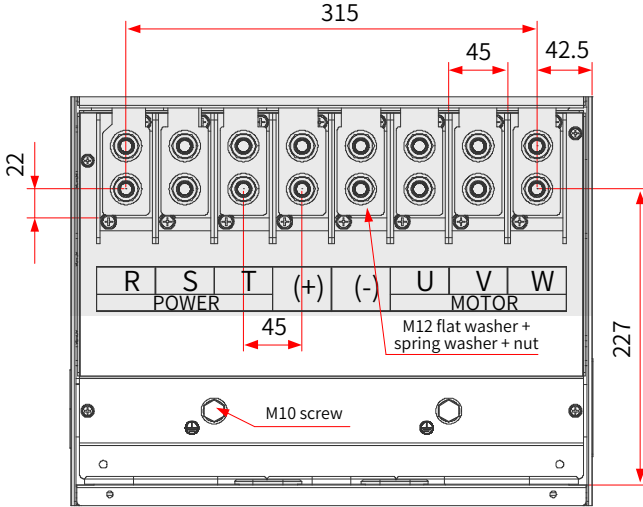

Figure 3-45 Dimensions of the main circuit terminals (CS710-4T132G/CS710-4T160G)

Table 3-14 Recommended main circuit cables for CS710-4T132G/CS710-4T160G

AC Drive Model	Rated Input Current (A)	Power Input/ Output Cable (mm ²)	Lug Model	Ground Cable (mm ²)	Ground Cable Lug Model	Tightening Torque (N·m)
CS710-4T132G	240	3 x 150	BC150-12	95	BC95-12	35.0
CS710-4T160G	287	3 x 185	BC185-12	95	BC95-12	35.0

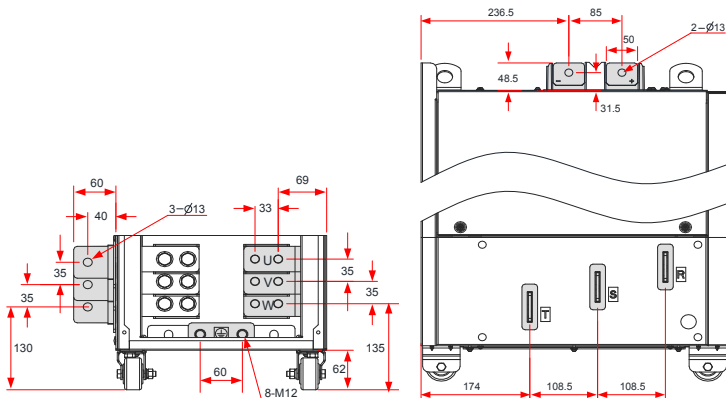

Figure 3-46 Dimensions of the main circuit terminals (CS710-4T200G/CS710-4T220G, without the output reactor)

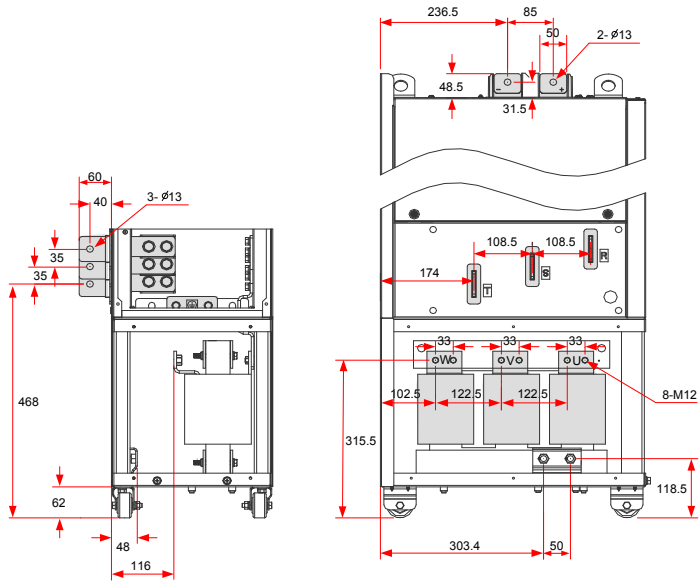

Figure 3-47 Dimensions of the main circuit terminals (CS710-4T200G-L/CS710-4T220G-L, with the output reactor)

The side entry copper bar in the preceding figures can be removed if necessary. The following figure shows the main circuit terminal dimensions without the side entry copper bar.

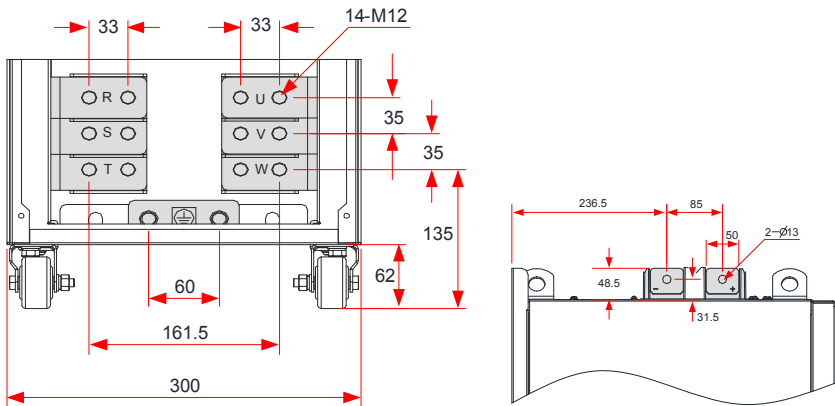

Figure 3-48 Dimensions of the main circuit terminals (CS710-4T200G-L/CS710-4T220G-L, without the side entry copper bar and output reactor)

Table 3-15 Recommended main circuit cables for CS710-4T200G(-L)/CS710-4T220G(-L)

AC Drive Model	Rated Input Current (A)	Power Input/ Output Cable (mm ²)	Lug Model	Ground Cable (mm ²)	Ground Cable Lug Model	Tightening Torque (N · m)
CS710-4T200G(-L)	365	2 x (3 x 95)	BC95-12	95	BC95-12	35.0
CS710-4T220G(-L)	410	2 x (3 x 120)	BC120-12	120	BC120-12	35.0

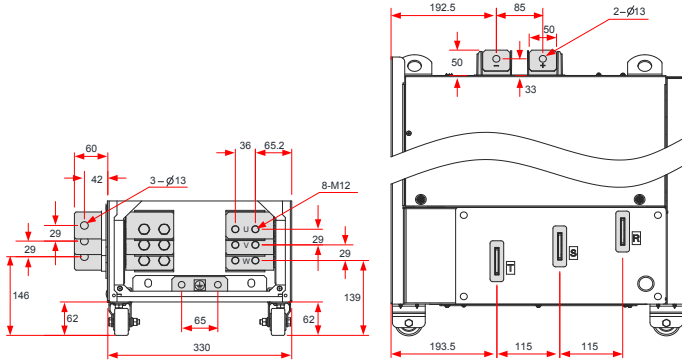

Figure 3-49 Dimensions of the main circuit terminals (CS710-4T250G/ CS710-4T280G, without the output reactor)

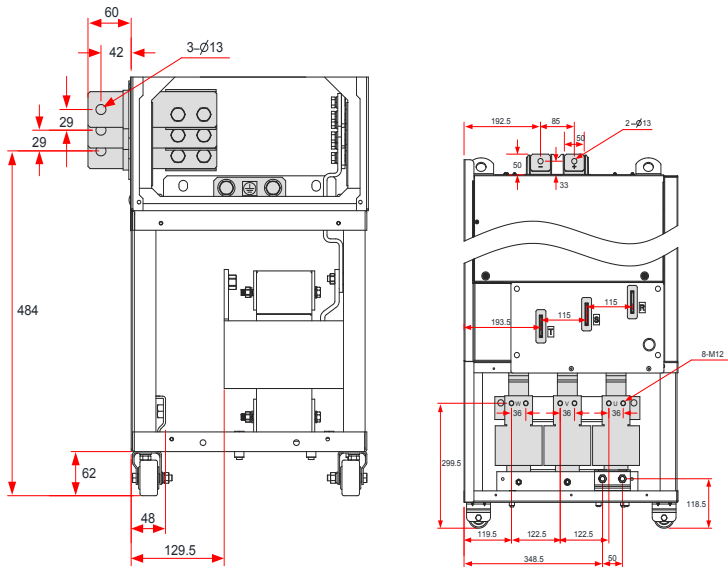

Figure 3-50 Dimensions of the main circuit terminals (CS710-4T250G-L/ CS710-4T280G-L, with the output reactor)

The side entry copper bar in the preceding figures can be removed if necessary. The following figure shows the main circuit terminal dimensions without the side entry copper bar.

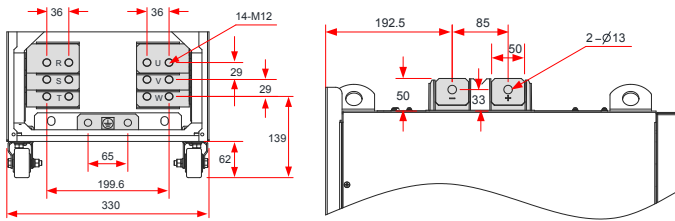

Figure 3-51 Dimensions of the main circuit terminals (CS710-4T250G/CS710-4T280G, without the side entry copper bar and output reactor)

Table 3-16 Recommended main circuit cables for CS710-4T250G(-L)/ CS710-4T280G(-L)

AC Drive Model	Rated Input Current (A)	Power Input/ Output Cable (mm ²)	Lug Model	Ground Cable (mm ²)	Ground Cable Lug Model	Tightening Torque (N·m)
CS710-4T250G(-L)	441	2 x (3 x 120)	BC120-12	120	BC120-12	35.0
CS710-4T280G(-L)	495	2 x (3 x 150)	BC150-12	150	BC150-12	35.0

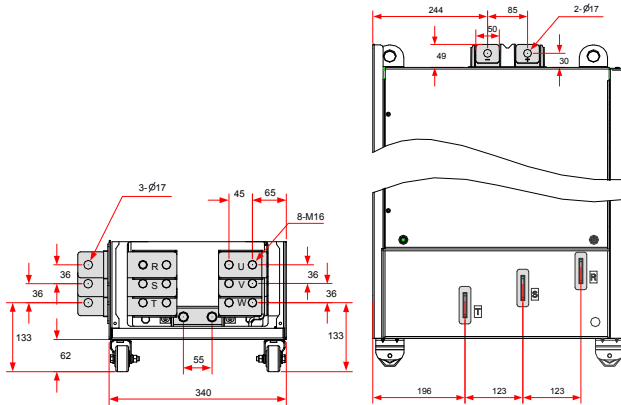

Figure 3-52 Dimensions of the main circuit terminals (CS710-4T315G to CS710-4T450G, without the output reactor)

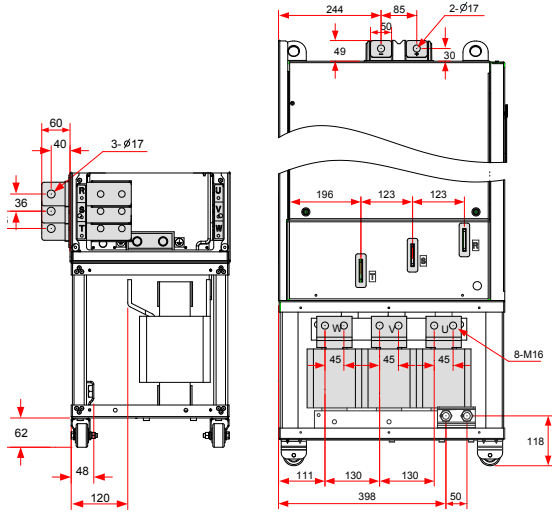

Figure 3-53 Dimensions of the main circuit terminals (CS710-4T315G-L to CS710-4T450G-L, with the output reactor)

The side entry copper bar in the preceding figures can be removed if necessary. The following figure shows the main circuit terminal dimensions without the side entry copper bar.

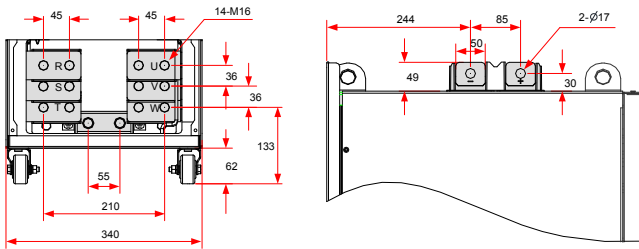

Figure 3-54 Dimensions of the main circuit terminals (CS710-4T315G to CS710-4T450G, without the side entry copper bar and output reactor)

Table 3-17 Recommended main circuit cables for CS710-4T315G(-L)/CS710-4T355G(-L)/CS710-4T450G(-L)

AC Drive Model	Rated Input Current (A)	Power Input/ Output Cable (mm ²)	Lug Model	Ground Cable (mm ²)	Ground Cable Lug Model	Tightening Torque (N·m)
CS710-4T315G(-L)	565	2 x (3 x 185)	BC185-16	185	BC185-16	85.0
CS710-4T355G(-L)	617	2 x (3 x 185)	BC185-16	185	BC185-16	85.0

AC Drive Model	Rated Input Current (A)	Power Input/ Output Cable (mm ²)	Lug Model	Ground Cable (mm ²)	Ground Cable Lug Model	Tightening Torque (N·m)
CS710-4T400G(-L)	687	2 x (3 x 240)	BC240-16	240	BC240-16	85.0
CS710-4T450G(-L)	782	2 x (3 x 240)	BC240-16	240	BC240-16	85.0

Recommended lugs are GTNR and BC series lugs manufactured by Suzhou Yuanli Metal Enterprise Co., Ltd.

Information about the recommended lugs (manufactured by Suzhou Yuanli Metal Enterprise Co., Ltd.)



GTNR Series



TNR Series



BC Series

**NOTE**

- ◆ For details about the selection of cable lugs, see "9.4.2 Modles and Dimensions of Cable Lugs."

3.2.4 Requirements on Main Circuit Wiring Tools

Take the terminal dimensions into consideration when wiring the main circuit terminals. Select suitable tools for secure wiring. The following table describes the wiring tools.

Table 3-18 Requirements on main circuit wiring tools (three-phase 380–480 V)

AC Drive Model	Main Circuit Terminal Fastener	Tool
CS710-4T0.4GB	M4 SEMS screw	Cross head screwdriver (slot 3#)
CS710-4T0.7GB		
CS710-4T1.1GB		
CS710-4T1.5GB		
CS710-4T2.2GB		
CS710-4T3.0GB		
CS710-4T3.7GB		
CS710-4T5.5GB		
CS710-4T7.5GB	M5 SEMS screw	Cross head screwdriver (slot 3#)
CS710-4T11GB		
CS710-4T15GB		

3 Installation and Wiring

AC Drive Model	Main Circuit Terminal Fastener	Tool
CS710-4T18.5GB(-T)	M6 SEMS screw	Cross head screwdriver (slot 3#)
CS710-4T22GB(-T)		
CS710-4T30GB		
CS710-4T37GB		
CS710-4T45GB	M8 nut, spring washer, flat washer	Socket wrench (socket 13#)
CS710-4T55GB		
CS710-4T75GB	M12 nut, spring washer, flat washer	Socket wrench (socket 19#), socket wrench extension bar (150 mm)
CS710-4T90G		
CS710-4T110G		
CS710-4T132G		
CS710-4T160G		
CS710-4T200G(-L)	M12 bolt, spring washer, flat washer	Socket wrench (socket 19#), socket wrench extension bar (250 mm)
CS710-4T220G(-L)		
CS710-4T250G(-L)		
CS710-4T280G(-L)		
CS710-4T315G(-L)	M16 nut, spring washer, flat washer	Socket wrench (socket 24#), socket wrench extension bar (250 mm)
CS710-4T355G(-L)		
CS710-4T400G(-L)		
CS710-4T450G(-L)		

3.2.5 Control Board

If you need to connect any jumper, PG card, or extension card during control circuit wiring, remove the cover of the AC drive first. The following figure shows locations of the control board, jumpers, and extension cards.

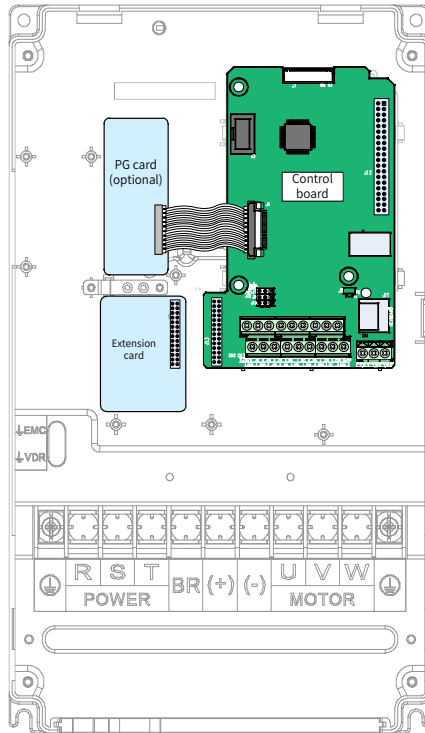

Figure 3-55 Installation position of the CS710 AC drive control board

■ Control circuit terminal arrangement

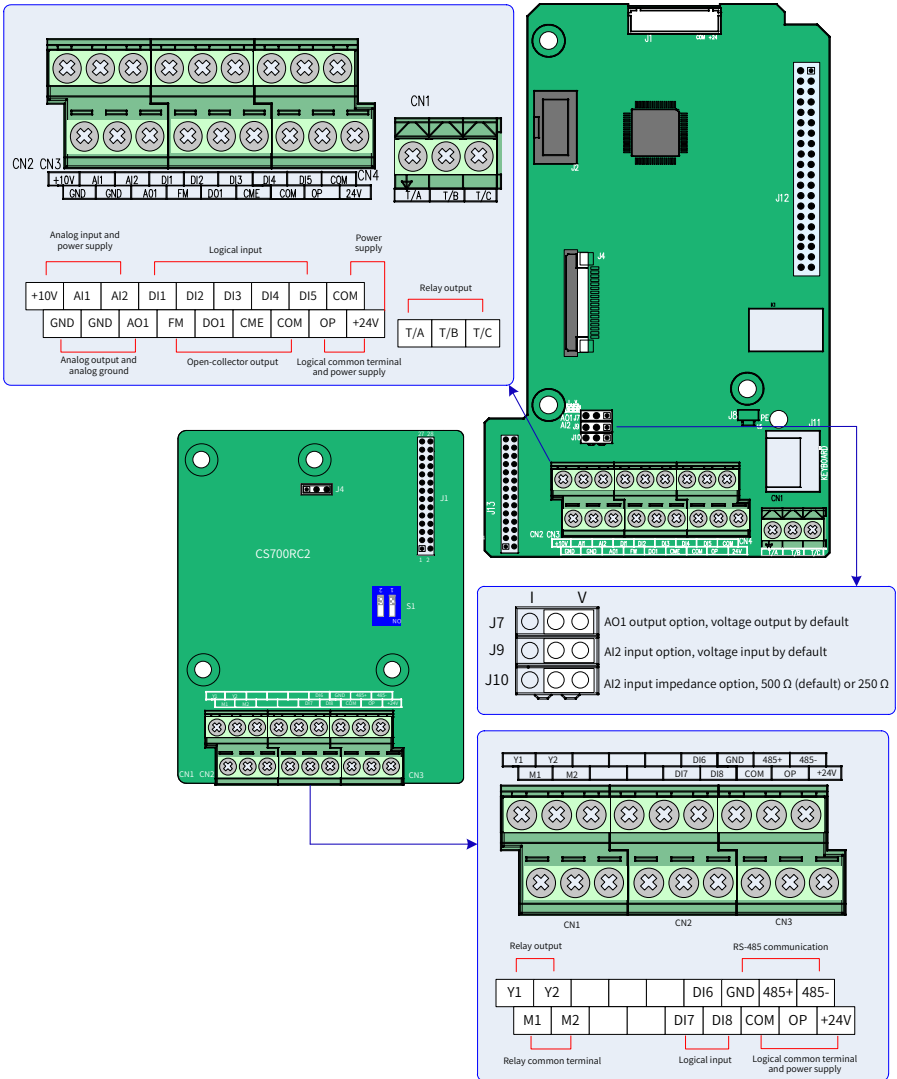

Figure 3-56 Control circuit terminal arrangement



◆ CS700IO1 is the standard configuration for AC drives of 11 kW and below, and CS700RC2 is the standard configuration for AC drives of 15 kW and above.

Table 3-19 Functions of control circuit terminals

Type	Identifier	Terminal Name	Description
Power supply	+10V-GND	+10 V power supply	Provides +10 V power supply to an external device. Max. output current: 10 mA Generally used to supply an external potentiometer of 1 to 5 k Ω
	+24V-COM	+24V power supply	Provides +24 V power supply to an external device. Generally used to supply the DI/DO terminals and external sensors. Max. output current: 200 mA ^[1]
	OP	Input terminal for external power supply	Connected to +24 V by default. When DI1 to DI5 need to be driven by external signals, OP must be disconnected from + 24 V and connected to an external power supply.
Analog inputs	AI1-GND	Analog input 1	Input voltage range: 0–10 V DC Input impedance: 22 k Ω
	AI2-GND	Analog input 2	Either a voltage or current input, determined by jumper J9 Input voltage range: 0–10 V DC Input current range: 0–20 mA Input impedance: 22 k Ω (voltage input), 500 Ω or 250 Ω (current input) determined by J10 ^[2]
Digital outputs	DI1- OP	Digital input 1	Isolated by optocoupler, compatible with dual-polarity inputs Input impedance: 1.39 k Ω Input voltage range: 9–30 V
	DI2- OP	Digital input 2	
	DI3- OP	Digital input 3	
	DI4- OP	Digital input 4	
	DI5- OP	Digital input 5	
	DI6- OP	Digital input 5	
	DI7- OP	Digital input 6	
Analog outputs	AO1-GND	Analog output 1	Either a voltage or current output, determined by jumper J7 Output voltage range: 0–10 V Output current range: 0–20 mA
	DO1-CME	Digital output 1	Isolated by optocoupler, dual-polarity open-collector output Output voltage range: 0–24 V Output current range: 0–50 mA Note that CME and COM are internally insulated, but are short connected externally by a jumper. In this case, DO1 is driven by +24 V by default. Remove the jumper link if you need to apply external power to DO1.
FM-CME	Digital output 2		

3 Installation and Wiring

Type	Identifier	Terminal Name	Description
Relay outputs	T/A-T/B	Normally-closed terminal 1	Contact driving capacity: 250 V AC, 3 A, COSØ = 0.4 30 V DC, 1 A
	T/A-T/C	Normally-open terminal 1	
	Y1-M1	Normally-open terminal 2	
	Y2-M2	Normally-open terminal 3	
Auxiliary interfaces	J13	Extension card interface	28-pin connector for optional cards (I/O extension card, PLC card, and various bus cards)
	J4	PG card interface	Options: open-collector, differential, and resolver
	J11	Operating panel interface	Connected to an external operating panel
Jumpers ^[3]	J7	AO1 output option	To select voltage or current output, voltage output by default
	J9	AI2 input option	To select voltage or current output, voltage input by default
	J10	AI2 input Impedance option	To select 500 Ω or 250 Ω input, 500 Ω input by default

[1] When the ambient environment is above 23°C, the output current must be de-rated by 1.8 mA per 1°C temperature rise. The maximum output current is 170 mA at 40°C. When OP is connected to 24 V, the current of the DI shall also be considered.

[2] Select 500 Ω or 250 Ω input impedance according to the load capacity of the signal source. For example, if 500 Ω is selected, the maximum output voltage of the signal source must not be smaller than 10 V so that AI2 can measure 20 mA current.

[3] Positions of jumpers J7, J9, and J10 on the control board are shown in the control circuit terminal arrangement diagram.

Table 3-20 Parameter settings for standard extension cards on the CS710 series AC drives

Function	Parameter setting
Models of 15 W and above (CS700RC2)	
Y1 relay	b3.20 is used to control the output of the Y1 relay. Set the thousands digit to 1 (indicating digital output) and use it the same way as other digital output points.
Y2 relay	b3.17 is used to control the output of the Y2 relay. Use it the same way as other digital output points.
DI6 input point	b3.06 is used to select the input function of the DI6 input point. Use it the same way as other digital input points.
DI7 input point	b3.07 is used to select the input function of the DI7 input point. Use it the same way as other digital input points.
DI8 input point	b3.08 is used to select the input function of the DI8 input point. Use it the same way as other digital input points.
Models of 11 kW and below (CS700IO1)	
PA-PC	b3.20 is used to control the output of the PA-PC. Set the thousands digit to 1 (indicating digital output) and use it the same way as other digital output points.
DI6 input point	b3.06 is used to select the input function of the DI6 input point. Use it the same way as other digital input points.
DI7 input point	b3.07 is used to select the input function of the DI7 input point. Use it the same way as other digital input points.

3.2.6 Control Circuit Terminal Wiring

■ Control circuit cable selection

All control wirings must be shielded. For different analog signals, use independent shielded cables and do not use the same shield. For digital signals, the shielded twisted pair (STP) cable is recommended.

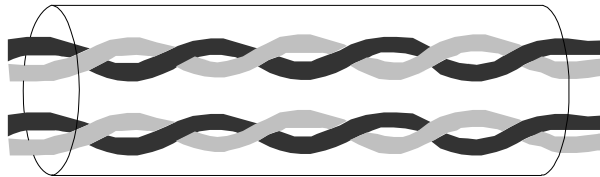

Figure 3-58 STP cable

■ Cabling requirements

Motor cables must be segregated from control wiring.

Do not run motor cables, power input cables and control wirings in the same duct to avoid electromagnetic interference caused by coupling of these cables.

If control wiring must run across the power cable, ensure they are arranged at an angle of 90°.

The recommended cabling diagram is as follows.

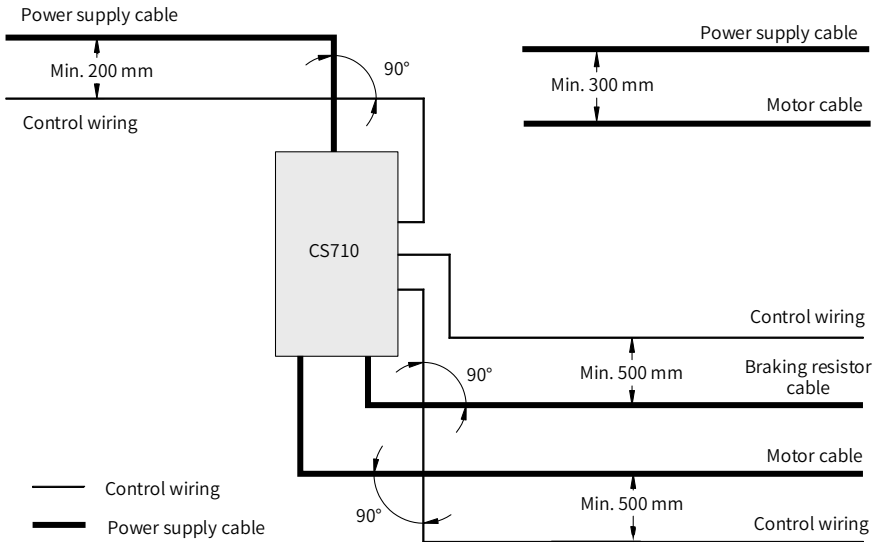

Figure 3-59 Cabling

■ Wiring of AI1

Analog signals at low levels can suffer from effects of external interference. To reduce this effect, use shielded cables shorter than 20 m to carry analog signals, as shown in Figure 3-60. In applications where analog signals suffer from effects of severe external interference, install a filter capacitor or a ferrite magnetic core at the source of analog signals, as shown in Figure 3-62.

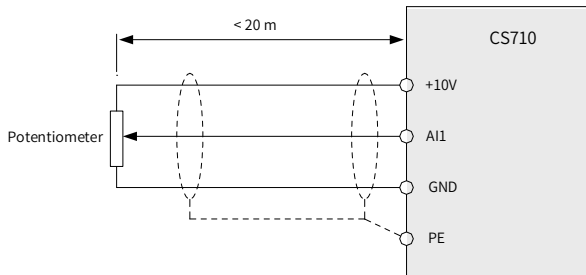

Figure 3-60 Wiring of AI1

The drain wire of the shield must be connected to the PE terminal on the AC drive.

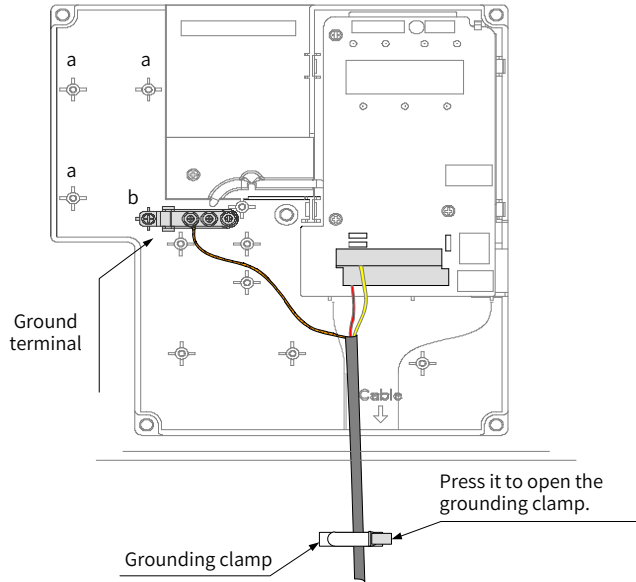

Figure 3-61 Connecting shield to the PE terminal of the AC drive

■ Wiring of AI2

When you select voltage input through AI2, use the same wiring method as AI1. When you select current input through AI2, set jumper J9 to the I side.

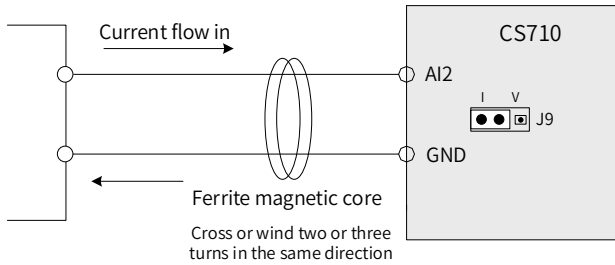

Figure 3-62 Wiring of AI2

■ Wiring of DI1 to DI5

1) SINK wiring

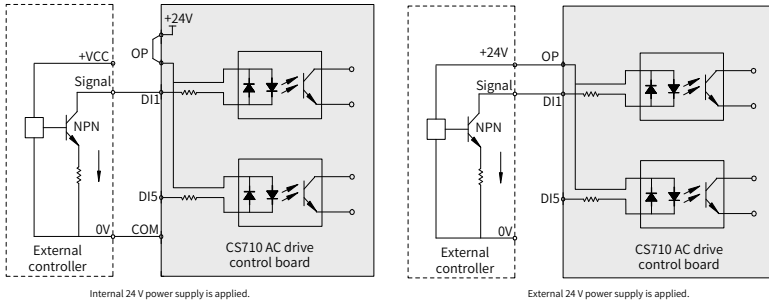

Figure 3-63 SINK wiring

Applying internal 24 V power supply is the most commonly used wiring mode. In this mode, short terminals +24V and OP and connect COM to 0V of the external controller.

To apply external 24V power supply, remove the jumper between terminals +24V and OP. Connect positive side of external power 24V to OP, and external power 0V to corresponding DI terminal through the contact on the external controller.

CAUTION

In SINK mode, do not connect DI terminals of different AC drives in parallel. Otherwise, a digital input fault may occur. If you need to connect different AC drives in parallel, connect a diode (connecting the anode to the DI) in series at DI terminals, as shown in Figure 3-64. The diode characteristics must satisfy the following requirements:

- ◆ IF: > 40 mA
- ◆ VR: > 40 V

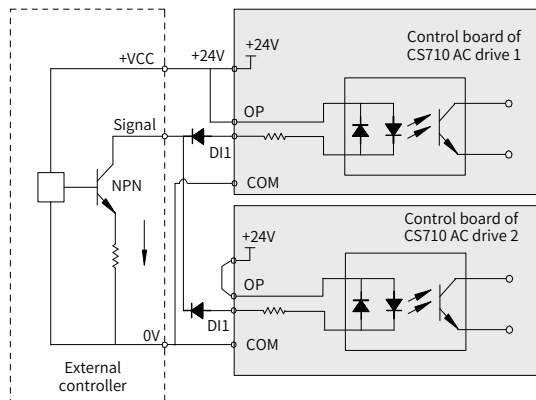

Figure 3-64 Parallel connection of DI terminals of multiple AC drives in SINK mode

2) SOURCE wiring

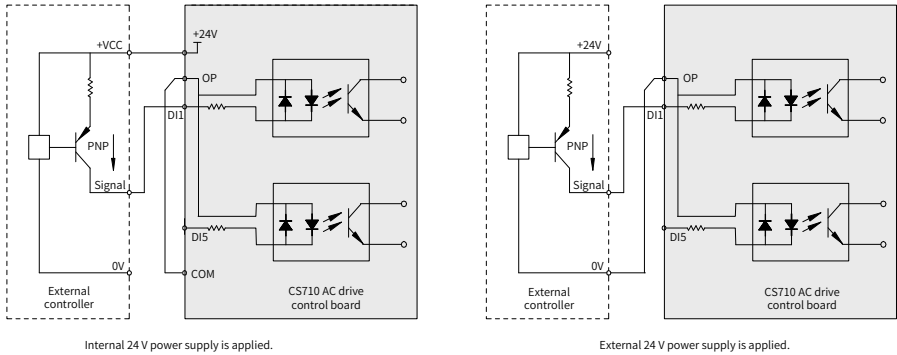

Figure 3-65 Wiring in SOURCE mode

If you intend to use the internal 24 V power supply of the AC drive, remove the jumper between terminals +24V and OP. Connect +24V to the common port of the external controller, and connect terminal OP to terminal COM.

If you intend to use an external power supply, remove the jumper between terminals +24V and OP. Connect external power 0V to terminal OP, and the positive side of external power +24V to corresponding DI terminal through the contact on the external controller.

3) Wiring of DI5 (high-speed pulse input)

As a high-speed pulse input terminal, DI5 allows the maximum frequency input of 100 kHz.

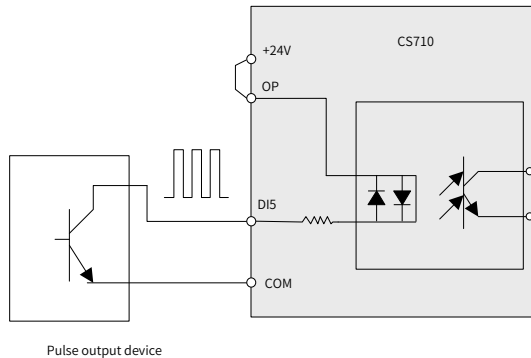

Figure 3-66 High-speed pulse input

■ Wiring of DO

When the DO terminal is required to drive the relay, install an absorption diode across the relay coil. This diode prevents inductive switching transients causing damage to the DC 24V power supply. The absorption diode must have a forward current rating of 50 mA.

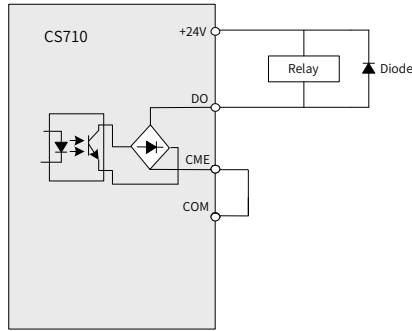

Figure 3-67 Wiring of DO

CAUTION

- ◆ As shown in Figure 3-67, install the absorption diode with correct polarity to prevent damage to the 24 VDC power supply.
- ◆ CME and COM are internally insulated, but are shorted externally by a jumper before delivery. In this case, DO1 is driven by +24 V by default. Remove the jumper if you need to drive DO1 by an external power supply.

■ Wiring of high-speed DO terminal FM

When the FM terminal is used for FMP continuous pulse output, the maximum output frequency is 100 kHz.

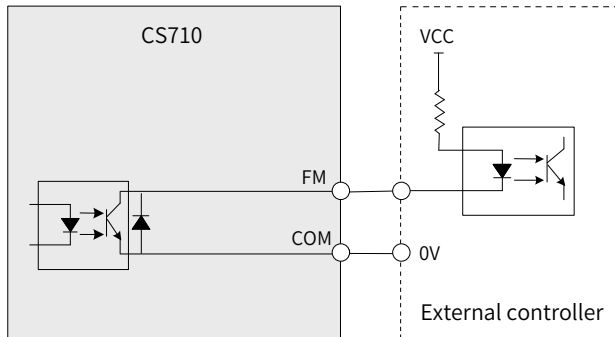

Figure 3-68 Wiring of high-speed DO terminal FM

■ Wiring of the relay output terminal

To smooth peak voltage that results from cutting off power to inductive load (relay, contactor and motor), use a voltage dependent resistor (VDR) at the relay contact and add an absorbing circuit to the inductive load, such as a VDR, RC absorbing circuit or diode.

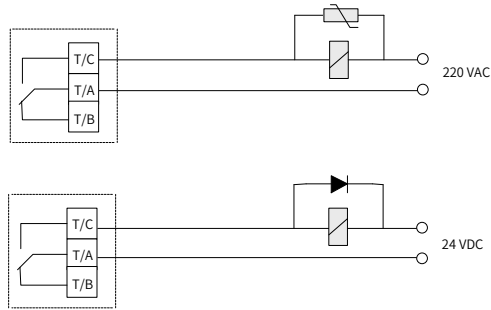

Figure 3-69 Wiring of the relay terminal

3.2.7 Wire Size and Torque Specifications of the Control Circuit

■ Ferrule-type terminal

Use a ferrule-type terminal with insulated sleeves.

If the single wire or twisted wire is used, the wire core must be exposed for 6 mm.

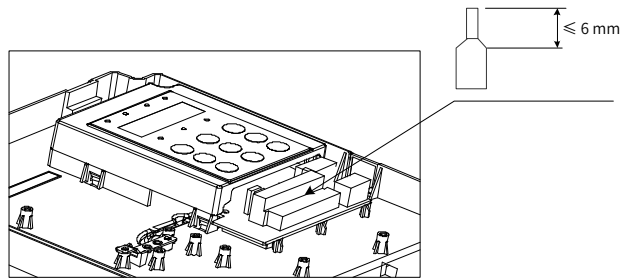

Figure 3-70 Ferrule dimensions

Table 3-21 Wire size and torque specification

Control Circuit Terminal Block	Single Wire (AWG/mm ²)	Twisted Wire (AWG/mm ²)	Tightening Torque (N·m)
		0.2 to 0.75 (AWG24 to 18)	

3.2.8 Wiring of the External Operating Panel

To connect an external operating panel, connect the cable to the RJ45 interface of the AC drive and run the cable through either side of the AC drive, as shown below.

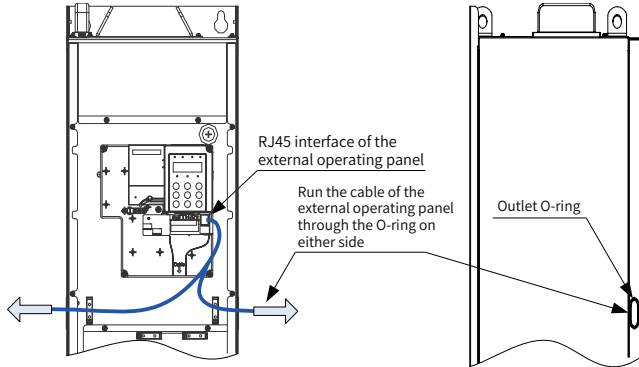

Figure 3-71 Wiring of the external operating panel



NOTE

◆ For details about the installation dimensions and usage of the external operating panel, see ["4.2 LED Operating Panel"](#) and ["4.3 Viewing and Modifying Parameters"](#).

3.2.9 Wiring Checklist

Table 3-22 Wiring checklist

No.	Item	Checked
1	Check that you receive a correct model.	
2	Ensure correct peripheral devices (braking resistor, braking unit, AC reactor, filter and breaker) are used.	
3	Check that the models of optional cards are correct.	
4	Check that mounting method and location meet the requirements.	
5	Check that the power supply input is within 323 V to 528 V.	
6	Check that the rated motor voltage matches the AC drive output specification.	
7	Connect power supply to the R, S, T terminals of the AC drive properly.	
8	Connect motor cables to the U, V, W terminals of the AC drive properly.	
9	Check that the cable diameter of the main circuit complies with specifications.	
10	Check that heat shrink tubes are added to lug copper tubes and cable core parts of the main circuit and ensure the heat shrink tube completely covers the cable conductor part.	
11	Decrease F0-15 (Carrier frequency) if the motor output cable exceeds 50 m.	
12	Ground the AC drive properly.	
13	Check that output terminals and control signal terminals are connected securely and reliably.	

No.	Item	Checked
14	When using the braking resistor and braking unit, check whether they are wired properly and whether their resistance values are proper.	
15	Use shielded twisted pair (STP) cables as signal lines.	
16	Connect optional cards correctly.	
17	Segregate control wiring from power supply cables of the main circuit.	

4 Panel Operations

4.1 Introduction

A CS710 series AC drive has a built-in LED operating panel, which allows you to set parameters and monitor/control system status.

A remote/external LED (MD32NKE1) or LCD operating panel is available as an option. The LED operating panel allows you to modify and view parameters. For its appearance and use, see "[4.2 LED Operating Panel](#)". The LCD operating panel allows you to copy, upload, and download parameters and displays parameters.

4.2 LED Operating Panel

The LED operating panel allows you to set and modify parameters, monitor system status, and start or stop the AC drive. The following figure shows the appearance of the operating panel and its keys.

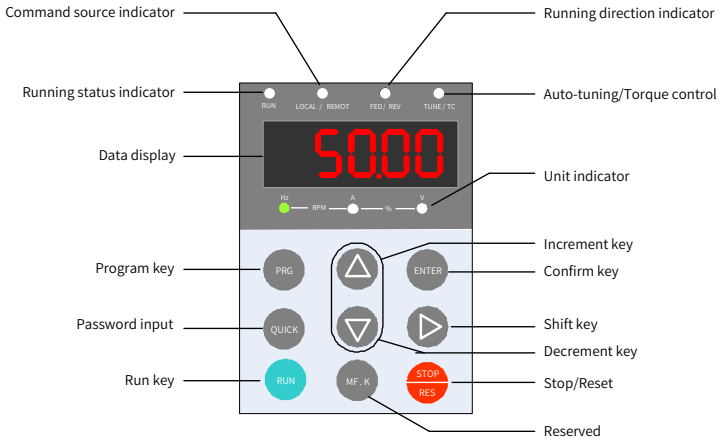

Figure 4-1 LED operating panel

4.2.1 Function Indicators















In the following table,  indicates that an indicator is on,  indicates that an indicator is off, and  indicates that an indicator is blinking.

Table 4-1 Indicators on the operating panel

	State	Indication
RUN Running status indicator	 RUN	Off: stopped
	 RUN	On: running ^[1]
LOCAL/REMOT Running command indicator	 LOCAL/REMOT	Off: under operating panel control
	 LOCAL/REMOT	On: under terminal control
	 LOCAL/REMOT	Blinking: under serial communication control
FWD/REV Forward and reverse rotation indicator	 FED/REV	Off: forward motor rotation
	 FED/REV	On: reverse motor rotation
TUNE/TC Tuning, torque control and fault indicator	 TUNE/TC	Off: running normally
	 TUNE/TC	On: torque control mode
	 TUNE/TC	Slow blinking: auto-tuning state (once per second)
	 TUNE/TC	Quick blinking: faulty (four times per second)
 Hz — RPM —  A — % —  V	Hz for frequency	
 Hz — RPM —  A — % —  V	A for current	
 Hz — RPM —  A — % —  V	V for voltage	
 Hz — RPM —  A — % —  V	RPM for motor speed	
 Hz — RPM —  A — % —  V	Percentage	

[1] The RUN indicators turns on when the AC drive is in the DC injection braking, pre-excitation, and magnetic flux state.

4.2.2 LED Display

The five-digit LED data display shows the frequency reference, output frequency, monitoring information, and fault code.

Table 4-2 Indication of the LED display

LED Display	Indication	LED Display	Indication	LED Display	Indication	LED Display	Indication
0	0	6	6	℃	°C	N	N
1	1	7	7.	c	c	P	P
2	2	8	8	D	D	R	R
3	3	9	9	E	E	T	T
4	4	A	A	F	F	U	U
5	5, S	B	B	L	L	u	u

The 5-digit LED display shows monitoring data, fault codes, and parameters. Figure 4-2 shows an example.

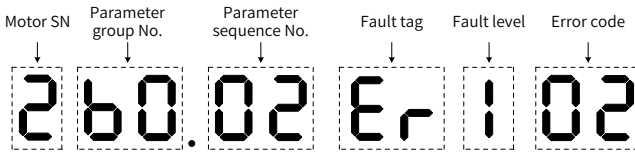

Figure 4-2 Example of the LED display









NOTE

◆ If DI is not set to motor switching (input functions 27 and 28), the LED display does not show the sequence number of the currently connected motor.

4.2.3 Keys on the LED Operating Panel

Table 4-3 Function of keys on the LED operating panel

Key	Key Name	Function
	Programming	Enter or exit level-1 menu.
	Confirm	Enter each level of menu interface and confirm the displayed parameter setting.
	Increment	Increase the displayed value when editing a parameter value.

Key	Key Name	Function
	Decrement	Decrease the displayed value when editing a parameter value.
	Shift	Select the displayed parameter in the STOP or RUNNING status. Select the digit to be changed when modifying a parameter.
	RUN	Start the AC drive when using the operating panel control mode.
	Stop/Reset	Stop the AC drive when using the operating panel control mode. Reset the AC drive when it is in the FAULT state.
	Reserved	Function reserved.
	Quick	Quickly enter the password input interface.

4.3 Viewing and Modifying Parameters



The operating panel of a CS710 AC drive provides three windows: status display → parameter numbers → parameter setting. When you enter a menu and see the display blinking, you can press the ,  or  key to switch between windows.

Figure 4-3 shows the operation flowchart.

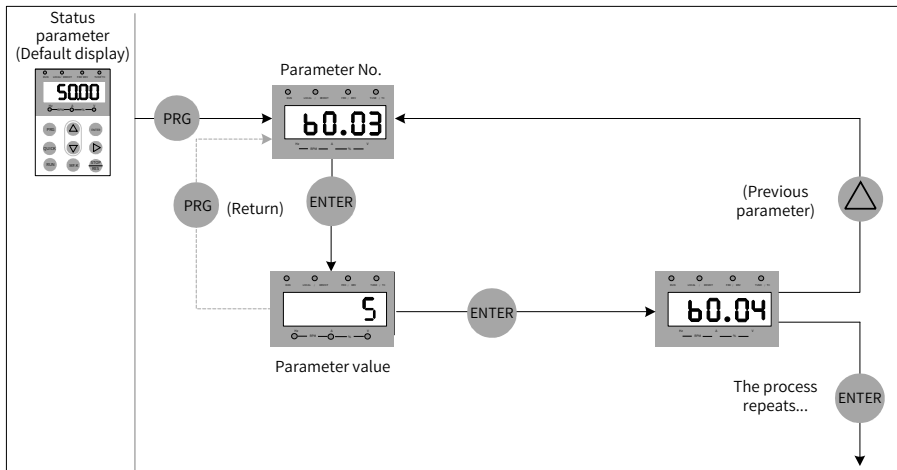

Figure 4-3 Switching between different operation windows

Example: Change the value of parameter b1.02 from 10.00 Hz to 15.00 Hz.

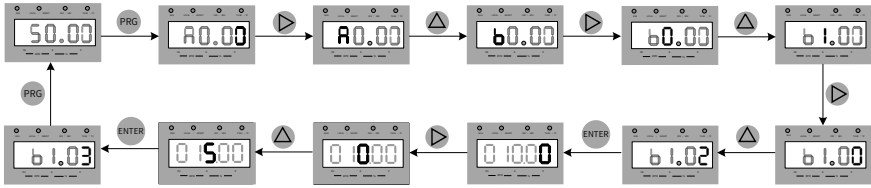

Figure 4-4 Changing the value of a parameter

In the parameter setting window, if a parameter has no blinking digit, the parameter cannot be modified. Possible causes include:

- 1) The parameter is read-only. For example, it indicates the monitoring information and running status.
- 2) The parameter cannot be modified while the AC drive is running. You can modify it only after stopping the AC drive.

4.4 Parameter Structure

Table 4-4 Parameter structure

Parameter Group	Function Description	Description
Group A	Basic crane parameter group	Used to set motor parameters and basic information about the crane
Group b	AC drive function parameter group	Function parameters such as operation command, frequency command, speed curve, and brake time sequence
Group F	AC drive performance group	Core performance parameters of the AC drive
Group U	Monitoring parameter group	Basic monitoring parameters
Group E	Fault parameter group	Fault record display

4.5 Viewing Status Parameters

When the AC drive is in the stop or running state, you can view multiple status parameters by pressing the  key on the operating panel. In running state, you can view five parameters: frequency reference, output synchronizing frequency, output current, output voltage, and bus voltage. In stop state, you can view only the target frequency and bus voltage.

5 System Commissioning

This chapter describes basic commissioning operations for a trial run of a crane AC drive, including setting the frequency reference, and stopping and starting the AC drive.

5.1 Quick Commissioning Guide

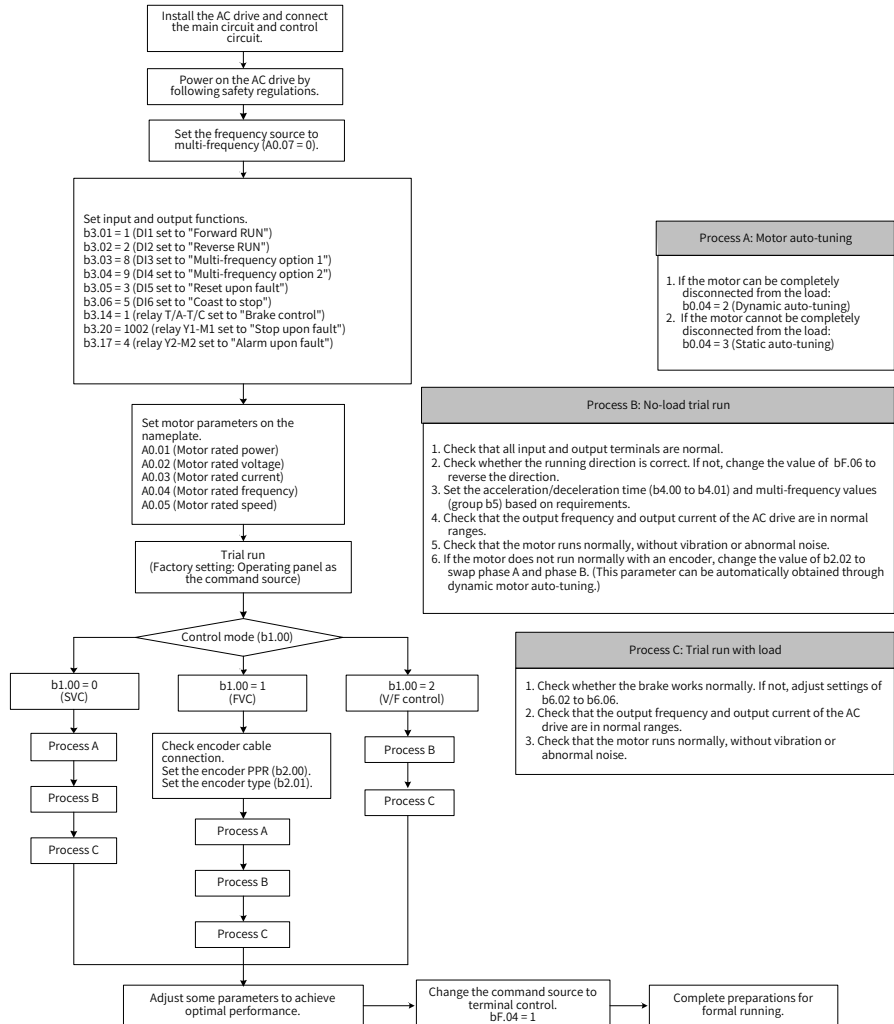

Figure 5-1 Quick commissioning steps



5.2 Precautions Before Power-on

Check the following items before powering on the AC drive.

Item	Requirement
Voltage	The input voltage is in the range of 380 to 480 VAC, 50/60 Hz.
	The input terminals R, S, and T are properly connected.
	The AC drive is connected to the motor properly.
Connection of AC drive output terminals and motor terminals	The AC drive output terminals U, V, and W are firmly connected to the motor terminals.
Connection of terminals in the control circuit	Terminals of the control circuit are firmly connected to other control devices.
Status of control terminals	All terminals of the control circuit are in OFF position (the AC drive is not running).
Load	The motor is not idle and is connected to the mechanical system.

5.3 Status Display After Power-on

The following table describes the display on the operating panel after the AC drive is powered on.

State	Display	Description
Normal		The default value 8.00 Hz is displayed.
Faulty		The AC drive stops and the error type is displayed.

5.4 Restoring Factory Settings

The CS710 series defines three levels of menus for parameters. Each menu allows you to restore factory settings (except for certain parameters) and check user-defined settings (only non-default values displayed on the operating panel).

Menu	Parameter	Function Description	Remarks
Level-1 menu	AF.01	Restore factory settings in the level-1 menu.	Some parameters cannot be restored to the factory settings. For details, see the description of AF.01.
	AF.02	Display user-defined parameter settings in the level-1 menu.	Only non-default parameter settings in the level-1 menu are displayed.

Menu	Parameter	Function Description	Remarks
Level-2 menu	bF.01	Restore factory settings in the level-2 menu	You can restore factory settings of parameters in the level-2 menu or in the level-1 and level-2 menus simultaneously. Some parameters cannot be restored to factory settings. For details, see the description of bF.01.
	bF.02	Display user-defined parameter settings in the level-2 menu	Only non-default parameter settings in the level-2 menu are displayed.
	bF.03	Clear historical record	This parameter is used to clear parameters stored upon a power failure of the AC drive, including the monitoring parameters in group U1 and fault record parameters. For the usage of bF.03, see its description.
Level-3 menu	FF.10	Restore factory settings in the level-3 menu	You can restore factory settings of parameters in the level-3 menu or all parameters. Some parameters cannot be restored to factory settings. For details, see the description of FF.10.
	FF.11	Display user-defined parameter settings in the level-3 menu	Only non-default parameter settings in the level-3 menu are displayed.

5.5 Motor Control Modes

Parameter	Description	Scenario
b1.00: Motor control mode	0: Sensorless vector control (SVC)	SVC is the open-loop vector control mode applicable to common hoisting.
	1: Flux vector control (FVC)	FVC is the closed-loop vector control mode. The motor must have an encoder, and the AC drive must have a PG card of the same type as the encoder. This control mode is applicable to scenarios requiring high precision speed or torque control.
	2: V/F control	This control mode is applicable to scenarios that do not require high load capacity or connection of multiple motors driven by one AC drive.

5.6 Start and Stop Commands

There are three sources of start/stop command for the AC drive: operating panel control, terminal control, and communication control. You can select the command source using bF.04.

bF.04	Command source selection		0
	Value range	0	Operating panel control (indicator off)
		1	Terminal control (indicator on)
	2	Communication control (indicator blinking)	

You can use bF.04 to select the input channel of AC drive control commands, including start, stop, forward, reverse, and jog.

0: Operating panel control (LOCAL/REMOT indicator off)

The commands are given by pressing the RUN and STOP/RES keys on the operating panel.

1: Terminal control (LOCAL/REMOT indicator on)

The commands are given by using multi-functional input terminals.

2: Serial communication control (LOCAL/REMOT indicator blinking)

5.6.1 Operating Panel Control

Set bF.04 to 0 to select the operating panel as the input channel for the AC drive control commands. After you press RUN, the AC drive starts to run (the RUN indicator is on). After you press STOP while the AC drive is running, the AC drive stops running (the RUN indicator is off).

5.6.2 Terminal Control (DI)

This control mode is applicable to scenarios where the DIP switch or electromagnetic button is used to start or stop the application system or scenarios where the dry contact signal is used to start or stop the AC drive.

The CS710 series AC drive can be controlled using terminals. Parameters b3.01 to b3.12 determine the functions of the AC drive control signals. For details, see the description of these parameters.

Example 1: To use the DIP switch to start and stop the AC drive, and allocate the forward rotation switch signal to DI1 and the reverse rotation switch signal to DI2, perform the settings according to the following figure.

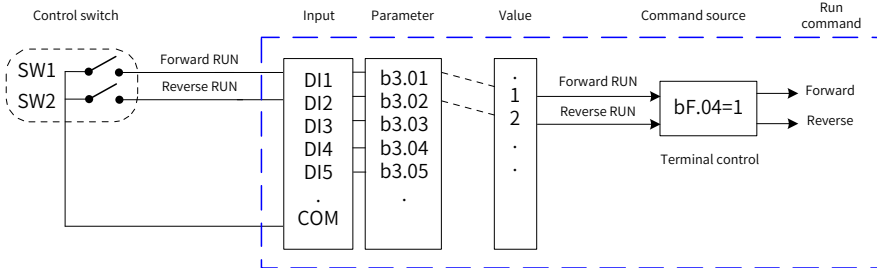

Figure 5-2 Example of AC drive control using terminals

In the control mode set in Figure 5-2, when SW1 is ON, the AC drive receives the command

forward rotation; when SW1 is OFF, the AC drive stops. When SW2 is ON, the AC drive receives the command reverse running; when SW2 is OFF, the AC drive stops. When SW1 and SW2 are both ON, the AC drive reports error 44# (both forward and reverse rotation commands are active).

In the operating panel control mode, after you press RUN, the motor is driven by the AC drive to rotate in the forward rotation. If the rotating direction is reverse to the direction required by the equipment, power off the AC drive and swap any two of the output UVW cables (wait until the main capacitor of the AC drive is completely discharged). You can also change the rotating direction of the motor by setting bF.06 to 1.

5.6.3 Serial Communication Control

AC drive control through communication with a host controller becomes more and more widely used. After you install an RS-485 interface card in the AC drive and select serial communication as the source of AC drive control commands (bF.04 = 2), you can control the AC drive from a host controller. The following figure shows how to set the parameter for this control mode.

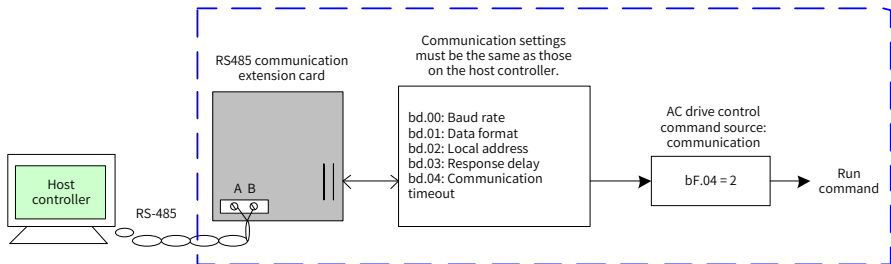

Figure 5-3 Example of AC drive control through communication with a host controller

When the communication timeout interval (bd.04) is set to a non-zero value, automatic drive stop upon communication timeout is enabled. This function prevents uncontrollable AC drive running due to faults of the communication cable or the host controller. This function can be enabled in some application scenarios.

5.7 Start and Stop Settings

5.7.1 Start Mode

The CS710 series AC drive uses the direct start mode and has a predefined crane brake control time sequence (see the description of the b6 group parameters).

5.7.2 Stop Mode

The CS710 series AC drive supports two stop modes: coast to stop and decelerate to stop, which can be set using b4.03. The default mode is decelerate to stop (b4.03 = 0).

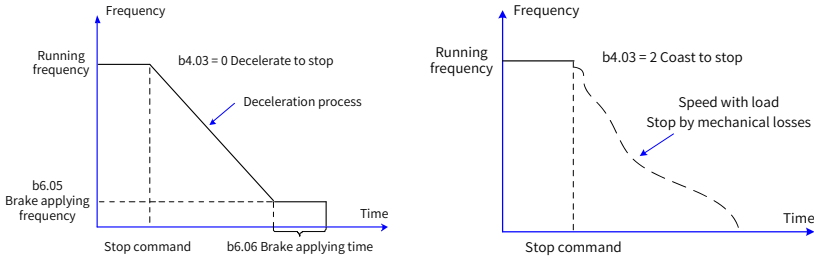

Figure 5-4 Stop modes

5.8 Frequency Reference Selection

The CS710 series AC drive supports six sources of frequency reference, namely, multi-reference, analog input AI1, analog input AI2, acceleration/deceleration, and serial communication. You can select the sources using A0.07 and b3.00. For details, see the description of the two parameters.

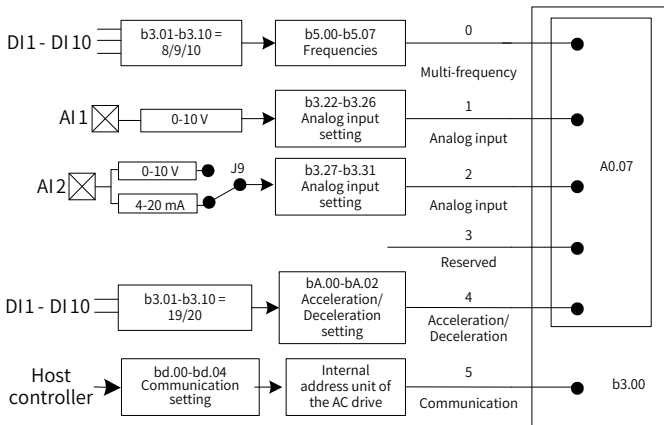

Figure 5-5 Selecting the source of frequency reference

Figure 5-5 describes the parameters for setting the sources of frequency reference. See the description of specific parameters when setting them.

5.8.1 Setting the Multi-reference Mode

You can select the multi-reference mode for applications that use only several frequency values and do not need to adjust the frequency reference of the AC drive. On a CS710 series AC drive, you can set a maximum of eight frequency ranges using a maximum of three DI input functions. To specify multi-frequency command input terminals, set the parameters corresponding to the DI terminals to integer values in the range of 8-10. You can set the multi-frequency values according to the multi-frequency table of b5 group parameters. Set the frequency source to multi-frequency, as shown in the following figure.

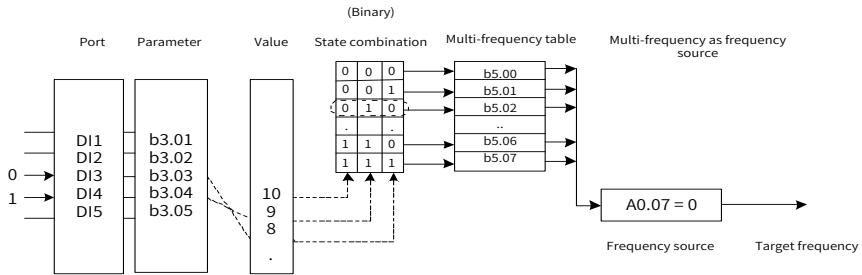

Figure 5-6 Setting the multi-reference mode

In the preceding figure, DI3 and DI4 are used as the multi-frequency input terminals, each of which has a binary value of 0 or 1. Each state combination is a 3-bit binary value. You can select multiple state combinations to select up to eight multiple frequencies. When (DI3, DI4) = (0, 1), the binary value is (010) and therefore the state combination value is 2. In this case, the frequency value set by b5.02 is used. As the frequency source is multi-frequency, the value of b5.02 determines the target frequency.

For a CS710 AC drive, you can select a maximum of three DI terminals (or fewer, as shown in this example) as multi-frequency command input terminals.

5.8.2 Using Analog Input to Set Frequency Reference

Figure 5-7 shows how to use a potentiometer to adjust the frequency reference of the AC drive. When the potentiometer is adjustable in the full range, the output frequency of the running AC drive can change between 0 and the maximum frequency value.

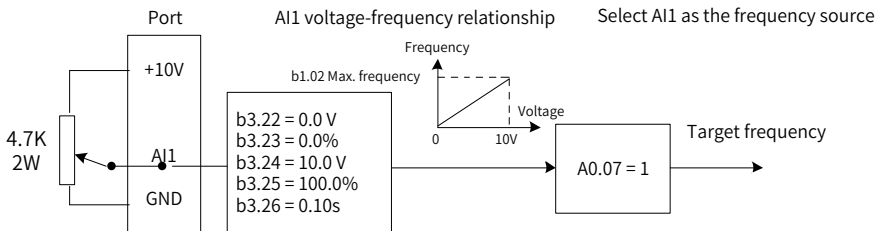

Figure 5-7 Using analog input to set frequency reference

5.9 Description of Terminals

5.9.1 DI Terminals

The internal hardware of DI terminals is configured with a 24 V DC power supply for detection. A DI terminal is used to send input signals to the AC drive after you short connect the DI terminal to the COM port of the AC drive.

You can also set the software filter time (b3.21) for input signals from DI terminals to improve the anti-interference capability of the AC drive.

Functions of the eight DI terminals can be selected using parameters b3.01 to b3.08. For details, see the description of parameters b3.01 to b3.08.

5.9.2 AI Terminals

The CS710 series AC drive supports two AI inputs, which are designated as AI1 and AI2 on the control board.

Terminal	Input Signal Specifications
AI1-GND	Receives a voltage signal of 0 to 10 VDC.
AI2-GND	Receives a voltage signal of 0 to 10 VDC when jumper J8 in the position marked "V" and receives a current signal of 4 to 20 mA when J8 is in the position marked "I".

The AI terminals can be used when external voltage or current signals are used to set the frequency reference and torque reference for the AC drive. The mapping between voltage or current values and the actual setting or feedback is defined by b3.22 to b3.31.

The sampled values of AI terminals can be obtained from parameters U0.12 and U0.13. The calculated values used for subsequent calculation inside the AC drive and are not open to users.

5.9.3 DO Terminals

The control board provides five digital output (DO) terminals: FM, DO1, T/A-T/B-T/C, Y1-M1, and Y2-M2. FM and DO1 are transistor outputs capable of driving a 24 VDC low-voltage circuit. T/A-T/B-T/C, Y1-M1, and Y2-M2 are relay outputs capable of driving a 250 VAC control circuit.

Terminal	Parameter	Output Specifications
FM-CME	b3.18	Transistor Drive capacity: 24 V DC, 50 mA
DO1-CME	b3.16	Transistor Drive capacity: 24 V DC, 50 mA
T/A-T/B-T/C	b3.14	Relay Drive capacity: 250 V AC, 3A
Y1-M1	b3.20	
Y2-M2	b3.17	

5.9.4 AO Terminals

The AC drive supports two analog output (AO) terminals. AO1 is on the control board, and AO2 is on an optional extension card.

Terminal	Input Signal Specifications
AO1-GND	Provides 0 to 10 VDC output voltage signal when J7 is in the position marked "V".
	Provides 0 to 20 mA output current signal when J7 is in the position marked "I".
AO2-GND	Located on an extension card and provides 0 to 10 VDC output signal.

AO1 and AO2 provide analog outputs to monitor AC drive parameters. The specific parameter attributes are set using b3.19 and b3.20.

The designated running parameters can be corrected before connected to the output. The correction characteristic is $Y = kX + b$, where X indicates the AC drive parameter, whereas k

and b can be set using b3.44 and b3.43. Figure 5-8 shows the correction characteristic curve of AO1.

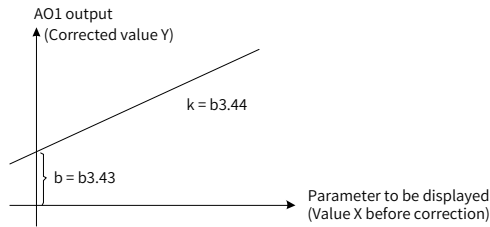

Figure 5-8 Output correction characteristic curve of AO1

5.9.5 PG Terminals

The closed-loop vector control mode ($b1.00 = 1$) can improve the speed accuracy performance of the AC drive. To use this mode, it is required to install an encoder on the motor shaft. Signals sent from the encoder are transmitted to the AC drive through the PG card (encoder signal interface card). The CS710 series AC drive supports one PG card with different signal features.

Three types of encoders can be used: differential encoder, resolver, and open-collector encoder.

The encoder parameters must be set based on the actual type of encoder used. The following example describes the setting of motor parameter group 1.

- 1) When a differential encoder is used, use b2.00 to set the pulses per revolution (PPR) and set b2.01 to 0 (ABZ incremental encoder).
- 2) When a resolver is used, set b2.01 to 2 (resolver).
- 3) When an open-collector or push-pull encoder is used, use b2.00 to set the PPR and set b2.01 to 0 (ABZ incremental encoder).
- 4) For details about the encoder usage, see ["10.3 Encoder Extension Cards"](#).

5.10 Auto-tuning

5.10.1 Motor Parameter Settings

When the AC drive runs in vector control mode ($b1.00 = 0$ or 1), accurate motor parameters are required to ensure satisfactory AC drive performance and running efficiency. This is one of major differences between the vector control mode and the V/F control mode ($b1.00 = 2$).

5.10.2 Motor Parameter Auto-tuning

The AC drive can obtain internal electrical parameters of the controlled motor in the following ways: dynamic auto-tuning, static auto-tuning, and manual input.

Auto-tuning Mode	Application	Auto-tuning Effect	Parameter Setting
Static auto-tuning (complete tuning)	Applicable to all scenarios	Good	b0.04 = 3
Dynamic auto-tuning without load (complete tuning)	Applicable to scenarios where the motor can be disconnected from the load	Good	b0.04 = 2
Static auto-tuning (incomplete tuning)	Applicable to scenarios where the motor cannot be disconnected from the load and dynamic auto-tuning is not allowed	Acceptable	b0.04 = 1

1) Procedure for implementing dynamic auto-tuning of motor parameters:

Step 1: If the motor can be disconnected from the load, cut off the power and disconnect the motor from the load so that the motor runs without load.

Step 2: Power on the AC drive, and then set the source of AC drive control commands (bF.04) to the operating panel.

Step 3: Enter motor nameplate parameters (A0.01 to A0.05) correctly. Set the following parameters based on the motor type:

Required Parameter Settings
A0.01: Rated power of the motor
A0.02: Rated voltage of the motor
A0.03: Rated current of the motor
A0.04: Rated frequency of the motor
A0.05: Rated rotating speed of the motor

Step 4: If the motor can be disconnected from the load, set b0.04 to 2 (Asynchronous motor dynamic auto-tuning), and then press ENTER to confirm the setting. The display on the operating panel is as follows:



Press RUN on the operating panel. The AC drive then drives the motor (acceleration time and deceleration time set by b4.06 and b4.07 respectively), and the RUN indicator turns on. When the preceding message disappears and normal parameter display is displayed on the operating panel, the auto-tuning process is finished.

After dynamic auto-tuning, the AC drive calculates the following motor parameters automatically:

Automatically updated parameters after auto-tuning
F0.00: Stator resistance of the asynchronous motor
F0.01: Rotor resistance of the asynchronous motor
F0.02: Leakage inductive reactance of the asynchronous motor
F0.03: Mutual inductive reactance of the asynchronous motor
F0.04: No-load current of the asynchronous motor

If the motor cannot be disconnected from the load, set b0.04 to 1 or 3 (recommended) to start static auto-tuning of motor parameters. Static auto-tuning mode 3 can obtain all motor parameters but takes a relatively long time.

2) One-key quick auto-tuning:

Hold down the QUICK key on the AC drive panel for 5s until the display shows TUNE, and then press RUN to start auto-tuning.

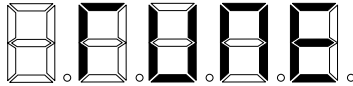

The quick auto-tuning function can be used when a new round of auto-tuning is required after motor parameters are set. Auto-tuning mode 3 (complete static auto-tuning) is used by default in this case. You do not need to disconnect the motor from the load or change the value of bF.04 or any other parameter.

5.11 Password Setting

The CS710 series AC drive provides user password protection.

Parameter	Function Description	Content
AF.00	Password for all function parameters	Password for groups A, b, E, U, and F
bF.00	Level-2 menu password	Password for groups b, E, U, and F
FF.00	Level-3 menu password	Password for group F

The password function is enabled when AF.00, bF.00, and FF.00 are set to non-zero values. In this case, the QUICK field on the operating panel displays -----. You can enter the menu only after entering the correct password. If you enter wrong passwords consecutively three times, the system is locked. To delete the password, power off and on the AC drive, enter the password, and then set AF.00, bF.00, and FF.00 to 0.

5.12 Application Examples

5.12.1 Hoisting System Braking

■ Brake time sequence overview

The CS710 software provides pre-defined brake time sequence control function. To use this function, set the function of an output terminal to output function 1 (brake control). The following figure shows the brake control time sequence.

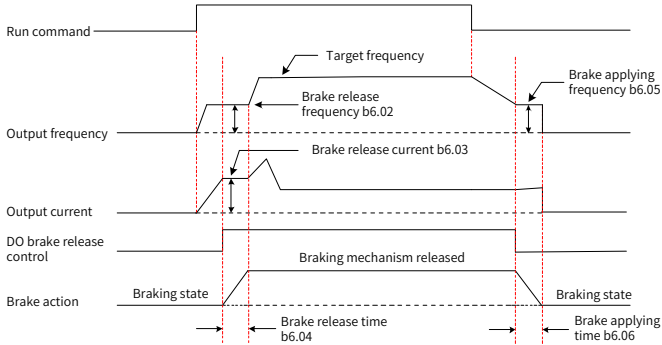

Figure 5-9 Typical control process of a hoisting system and code function setting

The brake is closed when it receives no power and is released after it is powered on. Actions of the brake are controlled with mechanical operations; therefore, there is a delay between brake signal output and braking state change. Set the brake applying time (b6.06) and brake release time (b6.04) based on the mechanical operation delay of the brake. Theoretically, the actual values of the two parameters should be slightly longer than the mechanical operation delay to prevent unintentional slip.

5.12.2 Safety Limit and Stop upon Faults

Figure 5-10 shows the circuit for safety limit and stop upon faults. A limit switch is installed on each end of the rail. When the mechanism touches a limit switch, the control cabinet automatically stops running of the AC drive in this direction. Running of the AC drive in the opposite direction is not affected, and you can press the reverse RUN switch to restore running of the equipment.

When a level-I fault occurs on the AC drive, relay terminal Y1-M1 on the extension I/O card sends a fault stop signal to trigger an action of contactor KM in the control cabinet. (For example, the contactor may cut off power to the running circuit. In this case, the equipment can resume normal running only after being reset).

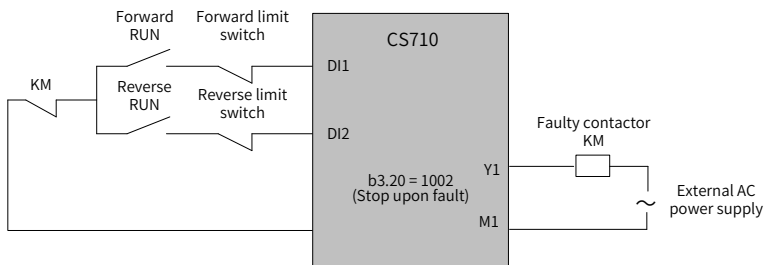

Figure 5-10 Circuit for safety limit and stop upon faults



NOTE

◆ The figure shows a commonly used connection of limit switches. You can change the connection based on your own requirements.

6 Parameter Table

The CS710 series AC drive has some manufacturer-reserved parameters, and their parameter numbers are not listed in the parameter tables. Therefore, the parameter numbers in the parameter tables are discontinuous. Do not modify the parameters that are not described in this user guide as doing so may cause errors in equipment operation.

You can modify the functional parameters only after the AC drive stops. Do not modify these parameters when the AC drive is running. The monitored parameters are displayed on the operating panel only for viewing and cannot be modified.

6.1 Level-1 Menu (Group A) Parameter Table

The level-1 menu contains motor parameters and basic feature parameters of the crane. Correct settings of level-1 menu parameters can ensure normal running of the motor driven by the AC drive. Parameters for improving functions of the AC drive need to be set in the level-2 menu.

Parameter No.	Parameter Name	Description	Value Range	Default
Group A0: Basic crane parameters				
A0.01	Rated power of the motor	This parameter sets the motor's rated power displayed on the motor nameplate.	0.4 to 1000.0 kW	Depending on drive model
A0.02	Rated voltage of the motor	This parameter sets the motor's rated voltage displayed on the motor nameplate.	0–2000 V	380 V
A0.03	Rated current of the motor	This parameter sets the motor's rated current displayed on the motor nameplate.	(≤ 55 kW) 0.01A to 655.35 A (> 55 kW) 0.1–6553.5 A	Depending on drive model
A0.04	Rated frequency of the motor	This parameter sets the motor's rated frequency displayed on the motor nameplate.	0.01 Hz to b1.02 (Max. frequency)	50.00 Hz
A0.05	Rated speed of the motor	This parameter sets the motor's rated rotating speed displayed on the motor nameplate.	0-3000 RPM	1400 RPM

6 Parameter Table

Parameter No.	Parameter Name	Description	Value Range	Default
A0.07	Frequency source option A	<p>This parameter is used together with b3.00 (frequency source option B) in the level-2 menu. A0.07 in the level-1 menu lists only four commonly used frequency sources, whereas b3.00 in the level-2 menu lists all frequency sources. If b3.00 is greater than 4, the frequency source specified by b3.00 takes effect. If b3.00 is smaller than or equal to 4, the frequency source specified by A0.07 takes effect.</p> <p>0: Multi-frequency The binary combinations of input function points 8, 9, 10 correspond to eight frequencies, which are set by b5.00 to b5.07. For details, see the description of group b5 parameters.</p> <p>1: AI1 AI1 supports only 0 to 10 V voltage input.</p> <p>2: AI2 AI2 supports 0 to 10 V voltage input or 4 to 20 mA current input, determined by jumper J9 on the control board. The analog input is directly proportional to the target frequency (linear proportion). The base frequency is b1.02 (maximum frequency).</p> <p>3: Reserved</p> <p>4: Acceleration/Deceleration This mode must be used together with input terminals that are assigned functions 19 and 20. For details, see the description of group bA parameters.</p>	0-4	0

Parameter No.	Parameter Name	Description	Value Range	Default																												
A0.08	Crane mechanism selection	This parameter is used to select the crane mechanism driven by the AC drive. 0: Hoisting mechanism 1: Travel mechanism 2: Rotation mechanism	0-2	0																												
		<table border="1"> <thead> <tr> <th>Mechanism Type</th> <th>Parameter</th> <th>Description</th> </tr> </thead> <tbody> <tr> <td rowspan="5">Hoisting mechanism</td> <td>b1.00 = 0</td> <td>Changes the control mode to open-loop vector control.</td> </tr> <tr> <td>b6.03 = 30.0%</td> <td>Changes the brake release current to 30.0%.</td> </tr> <tr> <td>bC.02 = 0.50s</td> <td>Enables error 37#.</td> </tr> <tr> <td>bC.04 = 0.50s</td> <td>Enables error 38#.</td> </tr> <tr> <td>F1.00 = 60</td> <td>Changes speed loop gain 1 to 60.</td> </tr> <tr> <td rowspan="5">Travel mechanism</td> <td>b1.00 = 2</td> <td>Changes the control mode to V/F control.</td> </tr> <tr> <td>b6.03 = 0.0%</td> <td>Changes the brake release current to 0.0%.</td> </tr> <tr> <td>bC.02 = 0.0s</td> <td>Disables error 37#.</td> </tr> <tr> <td>bC.04 = 0.0s</td> <td>Disables error 38#.</td> </tr> <tr> <td>F1.00 = 30</td> <td>Changes speed loop gain 1 to 30.</td> </tr> <tr> <td>Rotation mechanism</td> <td>Same as the travel mechanism</td> <td></td> </tr> </tbody> </table>			Mechanism Type	Parameter	Description	Hoisting mechanism	b1.00 = 0	Changes the control mode to open-loop vector control.	b6.03 = 30.0%	Changes the brake release current to 30.0%.	bC.02 = 0.50s	Enables error 37#.	bC.04 = 0.50s	Enables error 38#.	F1.00 = 60	Changes speed loop gain 1 to 60.	Travel mechanism	b1.00 = 2	Changes the control mode to V/F control.	b6.03 = 0.0%	Changes the brake release current to 0.0%.	bC.02 = 0.0s	Disables error 37#.	bC.04 = 0.0s	Disables error 38#.	F1.00 = 30	Changes speed loop gain 1 to 30.	Rotation mechanism	Same as the travel mechanism	
		Mechanism Type			Parameter	Description																										
		Hoisting mechanism			b1.00 = 0	Changes the control mode to open-loop vector control.																										
					b6.03 = 30.0%	Changes the brake release current to 30.0%.																										
					bC.02 = 0.50s	Enables error 37#.																										
					bC.04 = 0.50s	Enables error 38#.																										
					F1.00 = 60	Changes speed loop gain 1 to 60.																										
		Travel mechanism			b1.00 = 2	Changes the control mode to V/F control.																										
					b6.03 = 0.0%	Changes the brake release current to 0.0%.																										
					bC.02 = 0.0s	Disables error 37#.																										
					bC.04 = 0.0s	Disables error 38#.																										
					F1.00 = 30	Changes speed loop gain 1 to 30.																										
		Rotation mechanism			Same as the travel mechanism																											
		Note:																														
When the value of A0.08 is changed, the values of parameters listed in the preceding table are also changed.																																

6 Parameter Table

Parameter No.	Parameter Name	Description	Value Range	Default
Group AF: level-1 menu auxiliary parameters				
AF.00	User password	This parameter is used to set the password for displaying and modifying all function parameters. If this parameter is set to a non-zero value, you must enter the password before entering any menu. If you enter wrong passwords consecutively three times, all menus are locked. In this case, you must power off and restart the AC drive. After this parameter is set to 0, the password is canceled.	0-65535	0
AF.01	Restore factory settings in the level-1 menu	0: No operation 1: Restore factory settings in the level-1 menu A0.00 to A0.05, A0.08 to A0.09, and AF.00 in the level-1 menu cannot be restored to factory settings.	0-1	0
AF.02	Display user-defined parameter settings in the level-1 menu	0: Display all level-1 menu parameters normally 1: Display only level-1 menu parameters with non-default values 2: Display all level-1 menu	0-2	0

6.2 Level-2 Menu (Group b, Group E*, Group U) Parameter Table

The level-2 menu contains basic function parameters, monitoring parameters, and fault record parameters of the AC drive. You can implement all functions of the AC drive by setting parameters in the level-2 menu. To improve the output performance of the AC drive, you need to set parameters in the level-3 menu.

You can enter the level-2 menu only after entering the correct password set by bF.00.

Parameter No.	Parameter Name	Description	Value Range	Default
Group b0: Basic motor parameters				
b0.00	Protection frequency of self ventilated motor running at a low speed	The two parameters are used for error 43# and provide protection for a self ventilated motor. The AC drive reports error 43# if the frequency of the AC drive stays below the value of b0.00 for a period longer than the value of b0.01.	0.01–20.00 Hz	5.00 Hz
b0.01	Low-speed running time of self ventilated motor	This function does not take effect if b0.01 is set to 0.	0s to 1000s	0s
b0.04	Auto-tuning option	0: No operation 1: Static auto-tuning for an asynchronous motor (some motor parameters obtained) 2: Dynamic auto-tuning for an asynchronous motor (all motor parameters obtained) 3: Static auto-tuning for an asynchronous motor (all motor parameters obtained)	0–3	0
b0.05	Power-on auto-tuning option	The CS710 series AC drive supports auto-tuning of stator resistance after power-on. If this function is enabled, the AC drive takes 2 to 3 seconds in static auto-tuning to achieve the optimal control effect every time it is powered on. 0: Function disabled 1: Function enabled	0–1	0
Group b1: Motor control parameters				
b1.00	Control mode	0: SVC (open-loop vector control) 1: FVC (closed-loop vector control) 2: V/F	0–2	0
b1.01	Slip compensation	This parameter is used to adjust the speed stability accuracy of the motor in SVC control mode. When the motor has a heavy load and runs at a too low speed, increase the value of this parameter. When the motor runs at a too high speed, decrease the value of this parameter. In the FVC control mode, this parameter can be used to change the output current of the AC drive under the same load.	50.0% to 200.0%	100.0%
b1.02	Maximum frequency	This parameter is used as the base value for calculating the target frequency when the frequency source is set to AI or serial communication. It indicates the maximum value of the AC drive's output frequency at any time.	50.00–150.00 Hz	50.00 Hz
b1.03	Minimum frequency	This parameter sets the minimum frequency of the AC drive's output frequency at any time.	0.00–15.00 Hz	0.00 Hz

6 Parameter Table

Parameter No.	Parameter Name	Description	Value Range	Default
b1.04	Forward torque upper limit	These two parameters are used to set the output torque upper limits when DI function 1 (Forward RUN) and DI function 2 (Reverse RUN) are enabled.	0.0% to 500.0%	180.0%
b1.05	Reverse torque upper limit	The values are percentages of the rated motor torque. In SVC (open-loop) control mode, the AC drive uses the value of 50.0% if the parameter values are smaller than 50.0%.		
b1.06	Forward torque upper limit during brake release	These two parameters take effect only when b6.00 is set to 2 (guide brake control). The torque upper limits set by the two parameters are used within the brake release time (b6.04) after the AC drive starts. After the brake is released completely, the torque upper limits change to the values set by b1.04 and b1.05.		150.0%
b1.07	Reverse torque upper limit during brake release			130.0%
Group b2: Encoder parameters				
b2.00	Encoder pulses per revolution (PPR)	This parameter is used to set the PPR of an ABZ or UVW incremental encoder. In the FVC mode, the PPR must be set properly to ensure normal running of the motor.	0–8192	1024
b2.01	Encoder type	<p>0: ABZ incremental encoder or differential encoder Use a PG card of the MD38PGMD model for this type of encoder.</p> <p>1: UVW incremental encoder Use a PG card of the MD38PG3 model for this type of encoder.</p> <p>2: Resolver Use a PG card of the MD38PG4 model for this type of encoder.</p> <p>3: Reserved</p> <p>4: Reserved</p> <p>The CS710 series AC drive supports multiple types of encoders, which are used with different PG cards. Choose an appropriate PG card for the encoder used. After installing the PG card, set this parameter properly to ensure normal running of the AC drive.</p>	0–4	0
b2.02	A/B phase sequence of ABZ incremental encoder	This parameter is valid only for an ABZ incremental encoder (b2.01 = 0). It is used to set the A/B phase sequence of the ABZ incremental encoder. During auto-tuning for an asynchronous motor, the AC drive automatically identifies the A/B phase sequence.	0–1	0
b2.03	Encoder disconnection detection option	This parameter is used to enable or disable detection of error 20# (encoder disconnection). When it is set to 1, detection of error 120# is enabled. When it is set to 0, error 120# is shielded.	0–1	1

Parameter No.	Parameter Name	Description	Value Range	Default
b2.07	Encoder disconnection detection time	This parameter is used to set the encoder hardware disconnection detection time and is valid only for a PG card of the MD38PGMD model. When it is set to 0, encoder disconnection detection is disabled. When signals of the encoder are abnormal, the AC drive reports error 120#.	0.000s to 1.000s	0.000s
Group b3: Input/Output parameters				
b3.00	Frequency source option B	0-4: Same as A0.07 5: Serial communication The CS710 series AC drive supports setting of the frequency source in the following four communication modes: Modbus, CANopen, PROFIBUS-DP, and PROFINET. Different communication modes are applicable to different communication extension cards and require different bd.07 settings. For details, see " 10.2 Communication Extension Cards " and description of bd.07. For the frequency data format in each communication mode, see the description of the specific communication mode.	0-6	0

6 Parameter Table

Parameter No.	Parameter Name	Description	Value Range	Default
b3.01	DI1 function option	1: Forward RUN 2: Reverse RUN The running direction of the AC drive is controlled by the input terminals programmed to these functions.	0-133 (Functions 1-33 are NO inputs. Functions 101-133 are NC inputs. 0 and 100 are invalid.)	1
b3.02	DI2 function option	3: Reset upon fault An input terminal programmed with this function can be used to reset the AC drive when a fault occurs. This terminal has the same function as the RESET key on the operating panel. This function can remotely Reset the AC drive.		2
b3.03	DI3 function option	4: Quick stop The AC drive provides output brake frequency (b6.05) immediately and executes the brake apply sequence normally. 5: Coast to stop		8
b3.04	DI4 function option	When the input terminal programmed to this function becomes active, the AC drive blocks output and does not control the deceleration process of the motor. This stop mode is the same as coast to stop described in b4.03. 6: Decelerate to stop		9
b3.05	DI5 function option	When the input terminal programmed to this function becomes active, the AC drive decelerates normally and stops the motor after the brake time sequence is complete. The effect of this stop mode is the same as that of cancellation of the RUN command.		3
b3.06	DI6 function option	7: External fault input When this signal is sent to the AC drive, the AC drive reports error 50#(external input fault). 8: Multi-frequency option 1 9: Multi-frequency option 2 10: Multi-frequency option 3 These functions are valid when the frequency source is set to multi-frequency. For details, see the description of b5 group parameters. 11: Brake release feedback 12: Brake applying feedback They are feedback input signals of errors 41# and 42#. For details, see the description of the two errors. 13: Second acceleration ramp switching 14: Second deceleration ramp switching 15: Third acceleration ramp switching 16: Third deceleration ramp switching They are the DI switching point input functions for the acceleration and deceleration time when running in a special curve. For details, see the description of group b8 special curve parameters.		5

Parameter No.	Parameter Name	Description	Value Range	Default														
b3.07	DI7 function option	<p>19: Acceleration 20: Deceleration</p> <p>They are used as the frequency increment and decrement commands when the frequency is determined by external terminals. The functions are valid when the frequency source is set to acceleration and deceleration.</p> <p>21: Torque/Speed control switchover</p>	0-133 (Functions 1-33 are NO inputs. Functions 101-133 are NC inputs. 0 and 100 are invalid.)	0														
b3.08	DI8 function option	<p>If the digital input programmed to this function becomes active, the AC drive changes to the torque control mode. If the input is not active, the AC drive changes to the speed control mode. For details, see the description of group bb torque control parameters.</p> <p>22: Forward stop switch 23: Reverse stop switch 24: Forward deceleration switch 25: Reverse deceleration switch</p>		0														
b3.09	DI9 function option	<p>After a stop switch takes effect, the AC drive performs the quick stop action (same as input function 4). After a deceleration switch takes effect, the maximum output frequency of the AC drive is limited below the value set by bF.16 (deceleration frequency limit).</p> <p>26: Positioning point shielding</p>		0														
b3.10	DI10 function option	<p>If input configured with this function is active, the stop and deceleration switch inputs are both invalid.</p> <p>27: Motor switchover switch 1 28: Motor switchover switch 2</p> <p>A CS710 AC drive has three sets of function parameters for switchover between three motors. The motor switchover function takes effect only after the AC drive stops output. If you select these two input functions for one motor, they are also forcibly selected for the same DIs of the other two motors. The 3 motors are selected from the binary combinations of the inputs, as described in the following table.</p> <table border="1" data-bbox="409 1166 740 1318"> <thead> <tr> <th>Input Function 28</th> <th>Input Function 27</th> <th>Motor SN</th> </tr> </thead> <tbody> <tr> <td>Off</td> <td>Off</td> <td>1#</td> </tr> <tr> <td>Off</td> <td>On</td> <td>2#</td> </tr> <tr> <td>On</td> <td>Off</td> <td>3#</td> </tr> <tr> <td>On</td> <td>On</td> <td>3#</td> </tr> </tbody> </table> <p>31: Position check</p>		Input Function 28	Input Function 27	Motor SN	Off	Off	1#	Off	On	2#	On	Off	3#	On	On	3#
Input Function 28	Input Function 27	Motor SN																
Off	Off	1#																
Off	On	2#																
On	Off	3#																
On	On	3#																
		<p>If the input programmed to this function becomes active,, the accumulative number of pulses in the AC drive is reset to b7.10 x b7.11, and the position value is reset to b7.11. For details, see the description of b7.10 and b7.11.</p>																

6 Parameter Table

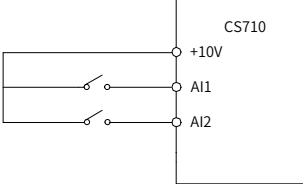
Parameter No.	Parameter Name	Description	Value Range	Default
b3.11	AI1 function option	When this parameter is set to 0, the corresponding AI input is used as the target frequency input or is not used. When it is set to a non-zero value, the input function is the same as b3.01 to b3.10. The input is active when the input voltage is greater than 7.00 V and is not active when the input voltage is lower than 3.00 V.	0-133 (Functions 1-33 are NO inputs. Functions 101-133 are NC inputs. 0 and 100 are invalid.)	0
b3.12	AI2 function option	The wiring shown in the following figure is recommended for digital input. 		

Parameter No.	Parameter Name	Description	Value Range	Default
b3.14	Relay 1 function option (T/A-T/B-T/C)	<p>1: Brake control This output is active when the brake release condition is met in the brake time sequence. For details, see the description of group b6 parameters.</p> <p>2: Stop upon fault This output becomes active after a level-1 fault occurs on the AC drive.</p> <p>3: Alarm upon fault</p>	0-118 (Functions 1 to 18 are NO outputs. Functions 101 to 118 are NC outputs. 0 and 100 are invalid.)	1
b3.15	Reserved	<p>This output becomes active after a level-2 or level-3 fault occurs on the AC drive.</p> <p>4: Fault message This output becomes active after a level-4 fault occurs on the AC drive.</p> <p>5: Motor 1 connected indication</p> <p>6: Motor 2 connected indication</p> <p>7: Motor 3 connected indication</p>		-
b3.16	DO1 function option	<p>If you select output functions 5 to 7 for one motor, they are also forcibly selected for the same outputs of the other two motors.</p> <p>8: AC drive overload pre-warning This output function provides a valid signal 10s before the AC drive triggers overload protection.</p> <p>9: Motor overload pre-warning Before triggering motor overload protection, the AC drive determines whether load of motor exceeds the overload pre-warning threshold. If the pre-warning threshold is exceeded, the output becomes active. For details on how to set motor overload parameters, see the description of bE.00 to bE.02.</p>		0
b3.17	DO2/Relay Y2 function option	<p>11: Overload protection start This output function takes effect after the AC drive changes to the overload protection state. For details, see the description of bE.13.</p> <p>12: Over-torque output This output function becomes active when the output torque of the AC drive exceeds the threshold set by bF.17 and is inactive when the output torque is smaller than 90% of the threshold. For details, see the description of bF.17.</p> <p>13: Motor fan control This output function takes effect after the AC drive starts to run and becomes invalid when the delay time set by bF.21 expires after the AC drive stops running.</p> <p>14: Frequency reached For details, see the description of bF.07 and bF.08.</p> <p>15: AC drive running This output function is valid when the AC drive is running and becomes invalid after the AC drive stops running.</p> <p>16: Automatic start The output is valid when the automatic start function of the AC drive is enabled. For details, see the description of bC.00.</p> <p>17: Reserved</p> <p>18: Communication control The output functions are controlled through serial communication.</p>		4

6 Parameter Table

Parameter No.	Parameter Name	Description	Value Range	Default
b3.18	FM function option	When the thousands position is set to 1, the FM output terminal is used for digital output. In this case, it provides the same output function as parameters b3.12 to b3.17. When the thousands position is set to 0, the FM output terminal is used for high-speed pulse output. In this case, it provides the same output function as parameters b3.19 to b3.20.	0–118 (Functions 1–18 are NO outputs. Functions 101–118 are NC outputs. 0 and 100 are invalid.)	0
b3.19	AO1 function option	When the thousands positions of the two parameters are set to 1, the AO terminals are used as digital output. In this case, they provide the same output functions as parameters b3.14 to b3.17, with 10.00 V output as active output and 0.00 V output as inactive output. When the thousands position is set to 0, the AO terminals are used as analog output, with the output range of 0.0% to 100% corresponding to the following items: 0: Output frequency... 0 to the maximum frequency 1: Output current... 0 to 2 times the rated current of the motor 2: Output torque... 0 to 2 times the rated torque of the motor 3: Output power... 0 to 2 times the rated power of the motor 4: Output voltage... 0 to 1.2 times the rated voltage of the motor 5: Target frequency... 0 to the maximum frequency 6: Communication control The output is controlled through serial communication. For details, see the description of U0.15 and U0.16.		0
	AO2 function option			0
b3.20	Relay Y1 function option			
	P/A-P/C function selection (MD38IO3, CS700IO1)			
b3.21	DI filter time	This parameter is used to set the software filter time of DI terminal status. If DI terminals are liable to receive disturbances, which may cause malfunction, increase the value of this parameter to enhance the anti-interference capability. However, increasing the DI filter time will slow the response of DI terminals.	0.000s to 1.000s	0.010s

Parameter No.	Parameter Name	Description	Value Range	Default
b3.22	AI1 minimum input	Parameters b3.22 to b3.26 are used to define the relationship between analog input voltages and configured values. When the analog input voltage exceeds the maximum value, the maximum value is used. When the analog input voltage is less than the minimum value, the value set for the condition of "AI lower than minimum input" or 0.0% is used. When the analog input is current input, 1 mA current corresponds to 0.5 V voltage. b3.26 (AI1 filter time) is used to set the software filter time of AI. If the analog input is liable to receive disturbances, increase the value of this parameter to stabilize the detected analog input. However, increasing the AI filter time will slow the response of analog detection. Set this parameter properly based on actual conditions. In different applications, 100% of analog input corresponds to different nominal values. For details, see the description of different applications.	0.00 V to b3.24	0.00 V
b3.23	Setting corresponding to AI1 minimum input		0.0 to 100.0%	0.0%
b3.24	AI1 maximum input		b3.22 to 10.00 V	10.00 V
b3.25	Setting corresponding to AI1 maximum input		0.0 to 100%	100.0%
b3.26	AI1 filter time		0.00s to 10.00s	0.10s
b3.27	AI2 minimum input		For the specific function and usage, see the description of b3.22 to b3.26.	0.00 V to b3.29
b3.28	Setting corresponding to AI2 minimum input	0.0 to 100.0%		0.0%
b3.29	AI2 maximum input	b3.27 to 10.00 V		10.00 V
b3.30	Setting corresponding to AI2 maximum input	0.0 to 100%		100.0%
b3.31	AI2 filter time	0.00s to 10.00s		0.10s

6 Parameter Table

Parameter No.	Parameter Name	Description	Value Range	Default
b3.43	AO1 zero offset coefficient	These parameters are used to correct the offset of the analog output zero drift and the output amplitude. They can also be used to define the required AO curve. If b represents zero offset, k represents gain, Y represents actual output, and X represents standard output, the actual output is $Y = kX + b$. Zero offset coefficient 100% of AO1 and AO2 corresponds to 10 V or 20 mA. A standard output is the value corresponding to 0 to 10 V or 0 to 20 mA without offset or gain. For example, the analog output is frequency. If you want the AC drive to provide 8 V output when the frequency is 0 and provide 3 V output when the frequency reaches the maximum value, set the gain to -0.50 and the zero offset to 80%.	-100.0% to +100.0%	0.0%
b3.44	AO1 gain		-10.00 to +10.00	1.00
b3.45	AO2 zero offset coefficient		-100.0% to +100.0%	0.0%
b3.46	AO2 gain		-10.00 to +10.00	1.00
Group b4: Ramp parameters				
b4.00	Acceleration time	Acceleration time (t1 in the following figure) is the time required for the AC drive to accelerate from 0 to the rated frequency (A0.04). Deceleration time (t2 in the following figure) is the time required for the AC drive to decelerate from the rated frequency (A0.04) to 0.	0.0s to 600.0s	3.0s
b4.01	Deceleration time			
b4.02	Running curve model option	0: Linear acceleration/deceleration The output frequency increases or decreases linearly. 1: S-curve acceleration/deceleration The output frequency increases or decreases with an S curve. This type is applicable to the scenarios that require soft start or stop.	0-1	0
b4.03	Stop mode option	0: Decelerate to stop After the stop command takes effect, the AC drive decelerates with the ramp based on the deceleration time set by b4.01. 1: Coast to stop After the stop command takes effect, the AC drive stops output immediately. Then the motor coasts to stop due to mechanical inertia.	0-1	0

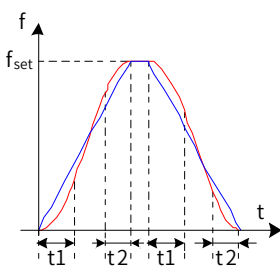
Parameter No.	Parameter Name	Description	Value Range	Default																																				
b4.04	Time proportion of S-curve initial segment	<p>The two parameters respectively define the time proportions of the initial and final segments for S-curve acceleration and deceleration. In the following figure, t1 is defined by b4.04, within which the change rate of the output frequency increases gradually. t2 is defined by b4.05, within which the change rate of the output frequency gradually decreases to 0. In the remaining between t1 and t2, the change rate of output frequency remains unchanged. That is, the output frequency increases or decreases linearly.</p> 	0.0 to 40.0%	30.0%																																				
b4.05	Time proportion of S-curve final segment																																							
Group b5: Multi-frequency parameters																																								
b5.00	Frequency 1	<p>The multi-frequency fsetpoints are selected by input functions 8, 9, and 10. Digital combinations of the three input functions allow to select eight frequencies, as listed in the following table.</p> <table border="1" data-bbox="358 917 789 1173"> <thead> <tr> <th>Input Function 10</th> <th>Input Function 9</th> <th>Input Function 8</th> <th>Target Speed</th> </tr> </thead> <tbody> <tr> <td>Off</td> <td>Off</td> <td>Off</td> <td>b5.00</td> </tr> <tr> <td>Off</td> <td>Off</td> <td>On</td> <td>b5.01</td> </tr> <tr> <td>Off</td> <td>On</td> <td>Off</td> <td>b5.02</td> </tr> <tr> <td>Off</td> <td>On</td> <td>On</td> <td>b5.03</td> </tr> <tr> <td>On</td> <td>Off</td> <td>Off</td> <td>b5.04</td> </tr> <tr> <td>On</td> <td>Off</td> <td>On</td> <td>b5.05</td> </tr> <tr> <td>On</td> <td>On</td> <td>Off</td> <td>b5.06</td> </tr> <tr> <td>On</td> <td>On</td> <td>On</td> <td>b5.07</td> </tr> </tbody> </table>	Input Function 10	Input Function 9	Input Function 8	Target Speed	Off	Off	Off	b5.00	Off	Off	On	b5.01	Off	On	Off	b5.02	Off	On	On	b5.03	On	Off	Off	b5.04	On	Off	On	b5.05	On	On	Off	b5.06	On	On	On	b5.07	Minimum frequency (b1.03) to maximum frequency (b1.02)	5.00 Hz
Input Function 10	Input Function 9		Input Function 8	Target Speed																																				
Off	Off		Off	b5.00																																				
Off	Off		On	b5.01																																				
Off	On		Off	b5.02																																				
Off	On		On	b5.03																																				
On	Off		Off	b5.04																																				
On	Off		On	b5.05																																				
On	On	Off	b5.06																																					
On	On	On	b5.07																																					
b5.01	Frequency 2	20.00 Hz																																						
b5.02	Frequency 3	35.00 Hz																																						
b5.03	Frequency 4	50.00 Hz																																						
b5.04	Frequency 5	0.00 Hz																																						
b5.05	Frequency 6																																							
b5.06	Frequency 7																																							
b5.07	Frequency 8																																							

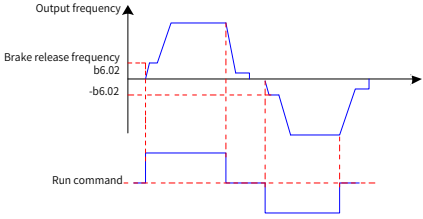
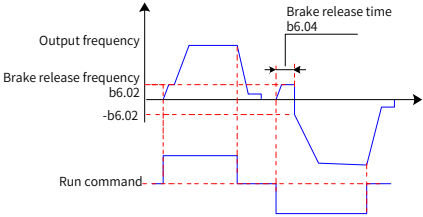
Parameter No.	Parameter Name	Description	Value Range	Default
Group b6: Braking logic control parameters				
b6.00	Braking curve type	<p>0: No brake control The AC drive does not define the brake release frequency, brake release time, or brake applying time. Output function 1 is equivalent to the output function of "AC drive running".</p> <p>1: Automatic brake control The AC drive automatically retains current (with torque upper limits set by b1.04 and b1.05) within the brake release time. When the output current reaches the product of b6.03 multiplied by the motor's rated current, the AC drive activates the signal to release the brake.</p> <p>2: Guide brake control The AC drive uses values set by b1.06 and b1.07 as torque upper limits. When the output current reaches the product of b6.03 multiplied by the motor's rated current, the AC drive turns ON the output signal to release the brake. For details, see the description of b1.06 and b1.07.</p>	0-3	1
b6.01	Startup direction	<p>This parameter is used to set the output torque direction of the AC drive within the brake release time.</p> <p>0: Brake release torque the same as running direction</p>  <p>1: Brake release torque always forward rotation direction</p> 	0-1	0
b6.02	Brake release frequency	This parameter is used to set the output frequency of the AC drive before the brake releases completely, namely, the minimum frequency at which the motor can have full torque.	Minimum frequency (b1.03) to 15.00 Hz	2.00 Hz

Parameter No.	Parameter Name	Description	Value Range	Default
b6.03	Brake release current	This parameter is used to set the percentage of the AC drive's output current to the motor's rated current (A0.03). When the output current of the AC drive reaches this value, the AC drive turns ON the output signal to release the brake immediately (output function 1 enabled).	0.0 to 150.0%	30.0%
b6.04	Brake release time	This parameter is used to set the time from start and complete of mechanical brake release. The AC drive keeps the output at the brake release frequency within this period of time.	0.00 to 5.00s	0.50s
b6.05	Brake applying frequency	When the output frequency of the AC drive falls below this value during deceleration after the RUN command is canceled, the AC drive turns OFF the output signal to apply the brake (output function 1 inactive).	Minimum frequency (b1.03) to 20.00 Hz	2.00 Hz
b6.06	Brake applying time	This parameter is used to set the time from start and complete of the mechanical brake applying process. The AC drive keeps the output at the brake applying frequency within this period of time.	0.00 to 5.00s	0.50s
b6.07	Brake applying delay	This parameter is used to set the delay time before the AC drive turns OFF the output signal to apply the brake when the brake apply condition is met. This function is invalid when quick stop or coast to stop is selected and the crane mechanism type (A0.08) is set to 0, 3, or 4 respectively.	0.0 to 30.0s	0.0s

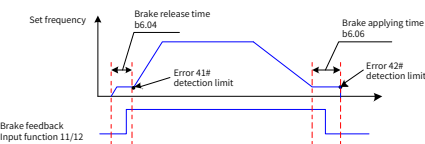
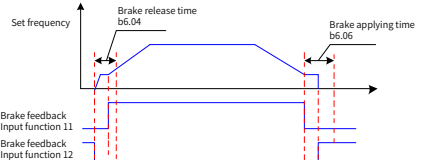
Parameter No.	Parameter Name	Description	Value Range	Default
b6.08	Brake feedback purpose	<p>This parameter relates to detection of errors 41# and 42#. For details, see the description of the two errors.</p> <p>0: Brake feedback not used The brake feedback signals are not connected to the AC drive or do not need the brake feedback function.</p> <p>1: Used for detection at brake action The AC drive detects brake feedback signals only during brake applying and release processes. This application requires only one brake feedback contact input. The following figure shows the application logic.</p>  <p>2: Used for whole process monitoring The brake release time and brake applying time settings are determined by the brake feedback contact signal. The AC drive starts to check brake feedback signals immediately after being powered on. In this application, both the brake release contact and brake applying contact must be connected to the AC drive. The following figure shows the application logic.</p> 	0-2	0

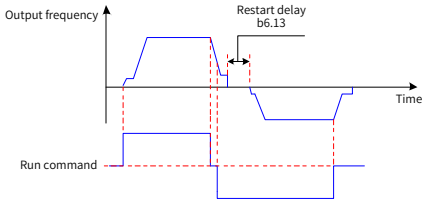
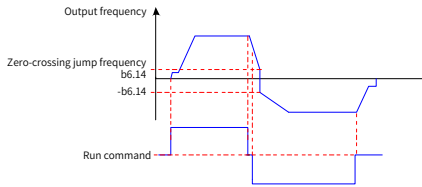
Parameter No.	Parameter Name	Description	Value Range	Default
b6.09	Command reverse control	<p>0: Direct reverse not allowed during running When the running AC drive receives the reverse RUN command, it decelerates following the normal stop process, and then starts reverse running.</p>  <p>1: Direct reverse allowed during running When the running AC drive receives the reverse RUN command, it decelerates to the zero-crossing jump frequency (b6.14), and then directly starts reverse running from the reversed zero-crossing jump frequency. Brake applying and release control are not performed in this process.</p>  <p>When the crane mechanism type is set to hoisting mechanism (A0.08 = 0), this function is valid only in closed-loop control mode. When other mechanism types are selected, this function is valid in all control modes.</p>	0-1	0

6 Parameter Table

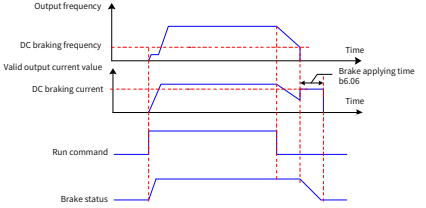
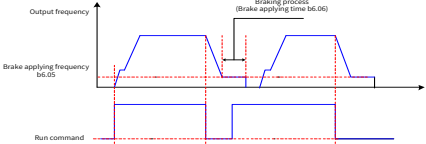
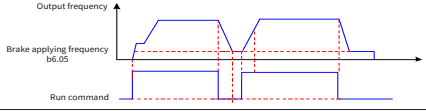
Parameter No.	Parameter Name	Description	Value Range	Default
b6.10	DC braking current	<p>Parameter b6.10 is used to set the percentage of the AC drive's output current in DC braking mode to the rated current of the motor. A larger value of this parameter results in a better DC braking performance, but causes more heats on the motor and the AC drive.</p> <p>During the process of decelerating to stop, the AC drive starts DC braking when the running frequency falls below the value of parameter b6.11. After entering the DC braking state, the AC drive sends a brake applying command.</p>	0% to 120%	50%
b6.11	DC braking frequency		Minimum frequency (b1.03) to rated frequency (A0.04)	0.00 Hz
b6.12	Restart during braking	<p>0: Restart not allowed during braking The AC drive does not accept the RUN command if the brake has started to apply in the stop process. The AC drive can restart only after the brake is applied completely and the AC drive stops output.</p>  <p>1: Restart allowed during braking The AC drive accepts a new RUN command during the stop process even if the brake has started to apply.</p> 	0-1	0
b6.13	Restart delay time	This parameter is used to set the delay time the AC drive must wait before a restart every time it stops. For details, see the description of b6.09.	0.0 to 15.0s	0.3s

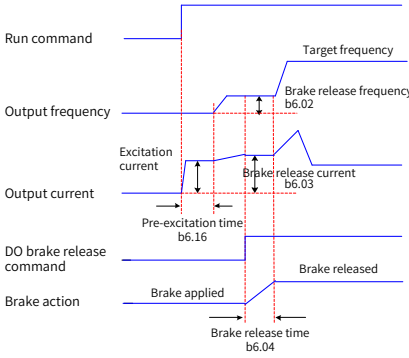
Parameter No.	Parameter Name	Description	Value Range	Default
b6.14	Zero-crossing jump frequency	If the AC drive allows command reverse control (b6.09 = 1) and the output frequency falls below the value of b6.14 during deceleration, the output frequency will jump from b6.14 to -b6.14. The actual value of this parameter must be larger than the brake release frequency b6.02 and brake apply frequency b6.05. For details, see the description of b6.09.	0.00 to 20.00 Hz	2.00 Hz
b6.16	Pre-excitation time	 <p>This parameter is used to set how long the pre-excitation stage lasts during AC drive startup. This function takes effect only in the closed-loop vector control mode. When it is set to 0, the pre-excitation function is invalid.</p>	0.00 to 5.00s	0.30s
b6.17	Excitation holding time after stop	This parameter is used to set the holding time of the excitation state after the AC drive stops. In the excitation holding time, the AC drive provides zero speed output and retains excitation current. If the AC drive receives the RUN command during this period, it can skip the pre-excitation stage and release the brake quickly.	0 to 65535s	30s
b6.18	Droop adjustment speed	This parameter is read-only. It shows the difference value between the set frequency and actual frequency after droop calculation. See the description of b6.19 for more details.	-	-

6 Parameter Table

Parameter No.	Parameter Name	Description	Value Range	Default
b6.19	Droop rate	<p>This parameter is used to set the droop rate for droop control. When it is set to 0, the droop control function is disabled.</p> <p>Droop control is applicable to scenarios where two AC drives work together to drive two motors in rigid connection. To prevent running conflict between the two motors, droop control allows minor speed deviation between the two motors.</p> <p>The droop rate is calculated using the following formula: Droop adjustment speed (b6.18) = Synchronous frequency x Output torque x Droop rate (b6.19)/10</p> <p>Example: If b6.19 = 1.00, the synchronous frequency is 50.00 Hz, and the output torque is 50.0%, then: Droop adjustment speed = 50.00 Hz x 50.0% x 1.00/10 = 2.50 Hz</p> <p>Actual frequency of the AC drive = 50.00 Hz - 2.50 Hz = 47.50 Hz</p>	0.00 to 20.00	0.00

Parameter No.	Parameter Name	Description	Value Range	Default
Group b7: Light-load and positioning control parameters				
b7.00	Flux weakening multiplier	The light-load high-speed function enables the AC drive to automatically calculate the maximum output frequency when the target frequency is greater than the rated frequency, thereby preventing faults caused by a heavy load, such as overload and overcurrent. Parameters b7.00 to b7.07 are used to set the light-load high-speed function. When the output frequency of the AC drive reaches the value of b7.07, the AC drive retains the output frequency for the time set by b7.06. When the time expires, the AC drive measures the output torque T and uses it to calculate the maximum frequency F for running according to the curve shown in the following figure. If the target frequency is greater than the rated frequency and the value of b7.00 exceeds 100.0%, the light-load high-speed function is enabled. When $T \leq$ losing rope torque or $T \geq$ allowed load, the maximum value of F is the rated frequency. When losing rope torque $< T \leq$ light-load coefficient, the maximum value of F is $b7.00 \times$ rated frequency. When light-load coefficient $< T <$ allowed load, F is automatically adjusted according to the following curve.	100.0% to 300.0%	100.0%
b7.01	Loosing rope torque		0.0% to light-load coefficient (b7.02)	5.0%
b7.02	Light-load coefficient		Loosing rope torque (b7.01) to allowed load (b7.03)	35.0%
b7.03	Allowed load		Light-load coefficient (b7.02) to 100.0%	80.0%
b7.06	Detection time		0.0 to 5.0s	0.5s
b7.07	Detection frequency	Brake release frequency (b6.02) to rated frequency (A0.04)	40.00 Hz	
b7.08	Forward correction	<p>Flux weakening multiplier $b7.00 \times$ Rated frequency A0.04</p> <p>Running frequency</p> <p>Rated frequency A0.04</p> <p>Loosing rope torque b7.01 Light-load coefficient b7.02 Detection torque Allowed load b7.03 Torque</p>	0–100%	100%
b7.09	Reverse correction		b7.08 and b7.09 determine whether the target frequency of the AC drive is $F \times b7.08$ (running in forward direction) or $F \times b7.09$ (running in reverse direction) when light-load coefficient $\leq T \leq$ allowed load. The actual running frequency is also limited by the maximum torque of the AC drive or motor.	0–100%
b7.10	Position display proportion	You need to set this parameter based on the position display accuracy. It is used to convert the number of pulses into position data. Position data displayed in U0.08 and U0.09 is the current number of pulses divided by b7.10. Note: The pulses provided to CS710 AC drive are quadruplicated.	1–65535	1

6 Parameter Table

Parameter No.	Parameter Name	Description	Value Range	Default
b7.11	Position check value	When input function 31 (position check) is valid, the accumulative number of pulses in the AC drive is reset to b7.10 x b7.11, and the position data is reset to the value of this parameter.	0-65535	0
Group b8: Special curve parameters				
b8.00	Special acceleration	<p>0: Disabled Special acceleration is not used.</p> <p>1: Two-segment (frequency switchover) Two-segment acceleration/deceleration is used. When the output frequency exceeds rated frequency x b8.04 during the acceleration process, the acceleration time changes to the value of b8.02. When the output frequency falls below rated frequency x b8.05 during the deceleration process, the deceleration time changes to the value of b8.03.</p> <p>2: Three-segment (frequency switchover) Three-segment acceleration/deceleration is used. On the basis of segment 2, when the output frequency exceeds rated frequency x b8.08 during the acceleration process, the acceleration time changes to the value of b8.06. When the output frequency falls below rated frequency x b8.09 during the deceleration process, the deceleration time changes to the value of b8.07.</p>	0-4	0
b8.01	Special deceleration	<p>3: Two-segment (DI switchover) Two-segment acceleration/deceleration is used. When input function 13 takes effect during the acceleration process, the acceleration time changes to the value of b8.02. When input function 14 takes effect during the deceleration process, the deceleration time changes to the value of b8.03.</p> <p>4: Three-segment (DI switchover) Three-segment acceleration/deceleration is used. On the basis of segment 2, when input function 15 takes effect during the acceleration process, the acceleration time changes to the value of b8.06. When input function 16 takes effect during the deceleration process, the deceleration time changes to the value of b8.07.</p>		

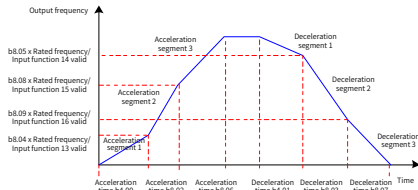

Parameter No.	Parameter Name	Description	Value Range	Default	
b8.02	Segment-2 acceleration time	For details, see the description of b8.00 and b8.01.	0.1s to 600.0s	3.0s	
b8.03	Segment-2 deceleration time		0.1s to 600.0s	3.0s	
b8.04	Segment-2 acceleration switchover frequency		0% to segment-3 acceleration switchover frequency (b8.08)	0%	
b8.05	Segment-2 deceleration switchover frequency		Segment-3 deceleration switchover frequency (b8.09) to 99%	99%	
b8.06	Segment-3 acceleration time		0.1s to 600.0s	3.0s	
b8.07	Segment-3 deceleration time		0.1s to 600.0s	3.0s	
b8.08	Segment-3 acceleration switchover frequency		Segment-2 acceleration switchover frequency (b8.04) to 99%	99%	
b8.09	Segment-3 deceleration switchover frequency		0% to segment-2 deceleration switchover frequency (b8.05)	0%	
Group bA: Acceleration/Deceleration parameters					
bA.00	Acceleration/Deceleration rate		This parameter is used to set the frequency change rate when the frequency source is set to acceleration/deceleration or input function 19 (acceleration) and input function 20 (deceleration) are active.	0.01–50.00 Hz/s	5.00 Hz/s

6 Parameter Table

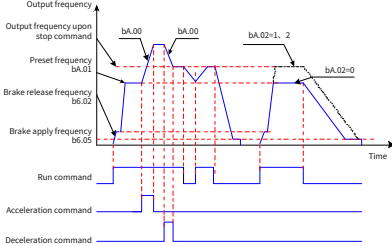
Parameter No.	Parameter Name	Description	Value Range	Default
bA.01	Preset frequency	This parameter is used to set the initial value of the target frequency when the frequency source is acceleration/deceleration.	Brake release frequency (b6.02) to maximum frequency (b1.02)	50.00 Hz
bA.02	Frequency retentive option	<p>0: Non-retentive The value of bA.01 is used as the initial target frequency every time.</p> <p>1: Retentive until power failure The value of bA.01 is used as the initial target frequency for the first run of the AC drive after power-on. If the power is not cut off, the initial target frequency is always the output frequency of the AC drive when it receives the STOP command last time.</p> <p>2: Retentive all along The initial target frequency is the frequency set when the AC drive starts to decelerate after receiving the STOP command last time. This frequency value is saved upon a power failure.</p> 	0-2	0
bA.03	Minimum frequency for acceleration/deceleration	This parameter is used to set the lower limit of the output frequency during deceleration when the deceleration switch is active.	0-15.00	0.00 Hz

Parameter No.	Parameter Name	Description	Value Range	Default
Group bb: Torque control parameters				
bb.00	Torque control function option	<p>0: No torque control The frequency control mode is used all the time.</p> <p>1: Torque control all along The torque control mode is used all the time.</p> <p>2: Torque control with frequency switchover The torque control mode is used when the output frequency of the AC drive is greater than the value of bb.01. Otherwise, the frequency control mode is used.</p> <p>3: Torque control with torque switchover The torque control mode is used when the output torque of the AC drive is greater than the value of bb.02. Otherwise, the frequency control mode is used.</p> <p>4: Torque control with frequency and torque switchover The torque control mode is used when the output frequency of the AC drive is greater than the value of bb.01 and the output torque is greater than the value of bb.02. Otherwise, the frequency control mode is used.</p> <p>5: Torque control with DI switchover The torque control mode is used when input function 21 is active, and the frequency control mode is used when this function is not active.</p> <p>6: Torque control with communication switchover</p>	0-6	0
bb.01	Frequency switchover threshold	For details, see the description of bb.00.	0.00 to maximum frequency (b1.02)	25.00 Hz
bb.02	Torque switchover threshold		0.0% to 150.0%	50.0%
bb.03	Torque source	<p>1: AI1 AI1 supports only 0 to 10 V voltage input.</p> <p>2: AI2 AI2 supports 0 to 10 V voltage input or 4 to 20 mA current input, determined by jumper J9 on the control board.</p> <p>When AI is used as the torque source, 100% of voltage/current input corresponds to 200% of output torque.</p> <p>4: Operating panel, with the value set by bb.08</p> <p>5: Serial communication, with torque setpoint written at address 0xbb08</p>	0-5	0

6 Parameter Table

Parameter No.	Parameter Name	Description	Value Range	Default
bb.04	Forward maximum frequency in torque control	<p>These two parameters set the maximum frequency in forward or reverse rotation when the torque control mode is used.</p> <p>In torque control mode, if the load torque is smaller than the output torque of the motor, the motor speed keeps increasing. Therefore, the motor speed must be controlled in a proper range to prevent accidents such as runaway.</p>	0.00 Hz to maximum frequency (b1.02)	50.00 Hz
bb.05	Reverse maximum frequency in torque control			
bb.06	Torque control acceleration time	<p>In torque control mode, the difference between the motor's output torque and the load torque determines the speed change rate of the motor and load. The motor speed may change quickly, resulting in loud noise or high mechanical stress. Setting proper acceleration and deceleration times in torque control can ensure smooth change of the motor speed. If the motor needs to respond to torque changes quickly, set this parameter to 0.0s.</p> <p>For example, two motors are rigidly connected to drive the same load. To ensure balanced load distribution, set one AC drive as the master in frequency control and the other as the slave in torque control.</p> <p>The slave receives the master's output torque as the torque command and must follow the master rapidly. In this case, the acceleration/deceleration time of the slave in torque control is set to 0.0s. The time base of the two parameters is 200.0% of the output torque.</p>	0.0s to 600.0s	0.0s
bb.07	Torque control deceleration time			
bb.08	Target torque	This parameter is used to set the torque setpoint used when bb.03 is set to 4 or 5.	-500.0% to +500.0%	180.0%
bb.09	Connection method	<p>The torque control mode is usually used for master-slave control among multiple AC drives. The master AC drive uses the frequency control mode, and the slave drives use the torque control mode. This parameter determines the type of connection used between master and slave drives.</p> <p>0: Rigid connection 1: Non rigid connection</p>	0-1	0

Parameter No.	Parameter Name	Description	Value Range	Default
Group bC: Overspeed protection parameters				
bC.00	Number of pulses for automatic start	This parameter is used to set the automatic start function of the AC drive. When the AC drive runs in closed-loop mode with the brake closed, the AC drive can automatically run with 0 Hz output if it detects that the encoder pulse change quantity reaches the value of this parameter. Meanwhile, the AC drive reports error E453#, and output function 16 takes effect. This function prevents sliding caused by loose brake and enables the AC drive to send loose brake pre-warning.	0–65535	0
bC.02	Abnormal frequency detection period	This parameter is used to set the error 37# detection time. When the motor feedback frequency keeps in an opposite direction to the given frequency in a period longer than the value set by bC.02, the AC drive reports error 37#. If this parameter is set to 0, error 37# is disabled.	0.00s to 1.00s	0.50s
bC.03	Frequency following error	This parameter is used to set the error 38# detection threshold. For details, see the description of bC.04 or error 38#.	0 to 30%	20%
bC.04	Frequency following detection period	This parameter is used to set the error 38# detection time. When the difference between the motor feedback frequency and frequency setpoint stays above bC.03 x rated frequency in a period longer than the value set by bC.04, the AC drive reports error 38#. If this parameter is set to 0, error 38# is disabled. Error 38# is invalid if both the frequency setpoint and actual output frequency are greater than the rated frequency.	0.00s to 1.00s	0.50s
Group bD: Communication parameters				
bd.00	Baud rate	This parameter is used to set the speed of data transmission between the host controller and the AC drive in Modbus communication mode. The baud rate of the host controller must be the same as that of the AC drive. Otherwise, the host controller and AC drive cannot communicate with each other. A higher baud rate results in a faster communication speed. 5: 9600 bps 6: 19200 bps 7: 38400 bps 8: 57600 bps 9: 115200 bps	5–9	5

6 Parameter Table

Parameter No.	Parameter Name	Description	Value Range	Default
bd.01	Data format	This parameter is used to set the data format used in Modbus communication mode. The data format on the host controller must be the same as that on the AC drive. Otherwise, the host controller and AC drive cannot communicate with each other. 0: No check , with data format of <8, N, 2> 1: Even parity check , with data format of <8, E, 1> 2: Odd parity check , with data format of <8, O, 1> 3: No check , with data format of <8, N, 1>	0-3	0
bd.02	Local address	When the local address is set to 0 (broadcast address), the AC drive communicates with the host controller in broadcast mode. The local address (except the broadcast address) is unique, which is the prerequisite for point-to-point communication between the host controller and AC drive.	0-247	1
bd.03	Extension card response delay	This parameter is used to set the time that the AC drive waits before sending data to the host controller after it finishes receiving data. If the response delay is shorter than the system processing time, the system processing time prevails. If the response delay is longer than the system processing time, the AC drive does not send data to the host controller after finishing data processing, until the response delay expires. This parameter is valid only for RS-485 communication.	0-20 ms	2 ms
bd.04	Extension card timeout interval	If the communication interval between the AC drive and communication extension card exceeds the timeout interval, the AC drive reports error 48#. This parameter is valid only for Modbus RTU, PROFIBUS-DP, CANopen, and PROFINET communication modes.	0.0 to 60.0s	0.0s
bd.07	Extension card option	0: Modbus RTU communication 1: PROFIBUS-DP communication 2: CANopen communication/PROFINET communication Different communication modes require different extension cards.	0-2	0
bd.08	Extension card software version	This parameter sets the software version of the optional extension card in use, such as a PROFIBUS-DP, CANopen, or PROFINET card.	0-65535	0

Parameter No.	Parameter Name	Description	Value Range	Default
bd.11 to bd.30	User-defined parameter 1 to user-defined parameter 20	<p>The 20 parameters are user-defined parameters. You can use these parameters to redefine parameter and address mapping in a CS710 AC drive. For example, if bd.11 is set to A0.01, you can obtain the value of A0.01 by reading the bd.11 address.</p> <p>These user-defined parameters enable data with discrete addresses to be read continuously. For example, if values of A0.01, b0.05, and F0.04 need to be read circularly in Modbus RTU communication, three data frames need to be sent. Using these user-defined parameters, you can set bd.11, bd.12, and bd.13 to A0.01, b0.05, and F0.04 respectively. Then only one data frame needs to be sent to read the three continuous data values starting with bd.11.</p> <p>In PROFIBUS-DP communication and CANopen communication, each user-defined parameter is mapped to a communication address (one-to-one mapping).</p> <p>PROFIBUS-DP communication: bd.11-bd.20 are mapped to master-to-slave PROFIBUS-DP communication registers PZD3-PZD12. bd.21-bd.30 are mapped to slave-to-master PROFIBUS-DP communication registers PZD3-PZD12.</p> <p>CANopen communication: bd.11-bd.18 are mapped to CANopen communication registers RPDO2-RPDO3. bd.21-bd.28 are mapped to CANopen communication registers TPDO2-TPDO3.</p>	A0-00 to A*-** b0-00 to b*-** U0-00 to U*-** F0-00 to F*-**	0
Group bE: Fault and protection parameters				

6 Parameter Table

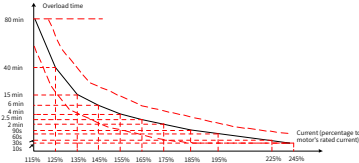
Parameter No.	Parameter Name	Description	Value Range	Default
bE.00	Motor overload protection	<p>To provide effective protection for motors with different loads, you need to set this parameter properly. The motor overload protection curve is an inverse time curve, as shown in the following figure.</p>  <p>When the running current of the motor reaches 175% of its rated current, the AC drive reports a motor overload error (11#) after the motor runs in this state for 2 minutes. When the running current of the motor reaches 115% of its rated current, the AC drive reports a motor overload error (11#) after the motor runs in this state for 80 minutes.</p> <p>Example: The rated current of the motor is 100 A.</p> <p>If bE.01 is set to 1.00 and the running current of the motor reaches 125 A (125% of 100 A), the AC drive reports a motor overload error after the motor runs in this state for 40 minutes.</p> <p>If bE.01 is set to 1.20 and the running current of the motor reaches 125 A (125% of 100 A), the AC drive reports a motor overload error after the motor runs in this state for 48 (40 x 1.2) minutes.</p> <p>The maximum time for reporting a motor overload error is 80 minutes, and the minimum time is 10 seconds.</p> <p>Example of setting motor overload protection: The AC drive needs to report a motor overload error after the motor runs for 2 minutes at 150% of rated current. Seen from the overload curve, 150% (I) of rated current is between 145% (I1) and 155% (I2) of rated current. The overload error reporting time for 145% of rated current is 6 minutes (T1), and that for 155% of rated current is 4 minutes (T2). Therefore, the overload error reporting time for 150% of rated current in default setting is calculated as follows: $T = T_1 + (T_2 - T_1) \times (I - I_1) / (I_2 - I_1) = 4 + (6 - 4) \times (150\% - 145\%) / (155\% - 145\%) = 5 \text{ (minutes)}$</p> <p>If you want the AC drive to report a motor overload error after the motor runs continuously for 2 minutes at 150% of rated current, the motor overload protection gain should be: $bE.01 = 2/5 = 0.4$</p> <p>Caution: Set bE.01 properly based on the actual overload capacity of the motor. If the value is too large, the AC drive may not report an alarm when the motor overheats and will be damaged.</p> <p>The motor overload pre-warning coefficient is the percentage to the time during which the motor runs at an overload current but a motor overload error is not reported. When the motor overload detection time reaches the value set by this parameter, output function 9 (motor overload pre-warning) takes effect.</p> <p>For example, if the motor overload protection gain is set to 1.00 and the overload pre-warning coefficient is set to 80%, output function 9 (motor overload pre-warning) takes effect after the motor runs consecutively for 4.8 minutes (80% x 6 minutes) at 145% of rated current.</p>	0: Motor overload protection disabled 1: Motor overload protection enabled	1
bE.01	Motor overload protection gain	<p>The AC drive needs to report a motor overload error after the motor runs for 2 minutes at 150% of rated current. Seen from the overload curve, 150% (I) of rated current is between 145% (I1) and 155% (I2) of rated current. The overload error reporting time for 145% of rated current is 6 minutes (T1), and that for 155% of rated current is 4 minutes (T2). Therefore, the overload error reporting time for 150% of rated current in default setting is calculated as follows: $T = T_1 + (T_2 - T_1) \times (I - I_1) / (I_2 - I_1) = 4 + (6 - 4) \times (150\% - 145\%) / (155\% - 145\%) = 5 \text{ (minutes)}$</p> <p>If you want the AC drive to report a motor overload error after the motor runs continuously for 2 minutes at 150% of rated current, the motor overload protection gain should be: $bE.01 = 2/5 = 0.4$</p> <p>Caution: Set bE.01 properly based on the actual overload capacity of the motor. If the value is too large, the AC drive may not report an alarm when the motor overheats and will be damaged.</p> <p>The motor overload pre-warning coefficient is the percentage to the time during which the motor runs at an overload current but a motor overload error is not reported. When the motor overload detection time reaches the value set by this parameter, output function 9 (motor overload pre-warning) takes effect.</p> <p>For example, if the motor overload protection gain is set to 1.00 and the overload pre-warning coefficient is set to 80%, output function 9 (motor overload pre-warning) takes effect after the motor runs consecutively for 4.8 minutes (80% x 6 minutes) at 145% of rated current.</p>	0.20-10.00	1.00

Parameter No.	Parameter Name	Description	Value Range	Default
bE.02	Motor overload pre-warning coefficient	<p>The AC drive can send a pre-warning signal to the control system through DO terminals before triggering motor overload protection. The pre-warning coefficient determines how early the AC drive sends the pre-warning signal before motor overload protection.</p> <p>The larger the value is, the later the pre-warning signal is sent.</p> <p>When the accumulative output current of the AC drive is greater than the product of overload inverse time-lag curve multiplied by bE.02, the output function 9 (motor overload pre-warning) becomes active.</p>	50% to 100%	80%
bE.03	Overvoltage stall gain	<p>When the DC bus voltage exceeds the overvoltage stall protective voltage during deceleration of the AC drive, the AC drive stops deceleration and keeps the present running frequency. After the bus voltage drops, the AC drive continues to decelerate. The overvoltage stall gain is used to adjust the overvoltage suppression capacity of the AC drive.</p> <p>The larger the value is, the greater the overvoltage suppression capacity will be. The value should be kept as small as possible as long as overvoltage does not occur.</p> <p>For small-inertia load, the overvoltage stall gain should be small, because a large gain slows dynamic response of the system. For large-inertia load, the overvoltage stall gain should be large, because a small gain cannot achieve good overvoltage suppression effect.</p> <p>When it is set to 0, the overvoltage stall function is disabled. This function is invalid for the hoisting mechanism (A0.08 = 0).</p>	0-100	0
bE.04	Overvoltage stall protective voltage	<p>The larger the value is, the greater the overvoltage suppression capacity will be. The value should be kept as small as possible as long as overvoltage does not occur.</p> <p>For small-inertia load, the overvoltage stall gain should be small, because a large gain slows dynamic response of the system. For large-inertia load, the overvoltage stall gain should be large, because a small gain cannot achieve good overvoltage suppression effect.</p> <p>When it is set to 0, the overvoltage stall function is disabled. This function is invalid for the hoisting mechanism (A0.08 = 0).</p>	330 V to 800 V	<p>Three-phase 380 to 480 V models: 670 V</p> <p>Three-phase 200 to 240 V models: 380 V</p>

6 Parameter Table

Parameter No.	Parameter Name	Description	Value Range	Default
bE.05	Overcurrent stall gain	When the output current exceeds the overcurrent stall protective current during acceleration/ deceleration of the AC drive, the AC drive stops acceleration/deceleration and keeps the current frequency. After the output current decreases, the AC drive continues acceleration/deceleration.	0-100	20
bE.06	Overcurrent stall protective current	The overcurrent stall gain is used to adjust the overcurrent suppression capacity of the AC drive during acceleration/deceleration. The larger the value is, the greater the overcurrent suppression capacity will be. The value should be kept as small as possible as long as overcurrent does not occur. For small-inertia load, the overcurrent stall gain should be small, because a large gain slows dynamic response of the system. For large-inertia load, the overcurrent stall gain should be large, because a small gain cannot achieve good overcurrent suppression effect. When it is set to 0, the overcurrent stall function is disabled. bE.05 and bE.06 are valid only in V/F control mode.	100% to 200%	150%
bE.07	Detection of short-circuit to ground upon power-on	This function is used to check whether the motor is short-circuited to the ground after the AC drive is powered on. If this function is enabled, the AC drive's U, V, W terminals will have voltage output for a while after power-on. 0: Detection of short-circuit to ground upon power-on disabled 1: Detection of short-circuit to ground upon power-on enabled	0-1	1
bE.08	Input phase loss protection	This parameter determines whether to enable input phase loss protection. 0: Input phase loss protection disabled 1: Hardware input phase loss protection enabled Note: CS710 AC drive models with power ratings lower than 18.5 kW do not support this function. 2: Both hardware and software input phase loss protection enabled 3: Software input phase loss protection enabled	0-3	2
bE.09	Output phase loss protection	1: Output phase loss protection enabled 0: Output phase loss protection disabled	0-1	1

Parameter No.	Parameter Name	Description	Value Range	Default
bE.13	Torque threshold for overload protection	<p>This parameter is used to set the overload protection triggering torque. When it is set to 0, the overload protection function is disabled.</p> <p>In forward running state, the AC drive measures the output torque when the output frequency reaches the value of b7.07 or keeps at a constant value. For details, see the description of b7.06 and b7.07. If the output torque exceeds the value of bE.13, the AC drive stops automatically and restricts forward running. The restriction is removed immediately after the AC drive starts reverse running.</p>	0.0 to 150.0%	0

6 Parameter Table

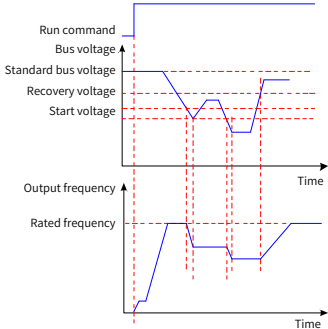
Parameter No.	Parameter Name	Description	Value Range	Default
bE.14	Power dip ride-through option	The two parameters are used to set the power dip ride-through function. The power dip ride-through function enables the AC drive to automatically reduce the output frequency to maintain full-torque output when the DC bus voltage stays low. When bE.14 is set to 1, the power dip ride-through function is enabled. When bE.14 is set to 0, this function is disabled. bE.15 is used to set the voltage for triggering power dip ride-through. This parameter sets the percentage to the standard DC bus voltage.	0-1	0
bE.15	Power dip ride-through voltage limit		70% to 95%	85%
bE.16	Built-in braking unit voltage limit	This parameter is used to set the initial voltage V _{break} triggering the action of the built-in braking unit. The value range is: $800 \geq V_{break} \geq (1.414V_s + 30)$ V _s is the input AC voltage of the AC drive. Note: If V _{break} is not set properly, the built-in braking unit may not run normally.	330-800 V	Three-phase 380 to 480 V models: 660 V Three-phase 200 to 240 V models: 370 V
bE.17	Contactors fault detection option	When this parameter is set to 1, contactor fault (17#) detection is enabled. When it is set to 0, contactor fault detection is disabled. Note: CS710 AC drive models with power ratings lower than 18.5 kW do not support this function.	0-1	1

Parameter No.	Parameter Name	Description	Value Range	Default
Group bF: Auxiliary parameters in the level-2 menu				
bF.00	Level-2 menu password	This parameter is used to set the password for displaying and modifying level-2 menu parameters. If this parameter is set to a non-zero value, you must enter the password before entering the level-2 menu. If you enter wrong passwords consecutively three times, all menus are locked. In this case, you must power off and restart the AC drive. After this parameter is set to 0, the password is canceled.	0-65535	0
bF.01	Restore factory settings in the level-2 menu	0: No operation 1: Restore factory settings in the level-2 menu b0.02 to b0.03, b2.00 to b2.02, b7.10 to b7.11, and bF.00 in the level-2 menu cannot be restored to factory settings. 2: Restore factory settings in the level-1 and level-2 menus	0-2	0
bF.02	Display user-defined parameter settings in the level-2 menu	0: Display all level-2 menu parameters 1: Display only non-default parameter settings in the level-2 menu	0-1	0
bF.03	Clear historical data	0: No operation 1: Clear historical data When this parameter is set to 1, all parameters stored upon power failure and fault records (parameters of groups E* and U1) are deleted.	0-1	0

6 Parameter Table

Parameter No.	Parameter Name	Description	Value Range	Default
bF.04	Command source option	<p>This parameter determines the input channel of AC drive control commands, including start, stop, forward, reverse, and jog commands.</p> <p>0: Operating panel control (LOCAL/REMOT indicator off) The commands are given by pressing the RUN and STOP/RES keys on the operating panel. When the operating panel is used as the input channel of AC drive control commands, all input/output terminals and the brake control time sequence are invalid. When the AC drive receives the RUN command, output function 1 (brake control) takes effect. When the AC drive receives the STOP command, it decelerates to the brake applying frequency (b6.05), and then stops output. Output function 1 becomes inactive.</p> <p>1: Terminal control (LOCAL/REMOT indicator on) AC drive control commands are given through terminal input functions 1 (Forward RUN), 2 (Reverse RUN).</p> <p>2: Communication control (LOCAL/REMOT indicator blinking) AC drive control commands are given by a host controller, PLC, or touch screen through serial communication.</p>	0-2	0
bF.05	Running frequency in operating panel control	<p>This parameter is used to set the target running frequency of the AC drive when bF.04 (command source option) is set to 0.</p>	Minimum frequency (b1.03) to maximum frequency (b1.02)	50.00 Hz
bF.06	Running direction option	<p>You can use this parameter to change the motor rotation direction without changing the motor wiring. Modifying this parameter is equivalent to swapping any two of the motor's U, V, and W wires. The motor will resume running in the original direction after parameter initialization. Do not use this function if changing the motor rotation direction is prohibited after system commissioning.</p> <p>0: Same direction 1: Reverse direction</p>	0-1	0

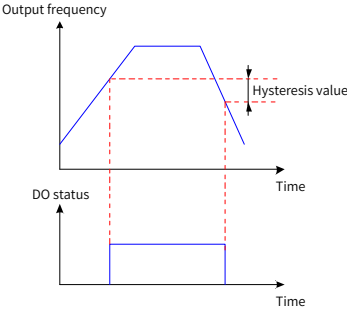
Parameter No.	Parameter Name	Description	Value Range	Default		
bF.07	Frequency detection value	When the set frequency is greater than the frequency detection value, DO function 7 (frequency reached) of the AC drive becomes active. When the set frequency is lower than the detection value minus the hysteresis value, DO function 7 is inactive. bF.07 sets the detection value, and bF.08 sets the hysteresis level (percentage to the value of bF.07).	Minimum frequency (b1.03) to maximum frequency (b1.02)	50.00 Hz		
bF.08	Frequency detection hysteresis value	 <p>Output frequency</p> <p>DO status</p> <p>Time</p> <p>Hysteresis value</p>	0.0 to 100.0%	5.0%		
bF.09	Cooling fan working mode	This parameter is used to set the working mode of the cooling fan. 0: Working when the AC drive is running The fan keeps working when the AC drive is running. After the AC drive stops, the fan works if the heatsink temperature is higher than 40°C, and stops working if the heatsink temperature is lower than 40°C. 1: Working continuously after power-on	0–1	0		
bF.10	Fault protection action 1	These parameters determine the fault level of errors 41# to 65#. The value of each parameter is a 5-digit number, representing levels of five faults. The following table lists the mapping between digits and faults.	11111–55555	11115		
bF.11	Fault protection action 2			11111		
bF.12	Fault protection action 3			Parameter	Position	Meaning
				bF.10	Ten thousands position	Level of error 41#
bF.13	Fault protection action 4			bF.10	Thousands position	Level of error 42#
			
bF.14	Fault protection action 5			bF.10	Ones position	Level of error 45#
		bF.11	Ten thousands position	Level of error 46#		
			
		bF.11	Ones position	Level of error 50#		
			
...				
bF.14	Ten thousands position	Level of error 61#				
...				
bF.14	Ones position	Level of error 65#				

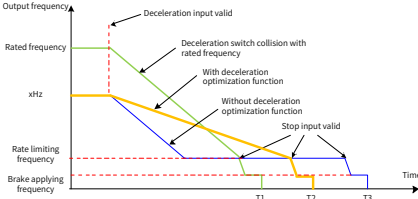
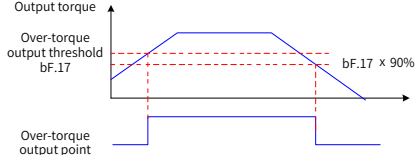
Parameter No.	Parameter Name	Description	Value Range	Default
bF.16	Deceleration frequency limit	<p>When the deceleration switch (input functions 24 and 25) is on, the output frequency of the AC drive is limited below the value of bF.16. After the stop switch (input functions 22 and 23) is on, the AC drive performs a quick stop.</p> <p>bF.15 sets the deceleration mode after the deceleration switch turns on.</p> <p>0: Deceleration optimization disabled The AC drive decelerates normally based on the deceleration time set by group b4 parameters.</p> <p>1: Deceleration optimization enabled After the deceleration switch turns on, the AC drive recalculates the optimal deceleration time based on the deceleration distance from the rated frequency to the frequency set by bF.16. This minimizes the running time during the deceleration process.</p> 	Minimum frequency (b1.03) to rated frequency (A0.04)	5.00 Hz
bF.17	Over-torque output threshold	<p>This parameter is used together with output function 12. When the output torque reaches the threshold set by this parameter, output function 12 becomes active. When the output torque falls below 90% of the threshold, output function 12 becomes inactive.</p> <p>In vector control mode, the AC drive controls output function 12 based on the output torque.</p> <p>In V/F control mode, the AC drive controls this function based on the percentage of the output current to the rated current of the motor.</p> <p>When this parameter is set to 0, output function 12 is invalid.</p> 	0.0 to 200.0%	0.0%

Parameter No.	Parameter Name	Description	Value Range	Default
bF.18	Crane process card option	This parameter determines whether the AC drive uses a crane process card (CS70CF*). If the AC drive uses a crane process card, you must set this parameter. Otherwise, the crane process card cannot work normally. 0: Crane process card not used 1: Crane process card used	0-1	0
bF.19	Running mode option	0: Application mode This parameter must be set to 0 for normal use of the AC drive. 1: Commissioning mode The commissioning mode is used for AC drive or control cabinet inspection before delivery. This mode shields functions such as brake release time sequence and output phase loss protection, and uses the V/F control mode forcibly. The parameter value restores to 0 automatically after the AC drive is powered on.	0-1	0
bF.20	Constant power function option	0: Constant power function disabled 1: Constant power function enabled	0-1	1
bF.21	Motor fan control delay	This parameter is used together with output function 13. For details, see the description of output function 13.	0 to 3000s	30s

6 Parameter Table

Groups E0 to E9 display fault information. Each group of parameters indicates a fault record. Group E0 displays information about the latest fault, and group E9 displays information about the earliest fault. All groups display the information using the same structure. Parameters of group E* cannot be modified and are retentive at power failures.

Parameter	Name	Minimum Unit	Description
E*.00	Error code	0.01	The five digits on the operating panel are numbered 5, 4, 3, 2, and 1 from left to right. Take the display of 104.01 as an example. Digits 5, 4, and 3 show the error code, in which 1 on digit 5 indicates the fault level, and 04 on digits 4 and 3 indicate the error code. Digits 2 and 1 are reserved by the manufacturer.
E*.01	Frequency reference upon fault	Operating panel display: 0.1Hz Display on computer (communication control): 0.01Hz	Displays the value of U0.00 when a fault occurs.
E*.02	Feedback reference upon fault	Operating panel display: 0.1Hz Display on computer (communication control): 0.01Hz	Displays the value of U0.01 when a fault occurs. (In V/F control mode, it displays the value of U0.00.)
E*.03	Output current upon fault	0.01 A	Displays the value of U0.03 when a fault occurs.
E*.04	Output voltage upon fault	1 V	Displays the value of U0.04 when a fault occurs.
E*.05	Output power upon fault	0.1%	Displays the value of U0.05 when a fault occurs.
E*.06	Output torque upon fault	0.1%	Displays the value of U0.06 when a fault occurs.
E*.07	Bus voltage upon fault	0.1 V	Displays the value of U0.07 when a fault occurs.

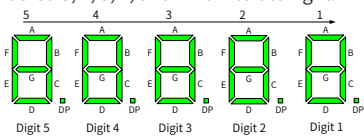
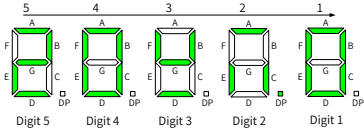
Parameter	Name	Minimum Unit	Description
E*.08	State of input functions 1 to 16 upon fault	1	<p>These four parameters indicate the states of input and output functions. Each parameter can indicate the states of 16 input or output functions with its digits and segments. When you select a parameter, its decimal value is displayed on the operating panel. Press Δ to switch the user view mode. In this mode:</p> <p>The five digits on the operating panel are numbered 5, 4, 3, 2, and 1 from left to right.</p>
E*.09	State of DI functions 17 to 32 upon fault	1	 <p>Digits 5 and 4 show the number of the current input/output function. Digit 1 shows validity of this function (0: inactive; 1: active). You can press Δ and ∇ to change the input/output function number. Functions 2 and 3 show the states of 16 functions in different segments. Digits 1-8 map to segments A-DP of digit 2, and digits 8-16 map to segments A-DP of digit 3. Example:</p>
E*.10	State of input functions 33 to 48 upon fault	1	
E*.11	State of DO functions 1 to 16 upon fault	1	 <p>In this figure, the display shows the state (digits 5 and 4) of input function 20, which is inactive (digit 1). Among input functions 17-32, functions 17, 19, 21, 24, 26, 28, 30, and 31 are active, and the others are inactive (according to digits 2 and 3).</p>
E*.12	Running step upon fault	1	<p>This parameter records the step performed in the AC drive when a fault occurs. For details, see the description of U0.26.</p>

6 Parameter Table

Parameter	Name	Minimum Unit	Description																		
E*.13	Control mode upon fault	1	<p>This parameter records settings of the command source, frequency source, and control mode when a fault occurs.</p> <table border="1"> <thead> <tr> <th>Digit</th> <th>Meaning</th> <th>Description</th> </tr> </thead> <tbody> <tr> <td>Ten thousands position</td> <td>Reserved</td> <td></td> </tr> <tr> <td>Thousands position</td> <td>Reserved</td> <td></td> </tr> <tr> <td>Hundreds position</td> <td>Command source</td> <td>See description of bF.04</td> </tr> <tr> <td>Tens position</td> <td>Frequency source</td> <td>See description of A0.07</td> </tr> <tr> <td>Ones position</td> <td>Drive control mode</td> <td>See description of b1.00</td> </tr> </tbody> </table>	Digit	Meaning	Description	Ten thousands position	Reserved		Thousands position	Reserved		Hundreds position	Command source	See description of bF.04	Tens position	Frequency source	See description of A0.07	Ones position	Drive control mode	See description of b1.00
				Digit	Meaning	Description															
				Ten thousands position	Reserved																
				Thousands position	Reserved																
				Hundreds position	Command source	See description of bF.04															
				Tens position	Frequency source	See description of A0.07															
Ones position	Drive control mode	See description of b1.00																			
E*.15	Synchronization frequency upon fault	Operating panel display: 0.1 Hz Display on computer (communication control): 0.01 Hz	This parameter records the instant value of synchronization frequency displayed on the operating panel when a fault occurs.																		
E*.16	Braking transistor current upon fault	0.01 A	This parameter records the instantaneous current of the braking transistor when a braking transistor overload fault (15#) occurs.																		
E*.17	Accumulative running time upon fault	1 h	This parameter records the value of the monitoring parameter U1.05 when a fault occurs.																		
E*.18	Accumulative power-on time upon fault	1 h	This parameter records the value of the monitoring parameter U1.06 when a fault occurs.																		

Parameters of groups U0 and U1 show real-time monitoring information of the AC drive. Values of group U0 parameters are updated in real time and will be lost after a power failure. Group U1 parameters record accumulative information and are saved upon power failures.

Parameter	Name	Minimum Unit	Description
U0.00	Frequency reference	Operating panel display: 0.1 Hz Display on computer (communication control): 0.01 Hz	It displays the frequency set for the AC drive.

Parameter	Name	Minimum Unit	Description
U0.01	Feedback frequency	Operating panel display: 0.1 Hz Display on computer (communication control): 0.01 Hz	It displays the feedback value of the actual motor running frequency. If the AC drive runs without an encoder, this parameter shows the feedback frequency calculated by the AC drive software. When the AC drive runs with an encoder, this parameter shows the actual motor running frequency provided by the encoder. If you cannot determine whether the encoder circuit is functioning normally during equipment commissioning, you can check this parameter in V/F control mode to determine whether the feedback frequency is normal. If the feedback frequency is normal, the encoder circuit works normally.
U0.02	Target frequency	Operating panel display: 0.1 Hz Display on computer (communication control): 0.01 Hz	It displays the final frequency of the AC drive in this running process.
U0.03	Output current	0.01 A	It displays the output current of the running AC drive.
U0.04	Output voltage	1 V	It displays the output voltage of the running AC drive.
U0.05	Output power	0.1%	It displays the output power of the running AC drive.
U0.06	Output torque	0.1%	It displays the output torque (percentage to the rated torque of the motor) of the running AC drive.
U0.07	Bus voltage	0.1 V	It displays the bus voltage of the AC drive.
U0.08	Higher bits of position data	1	These two parameters display the current position of the hoisting mechanism, that is, accumulative number of pulses/b7.10. U0.08 shows the higher 16 bits (with negative or positive signs) of the current position, and U0.09 shows the lower 16 bits (only positive values) of the current position. For details, see the description of b7.10 and b7.11.
U0.09	Lower bits of position data	1	
U0.10	DI state	1	It displays the DI state on the AC drive. The display mode is the same as that of E*.08-11.
U0.11	DO state	1	It displays the DO state on the AC drive. The display mode is the same as that of E*.08-11.
U0.12	AI1 voltage	0.01V	It displays the input voltage of AI1 terminal on the AC drive.
U0.13	AI2 voltage	0.01V	It displays the input voltage of AI2 terminal on the AC drive.
U0.15	AO1 output voltage	0.01V	It displays the output voltage of AO1 terminal on the AC drive.
U0.16	AO2 output voltage	0.01V	It displays the output voltage of AO2 terminal on the AC drive.

6 Parameter Table

Parameter	Name	Minimum Unit	Description																																				
U0.19	CAN communication quality	1%	It displays the CAN communication quality between the AC drive extension card and an external device. The AC drive detects the communication quality every time after it sends 100 data frames.																																				
U0.20	SPI communication quality	1%	It displays the communication quality between the AC drive and the process card. The AC drive detects the communication quality every time after it sends 100 data frames.																																				
U0.23	IGBT temperature	1°C	It displays temperature of the insulated gate bipolar transistor (IGBT) in the inverter.																																				
U0.24	Function software version	0.01	It displays the version of the AC drive's function software.																																				
U0.25	Performance software version	0.01	It displays the version of the AC drive's performance software.																																				
U0.26	AC drive internal state	1	<p>It displays the running procedure in the AC drive, which helps you in equipment commissioning and fault location. The digits are numbered 5 to 1 from left to right. The following table describes the meanings of different displays.</p> <table border="1"> <thead> <tr> <th>Digit No.</th> <th>Meaning</th> <th>Display</th> <th>Description</th> </tr> </thead> <tbody> <tr> <td>5</td> <td>Reserved</td> <td>-</td> <td>-</td> </tr> <tr> <td rowspan="2">3</td> <td rowspan="2">Brake applying procedure</td> <td>0</td> <td>Brake applying command not sent</td> </tr> <tr> <td>1</td> <td>Brake applying command sent</td> </tr> <tr> <td rowspan="2">2</td> <td rowspan="2">Brake release procedure</td> <td>0</td> <td>Brake release command not sent</td> </tr> <tr> <td>1</td> <td>Brake release command sent</td> </tr> <tr> <td rowspan="6">1</td> <td rowspan="6">Running procedure</td> <td>0</td> <td>Standby state</td> </tr> <tr> <td>1</td> <td>In brake release process</td> </tr> <tr> <td>2</td> <td>Normal running state</td> </tr> <tr> <td>3</td> <td>RUN command canceled and in brake applying process</td> </tr> <tr> <td>4</td> <td>Running under operating panel control</td> </tr> <tr> <td>6</td> <td>Motor auto-tuning state</td> </tr> <tr> <td>7</td> <td>Stopping</td> </tr> </tbody> </table>	Digit No.	Meaning	Display	Description	5	Reserved	-	-	3	Brake applying procedure	0	Brake applying command not sent	1	Brake applying command sent	2	Brake release procedure	0	Brake release command not sent	1	Brake release command sent	1	Running procedure	0	Standby state	1	In brake release process	2	Normal running state	3	RUN command canceled and in brake applying process	4	Running under operating panel control	6	Motor auto-tuning state	7	Stopping
Digit No.	Meaning	Display	Description																																				
5	Reserved	-	-																																				
3	Brake applying procedure	0	Brake applying command not sent																																				
		1	Brake applying command sent																																				
2	Brake release procedure	0	Brake release command not sent																																				
		1	Brake release command sent																																				
1	Running procedure	0	Standby state																																				
		1	In brake release process																																				
		2	Normal running state																																				
		3	RUN command canceled and in brake applying process																																				
		4	Running under operating panel control																																				
		6	Motor auto-tuning state																																				
7	Stopping																																						
U0.28	Error Code	1	It displays the error code of the fault that occurs in the AC drive.																																				
U0.29	Braking transistor current	0.01 A	It displays the output current of the braking transistor when the built-in braking unit of the AC drive is working.																																				

Parameter	Name	Minimum Unit	Description
U0.30	Maximum frequency in field weakening area	0.01 Hz	It displays the maximum frequency in the field weakening area.
U0.31	Temporary function software version	0.01	It displays the temporary function software version.
U0.32	Temporary performance software version	0.01	It displays the temporary performance software version.
U1.00	Number of emergency stops	1	It displays the total number of level-1 faults that have occurred in the AC drive.
U1.01	Number of quick stops	1	It displays the total number of level-2 and level-3 faults that have occurred in the AC drive.
U1.02	Higher bits in the number of brake operations	1	The two parameters display the total number of operations of the brake when controlled by the AC drive. When the value of lower bits reaches 65535, the value of higher bits increases by 1 and the lower bits are reset to 0.
U1.03	Lower bits in the number of brake operations	1	
U1.04	Total time used to reach the torque limit	0.1 h	It displays the total time elapsed before the output torque of the AC drive reaches or exceeds the upper limit (b1.04 and b1.05).
U1.05	Accumulative running time	1 h	It displays the total time the AC drive has been in run state.
U1.06	Accumulative power-on time	1 h	It displays the total time the AC drive has kept in power-on state.

6.3 Level-3 Menu (Group F) Parameter Table

The level-3 menu contains output performance parameters of the AC drive and manufacturer parameters. Generally, you do not need to modify parameters in this menu.

You can enter the level-3 menu only after entering the correct password set by FF.00.

6 Parameter Table

Param. No.	Parameter Name	Content	Value Range	Default														
Group F0: Motor parameters																		
F0.00	Asynchronous motor stator resistance	<p>These asynchronous motor parameters are not available on the motor nameplate and are obtained by means of motor auto-tuning. Auto-tuning mode 1 can only obtain parameters F0.00 to F0.02; auto-tuning mode 3 can obtain all the five parameters; auto-tuning mode 2 can obtain the five parameters as well as other parameters, such as the encoder phase sequence and current loop PI parameters.</p> <p>When you change the rated power of the motor (A0.01), the AC drive automatically restores values of these five parameters to commonly used settings for standard Y series asynchronous motors.</p>	(≤ 55 kW) 0.001–65.535 Ω (> 55 kW) 0.0001–6.5535 Ω	Depending on motor model														
F0.01	Asynchronous motor rotor resistance		(≤ 55 kW) 0.001–65.535 Ω (> 55 kW) 0.0001–6.5535 Ω	Depending on motor model														
F0.02	Asynchronous motor leakage inductance		(≤ 55 kW) 0.01–655.35 mH (> 55 kW) 0.001–65.535 mH	Depending on motor model														
F0.03	Asynchronous motor mutual inductance		(≤ 55 kW) 0.1–6553.5 mH (> 55 kW) 0.01–655.35 mH	Depending on motor model														
F0.04	Asynchronous motor no-load current		(≤ 55 kW) 0.01 A to A0.03 (> 55 kW) 0.1 A to A0.03	Depending on motor model														
F0.16	Carrier frequency	<p>This parameter is used to adjust the carrier frequency of the AC drive, helping to reduce the motor noise, avoiding resonance of the mechanical system, or reducing the leakage current to the ground and interference generated by the AC drive.</p> <p>When the carrier frequency is low, the output current higher order harmonics increase, causing high power loss and temperature rise of the motor.</p> <p>When the carrier frequency is high, the power loss and temperature rise of the motor is reduced, but the power loss, temperature rise and interference of the AC drive increase.</p> <p>The carrier frequency affects the performance of the AC drive and motor in the following way:</p> <table border="1" style="margin-left: auto; margin-right: auto;"> <tr> <td>Carrier frequency</td> <td>Low → high</td> </tr> <tr> <td>Motor noise</td> <td>High → low</td> </tr> <tr> <td>Output current waveform</td> <td>Bad → good</td> </tr> <tr> <td>Motor temperature rise</td> <td>High → low</td> </tr> <tr> <td>Drive temperature rise</td> <td>Low → high</td> </tr> <tr> <td>Leakage current</td> <td>Small → large</td> </tr> <tr> <td>Radiation interference</td> <td>Small → large</td> </tr> </table>	Carrier frequency	Low → high	Motor noise	High → low	Output current waveform	Bad → good	Motor temperature rise	High → low	Drive temperature rise	Low → high	Leakage current	Small → large	Radiation interference	Small → large	1.0–12.0 kHz	Depending on drive model
Carrier frequency	Low → high																	
Motor noise	High → low																	
Output current waveform	Bad → good																	
Motor temperature rise	High → low																	
Drive temperature rise	Low → high																	
Leakage current	Small → large																	
Radiation interference	Small → large																	

Param. No.	Parameter Name	Content	Value Range	Default
Group F1: Vector control parameters				
F1.00	Speed loop proportional gain 1	Speed loop PI parameters vary with running frequencies of the AC drive. If the running frequency is smaller than switchover frequency 1 (F1.02), speed loop PI parameters F1.00 and F1.01 are used. If the running frequency is greater than the switchover frequency 2 (F1.05), speed loop PI parameters F1.03 and F1.04 are used. If the running frequency is between switchover frequency 1 and switchover frequency 2, the speed loop PI parameters are obtained from linear switchover between the two groups of PI parameters. By setting the proportional gain and integral time of the speed regulator, you can adjust the dynamic response to speed changes in vector control. Increasing the proportional gain or reducing the integral time can speed up dynamic response of the speed loop. However, too large proportional gain or too small integral time may cause system oscillation. We recommend that you adjust these parameters as follows: If the default setting cannot meet your requirements, fine tune the factory settings. First increase the proportional gain to prevent system oscillation, and then reduce the integral time to ensure quick response of the system and small overshoot. Caution: Improper PI parameter settings may cause high speed overshoot. Even worse, overvoltage may occur when overshoot drops.	1 to 100	60
F1.01	Speed loop integral time 1		0.01s to 10.00s	0.50s
F1.02	Switchover frequency 1		0.00 Hz to F1.05	5.00 Hz
F1.03	Speed loop proportional gain 2		1 to 100	20
F1.04	Speed loop integral time 2		0.01s to 10.00s	1.00s
F1.05	Switchover frequency 2	F1.02 to b1.02	10.00 Hz	
F1.06	Time constant of speed loop filter	In vector control mode, the output of the speed loop regulator is torque current reference. This parameter is used to filter the torque current reference. Normally, it is not required to adjust this parameter and can be increased in the case of large speed fluctuation. In the case of motor oscillation, decrease the value of this parameter properly. A small time constant may lead to large fluctuation of the output torque but can ensure quick response.	0.000s to 1.000s	0.070s

6 Parameter Table

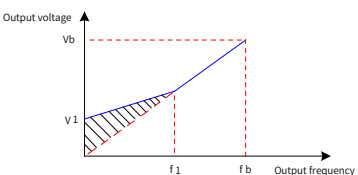
Param. No.	Parameter Name	Content	Value Range	Default
F1.08	Excitation adjustment proportional gain	<p>They are current loop PI parameters for vector control. Their values are automatically obtained after the asynchronous motor completes auto-tuning mode 2, and do not need to be changed.</p> <p>Note that the current loop integral regulator sets the integral gain directly and does not use the integral time as the dimension. If the current loop PI gain is too large, the entire control loop may oscillate. Therefore, when you find large current oscillation or torque fluctuation, decrease the values of the proportional gain or integral gain.</p>	0–20000	2000
F1.09	Excitation adjustment integral gain		0–20000	1300
F1.10	Torque adjustment proportional gain		0–20000	2000
F1.11	Torque adjustment integral gain		0–20000	1300
Group F2: V/F control parameters				
F2.01	Torque boost	<p>To compensate for the low frequency torque of V/F control, you can boost the output voltage of the AC drive running at low frequency. If the torque boost is too large, the motor may overheat and overcurrent may occur on the AC drive.</p> <p>If the motor is connected to heavy load but does not have sufficient startup torque, increase the torque boost. If the motor is connected to light load, decrease the torque boost.</p>	0.0% to 30.0%	Depending on motor power
F2.02	Cutoff frequency of torque boost	<p>If the torque boost is set to 0.0, the AC drive automatically calculates the torque boost value based on motor parameters such the stator resistance.</p> <p>Cutoff frequency of torque boost: Torque boost is valid when the running frequency within this value and becomes invalid when the running frequency exceeds this value.</p>  <p>V1: Manual torque boost voltage Vb: Max. output voltage f1: Manual torque boost cutoff frequency fb: Rated frequency</p>	0.00 Hz–b1.02	50.00 Hz

Param. No.	Parameter Name	Content	Value Range	Default
F2.09	V/F slip compensation gain	<p>This parameter is valid only for asynchronous motors.</p> <p>It can compensate for the speed slip of an asynchronous motor when the load increases, reducing the variation in the motor speed in case of load change.</p> <p>If the V/F slip compensation gain is set to 100%, the slip compensation applied to the motor with the rated load is the rated motor slip. The AC drive automatically calculates the rated motor slip based on the motor's rated frequency and rated speed set by group F1 parameters.</p> <p>When adjusting the V/F slip compensation gain, check that the motor speed under the rated load is the same as the target motor speed. If the motor speed is different from the target speed, fine tune this parameter.</p>	0.0% to 100.0%	0.0%
F2.10	V/F over-excitation gain	<p>Over-excitation control can suppress the rise of the DC bus voltage during deceleration of the AC drive, preventing overvoltage incidents. A larger over-excitation gain results in a better suppression effect.</p> <p>Increase the over-excitation gain if the AC drive is liable to overvoltage during deceleration. However, the output current will increase if the over-excitation gain is too large. Set this parameter to a proper value in actual applications.</p> <p>Set the over-excitation gain to 0 in the following conditions:</p> <ol style="list-style-type: none"> 1. The inertia is small and the DC bus voltage will not rise during motor deceleration. 2. The AC drive has a braking resistor. 	0-200	0
F2.11	Oscillation suppression gain	<p>To avoid negative influence on V/F control, keep this gain as small as possible while ensuring efficient oscillation suppression.</p> <p>Set this parameter to 0 if the motor has no oscillation. Increase the gain properly only when the motor has obvious oscillation. The larger the value is, the better the oscillation suppression result will be.</p> <p>When oscillation suppression is enabled, the motor's rated current and no-load current must be accurate. Otherwise, the V/F oscillation suppression effect will not be satisfactory.</p>	0-100	40

6 Parameter Table

Param. No.	Parameter Name	Content	Value Range	Default
Group F3: Control optimization parameters				
F3.00	DPWM switchover frequency upper limit	<p>This parameter determines the wave modulation mode of an asynchronous motor. If the running frequency of the AC drive is lower than the upper limit, the waveform is 7-segment continuous modulation. If the running frequency is higher than the upper limit, the waveform is 5-segment intermittent modulation.</p> <p>In the 7-segment continuous modulation pattern, the switching loss is large but the current ripple is small. In the 5-segment intermittent modulation pattern, the switching loss is small but the current ripple is large. This pattern may lead to instability of the motor at high frequency. Do not modify this parameter in normal conditions.</p> <p>For details about AC drive loss and temperature rise, see the description of F0.16.</p>	0.00 Hz to maximum frequency (b1.02)	12.00 Hz
F3.01	PWM modulation mode	<p>This parameter is valid only for V/F control. In synchronous modulation mode, the carrier frequency changes linearly with the output frequency, so the ratio between them (carrier ratio) remains unchanged. This modulation mode is generally used at high output frequency, which helps improve the output voltage quality.</p> <p>Synchronous modulation is not required at low output frequency (100 Hz or lower). This is because asynchronous modulation is preferred when the ratio of carrier frequency to output frequency is high.</p> <p>Synchronous modulation takes effect only when the frequency reference is higher than 85 Hz. Asynchronous modulation is used when the frequency reference is below 85 Hz.</p> <p>0: Asynchronous modulation 1: Synchronous modulation</p>	0-1	0
F3.02	Dead zone compensation mode	<p>Generally, this parameter does not need to be modified. You need to try a different compensation mode only when there is any special requirement on the waveform quality of the output voltage or when oscillation occurs on the motor. Mode 2 is recommended for high-power drives.</p> <p>0: No compensation 1: Compensation mode 1 2: Compensation mode 2</p>	0-2	1



Param. No.	Parameter Name	Content	Value Range	Default
F3.03	Random PWM depth	Random PWM can smooth noise of the motor and reduce electromagnetic interference. If this parameter is set to 0, random PWM is disabled. Different random PWM depths bring different results. 0: Random PWM disabled 1-10: Random PWM depth values	0-10	0
F3.04	Rapid current limiting	Rapid current limiting minimizes risks of overcurrent, ensuring uninterrupted running of the AC drive. However, if the AC drive stays in the current limiting state for a long time, it may be damaged due to high temperature or other reasons. To prevent this problem, the AC drive reports error 40# (pulse-by-pulse current limiting) if current limiting lasts for a long time. This error indicates that the AC drive is overloaded and needs to stop. 0: Disabled 1: Enabled	0-1	1
F3.05	Current detection compensation	This parameter is used to set the current detection compensation for the AC drive. If the compensation value is too large, the control performance may deteriorate. Do not change the value of this parameter in normal conditions.	0-100	5
F3.06	Undervoltage threshold	This parameter is used to set the voltage value for triggering an undervoltage error (09#). When the DC bus voltage falls below this value, the AC drive changes to the undervoltage state and stops running.	140-630 V	Three-phase 380 to 480 V models: 350 V Three-phase 200 to 240 V models: 200 V
Group FF: Auxiliary parameters in the level-3 menu				
FF.00	Level-3 menu password	This parameter is used to set the password for displaying and modifying level-3 menu parameters. If this parameter is set to a non-zero value, you must enter the password before entering the level-3 menu. If you enter wrong passwords consecutively three times, all menus are locked. In this case, you must power off and restart the AC drive. After this parameter is set to 0, the password is canceled.	0-65535	0

6 Parameter Table

Param. No.	Parameter Name	Content	Value Range	Default
FF.10	Restore factory settings in the level-3 menu	<p>0: No operation</p> <p>1: Restore factory settings in the level-3 menu</p> <p>Parameters F0.00-04, F0.16, F2.01, F2.11, and FF.00 in the level-1 menu cannot restore to factory settings.</p> <p>2: Restore factory settings of all parameters</p>	0-2	0
FF.11	Display user-defined parameter settings in the level-3 menu	<p>0: Display all level-3 menu parameters</p> <p>1: Display only non-default parameter settings in the level-3 menu</p>	0-1	0

7 Troubleshooting

7.1 Safety Information

 Danger	<ul style="list-style-type: none"> ◆ Perform wiring only when the power is disconnected (all breakers must be shut off). Failure to comply may result in electric shock.
 Warning	<ul style="list-style-type: none"> ◆ Make sure to ground the AC drive according to local laws and regulations. Failure to comply may result in electric shock or a fire. ◆ Do not remove the front cover or touch the internal circuit while the power is on. Failure to comply may result in electric shock. ◆ Do not allow unqualified personnel to perform any maintenance, inspection or part replacement work. Failure to comply may result in electric shock or a fire. ◆ When installing the AC drive inside an enclosed cabinet, use a cooling fan or air conditioner to keep the temperature below 50°C. Failure to comply may result in overheating or even a fire. ◆ Tighten all screws based on the specified tightening torque. Failure to comply may result in a fire or electric shock. ◆ Always confirm input voltage is within nameplate rating. Failure to comply may result in electric shock or a fire. ◆ Keep flammable and combustible materials away from the AC drive.
 Caution	<ul style="list-style-type: none"> ◆ Cover the top of the AC drive with a temporary cloth or paper during installation to prevent foreign matter such as metal shavings, oil and water from falling into the AC drive. If any foreign matter falls into the AC drive, the AC drive may have a fault. ◆ After the installation is complete, remove the temporary cloth or paper. If leaving the cloth or paper on the AC drive, the AC drive may have abnormal heating due to poor ventilation. ◆ Follow proper electrostatic discharge (ESD) procedures when operating the AC drive. Failure to comply will damage the internal circuit of the AC drive.

7.2 Troubleshooting During Trial Run

1 Open-loop Vector Control (b1.00 = 0: Factory Default)

In this control mode, the AC drive controls the motor speed and torque without an encoder for speed feedback. It needs to obtain motor parameters through auto-tuning.

Problem	Solution
Overload or overcurrent detected during motor start	<ul style="list-style-type: none"> ◆ Set motor parameters (A0.01 to A0.05) according to values on the motor nameplate. ◆ Select a proper motor auto-tuning mode (b0.04) and perform motor auto-tuning.
Slow torque or speed response and motor oscillation at a frequency below 5 Hz	<ul style="list-style-type: none"> ◆ To speed up torque and speed response, increase the value of F1.00 (speed loop proportional gain) in increments of 10 or decrease the value of F1.01 (speed loop integral time) in decrements of 0.05. ◆ If motor oscillation occurs, decrease the values of F1.00 and F1.01.
Slow torque or speed response and motor oscillation at a frequency above 5 Hz	<ul style="list-style-type: none"> ◆ To speed up the torque and speed response, increase the value of F1.03 (Speed loop proportional gain) in increments of 10 or decrease the value of F1.04 (Speed loop integral time) in decrements of 0.05. ◆ If motor oscillation occurs, decrease the values of F1.03 and F1.04.
Low speed accuracy	<ul style="list-style-type: none"> ◆ If there is a large deviation in the motor's load speed, increase the value of b1.01 (slip compensation gain) in increments of 10%.
Obvious speed fluctuation	<ul style="list-style-type: none"> ◆ If the motor speed fluctuates severely, increase the value of F1.06 (speed filter time) with increments of 0.001s.
Loud motor noise	<ul style="list-style-type: none"> ◆ Increase the value of F0.16 (carrier frequency) in increments of 1.0 kHz. Note that increasing the carrier frequency will result in an increase in the leakage current of the motor and cable.
Insufficient motor torque	<ul style="list-style-type: none"> ◆ Check whether the torque upper limit is small. If so, increase the torque upper limit (b1.04 and b1.05) in frequency control mode or increase the torque reference in torque control mode.

2 Closed-Loop Vector Control (b1.00 = 1)

This mode can be used when the AC drive can receive speed feedback from an encoder. In this mode, you need to set the encoder's pulses per revolution, type, and signal direction correctly.

Problem	Solution
Overload or overcurrent detected during motor start	<ul style="list-style-type: none"> ◆ Set the encoder's pulses per revolution, type, and signal direction correctly.
Overload or overcurrent detected when the motor is running	<ul style="list-style-type: none"> ◆ Set motor parameters (A0.01 to A0.05) according to values on the motor nameplate. ◆ Select a proper motor auto-tuning mode (b0.04) and perform motor auto-tuning.
Slow torque or speed response and motor oscillation at a frequency below 5 Hz	<ul style="list-style-type: none"> ◆ To speed up torque and speed response, increase the value of F1.00 (Speed loop proportional gain) in increments of 10 or decrease the value of F1.01 (Speed loop integral time) in decrements of 0.05. ◆ If motor oscillation occurs, decrease the values of F1.00 and F1.01.

Problem	Solution
Slow torque or speed response and motor oscillation at a frequency above 5 Hz	<ul style="list-style-type: none"> ◆ To speed up torque and speed response, increase the value of F1.03 (Speed loop proportional gain) in increments of 10 or decrease the value of F1.04 (Speed loop integral time) in decrements of 0.05. ◆ If motor oscillation occurs, decrease the values of F1.03 and F1.04.
Obvious speed fluctuation	<ul style="list-style-type: none"> ◆ If the motor speed fluctuates severely, increase the value of F1.06 (Speed filter time) in increments of 0.001s.
Loud motor noise	<ul style="list-style-type: none"> ◆ Increase the value of F0.16 (Carrier frequency) with increments of 1.0 kHz. Note that increasing the carrier frequency will result in an increase in the leakage current of the motor and cable.
Insufficient motor torque	<ul style="list-style-type: none"> ◆ Check whether the torque upper limit is small. If so, increase the torque upper limit (b1.04 and b1.05) in frequency control mode or increase the torque reference in torque control mode.

3 V/F Control (b1.00 = 2)

This mode is used when the motor has no encoder to provide speed feedback. You need to set only the rated voltage and rated frequency of the motor correctly.

Problem	Solution
Oscillation of the running motor	<ul style="list-style-type: none"> ◆ Increase the value of F2.11 (V/F oscillation suppression gain) in increments of 10. The permissible maximum value of this parameter is 100.
Overcurrent during high-power start	<ul style="list-style-type: none"> ◆ Decrease the value of F2.01 (Torque boost) in decrements of 0.5%.
Large current in running	<ul style="list-style-type: none"> ◆ Set the rated voltage (A0.02) and rated frequency (A0.04) of the motor correctly. ◆ Decrease the value of F2.01 (Torque boost) in decrements of 0.5%.
Loud motor noise	<ul style="list-style-type: none"> ◆ Increase the value of F0.16 (Carrier frequency) in increments of 1.0 kHz. Note that increasing the carrier frequency will result in an increase in the leakage current of the motor and cable.

7.3 Fault Display

The CS710 AC drive monitors various input signals, running conditions, and external feedback in real time. Once a fault occurs, the AC drive takes the corresponding protection action, and the operating panel displays fault information, such as "Er 102".

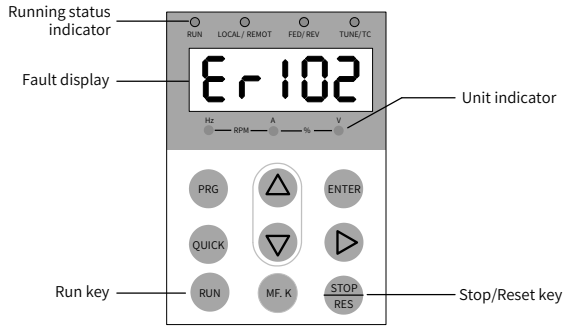

Figure 7-1 Fault display

The five digits on the operating panel are numbered 5, 4, 3, 2, and 1 from left to right. Take the display of 103.02 as an example. Digits 5, 4, and 3 show the error code, in which 1 on digit 5 indicates the fault level, and 03 on digits 4 and 3 indicates the error code. 02 on digits 2 and 1 indicates the error sub-code, which is reserved by the manufacturer. You can obtain fault information by checking E* group parameters. The following figure shows the display in this example.

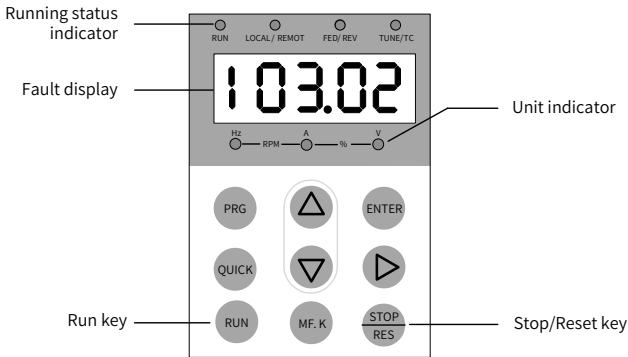
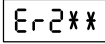
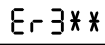
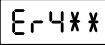



Figure 7-2 LED display of a fault

Before seeking help, find the possible causes and rectify the fault according to instructions in this chapter.

The CS710 series AC drive is the core of a crane's electronic control system. Fault information provided by the AC drive is graded into five levels based on the impact on the system. The following table describes responses of the AC drive to different levels.

Fault Level	Response	Display
Level 1	<ul style="list-style-type: none"> ◆ The operating panel displays the error code. ◆ Output function 1 (brake control) is inactive. ◆ Output function 2 (stop upon fault) is active. ◆ The AC drive performs a coast-to-stop. 	<div style="border: 1px solid black; padding: 5px; display: inline-block;">Er 1**</div>

Fault Level	Response	Display
Level 2	<ul style="list-style-type: none"> ◆ The operating panel displays the error code. ◆ Output function 3 (fault alarm) is active. ◆ The AC drive performs a quick stop. 	
Level 3	<ul style="list-style-type: none"> ◆ The operating panel displays the error code. ◆ Output function 3 (fault alarm) is active. ◆ The AC drive performs a decelerate-to-stop. 	
Level 4	<ul style="list-style-type: none"> ◆ The operating panel displays the error code. ◆ Output function 4 (fault message) is active. ◆ System operation is not affected. 	
Level 5	<ul style="list-style-type: none"> ◆ System operation is not affected. 	

**NOTE**

- ◆ Faults with error codes 1# to 40# are driving performance faults and are graded level 1 by default. Their fault level cannot be changed.
- ◆ Faults with error codes 41# to 65# are AC drive function faults. You can change their fault levels by setting parameters bF.10 to bF.14. (See the description of bF.10 to bF.14.)

7.4 Reset upon Fault

Stage	Solution	Remarks
When the fault occurs	Check fault information on the operating panel.	View groups E0 to E9. 
Before reset	Find the cause of the fault based on the fault type displayed on the operating panel and rectify the fault. Then reset the AC drive.	Troubleshoot the fault according to " 7.5 Error Codes and Solutions ".

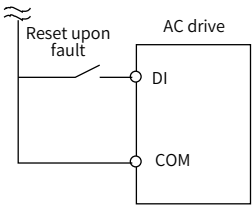
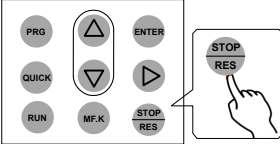
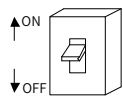
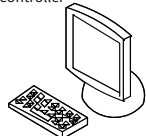
Stage	Solution	Remarks
Reset method	<p>1) Set the DI option to function 3 (b3.01-b3.10 = 3: reset upon fault). Verify that the RUN command has been canceled, in which case the reset terminal is valid.</p>	
	<p>2) Press the red reset key on the operating panel to reset the AC drive.</p>	<p>Press the reset key to reset the AC drive.</p> 
	<p>3) Power on the AC drive again for the AC drive to reset automatically. Cut off the power supply to the main circuit. When the error code on the operating panel disappears, resume the power supply.</p>	
	<p>4) Reset the AC drive on the host controller (communication control). In the communication control mode (bF.04 = 2), confirm that the RUN command has been canceled, and then set the 2000H communication address to 7 (reset upon fault), so that drive will reset after the fault is rectified.^[Note]</p>	<p>Host controller</p> 



◆ For details, see "[Appendix A Modbus Communication Protocol](#)".

7.5 Error Codes and Solutions

The following table lists the faults that may occur during use of the AC drive and solutions to these faults.

Error Code	Fault Name	Possible Cause	Solution
Er102	Overcurrent during acceleration	<ol style="list-style-type: none"> 1. The output circuit is grounded or short circuited. 2. The control mode is vector control but motor auto-tuning is not performed. 3. The acceleration time is too short. 4. Customized torque boost or V/F curve is not appropriate. 5. The voltage is too low. 6. A start command is sent to the rotating motor. 7. A load is added during acceleration. 8. The power rating of the AC drive is too low. 	<ol style="list-style-type: none"> 1. Eliminate faults of peripheral devices. 2. Perform motor auto-tuning. 3. Increase the acceleration time. 4. Adjust the customized torque boost or V/F curve. 5. Adjust the voltage to the normal range. 6. Select rotational speed tracking restart or start the motor after it stops. 7. Remove the added load. 8. Select an AC drive model of higher power rating.
Er103	Overcurrent during deceleration	<ol style="list-style-type: none"> 1. The output circuit is grounded or short circuited. 2. The control mode is vector control but motor auto-tuning is not performed. 3. The deceleration time is too short. 4. The voltage is too low. 5. A load is added during deceleration. 6. No braking unit and braking resistor are installed. 7. The braking circuit is short-circuited. 	<ol style="list-style-type: none"> 1. Eliminate faults of peripheral devices. 2. Perform motor auto-tuning. 3. Increase the deceleration time. 4. Adjust the voltage to the normal range. 5. Remove the added load. 6. Install the braking unit and braking resistor. 7. Check whether the braking resistor is faulty.
Er104	Overcurrent at constant speed	<ol style="list-style-type: none"> 1. The output circuit is grounded or short circuited. 2. The control mode is vector control but motor auto-tuning is not performed. 3. The voltage is too low. 4. A load is added when the motor is running. 5. The power rating of the AC drive is too low. 6. The braking circuit is short-circuited. 	<ol style="list-style-type: none"> 1. Eliminate faults of peripheral devices. 2. Perform motor auto-tuning. 3. Adjust the voltage to the normal range. 4. Remove the added load. 5. Select an AC drive model of higher power rating. 6. Check whether the braking resistor is faulty.

Error Code	Fault Name	Possible Cause	Solution
Er105	Overvoltage during acceleration	<ol style="list-style-type: none"> 1. The input voltage is too high. 2. An external force drives the motor during acceleration. 3. The acceleration time is too short. 4. No braking unit and braking resistor are installed. 	<ol style="list-style-type: none"> 1. Adjust the voltage to the normal range. 2. Cancel the external force or install a braking resistor. 3. Increase the acceleration time. 4. Install the braking unit and braking resistor.
Er106	Overvoltage during deceleration	<ol style="list-style-type: none"> 1. The input voltage is too high. 2. An external force drives the motor during deceleration. 3. The deceleration time is too short. 4. No braking unit and braking resistor are installed. 	<ol style="list-style-type: none"> 1. Adjust the voltage to the normal range. 2. Cancel the external force or install a braking resistor. 3. Increase the deceleration time. 4. Install the braking unit and braking resistor.
Er107	Overvoltage at constant speed	<ol style="list-style-type: none"> 1. The input voltage is too high. 2. An external force drives the motor during acceleration. 	<ol style="list-style-type: none"> 1. Adjust the voltage to the normal range. 2. Cancel the external force or install a braking resistor.
Er108	Control power fault	The input voltage is out of the specified range.	Adjust the input voltage to the specified range.
Er109	Undervoltage fault	<ol style="list-style-type: none"> 1. An instantaneous power failure occurs. 2. The input voltage is out of the allowable range. 3. The bus voltage is abnormal. 4. The rectifier bridge and pre-charge resistor are faulty. 5. The driver board is faulty. 6. The control board is faulty. 	<ol style="list-style-type: none"> 1. Reset the AC drive. 2. Adjust the voltage to the normal range. 3. Contact the agent or Inovance. 4. Contact the agent or Inovance. 5. Contact the agent or Inovance. 6. Contact the agent or Inovance.
Er110	AC drive overload	<ol style="list-style-type: none"> 1. The load is too heavy or the rotor of the motor is blocked. 2. The power rating of the AC drive is too low. 	<ol style="list-style-type: none"> 1. Reduce the load and check the motor and mechanical conditions. 2. Select an AC drive model of higher power rating.
Er111	Motor overload	<ol style="list-style-type: none"> 1. The motor protection parameter bE.01 is not set properly. 2. The load is too heavy or the rotor of the motor is blocked. 3. The power rating of the AC drive is too low. 	<ol style="list-style-type: none"> 1. Set the bE.01 properly. 2. Reduce the load and check the motor and mechanical conditions. 3. Select an AC drive model of higher power rating.

Error Code	Fault Name	Possible Cause	Solution
Er112	Input phase loss	<ol style="list-style-type: none"> 1. The three-phase power input is abnormal. 2. The driver board, lightning protection board, control board, or rectifier bridge is abnormal. 	<ol style="list-style-type: none"> 1. Check and eliminate wiring problems. 2. Contact the agent or Inovance.
Er114	IGBT overheat	<ol style="list-style-type: none"> 1. The ambient temperature is too high. 2. The cooling air channel is blocked. 3. The fan is damaged. 4. The thermistor of the module is damaged. 5. The IGBT module is faulty. 	<ol style="list-style-type: none"> 1. Lower the ambient temperature. 2. Clean the cooling air channel. 3. Replace the fan. 4. Replace the thermistor. 5. Replace the IGBT module.
Er115	Built-in braking unit overloaded	<ol style="list-style-type: none"> 1. The resistance of the braking resistor is too small. 2. The braking resistor is short circuited. 	<ol style="list-style-type: none"> 1. Use a braking resistor of larger resistance. 2. Check the connection cable between the AC drive and braking resistor. 3. Contact the agent or Inovance.
Er116	Built-in braking unit short-circuited	<ol style="list-style-type: none"> 3. The built-in braking unit is damaged. 4. The power of the load is too high. 	
Er117	Contactors fault	<ol style="list-style-type: none"> 1. The driver board or power supply is faulty. 2. The contactor is faulty. 	<ol style="list-style-type: none"> 1. Replace the driver board or power supply board. 2. Replace the contactor.
Er118	Current detection fault	<ol style="list-style-type: none"> 1. The Hall device is faulty. 2. The driver board is faulty. 	<ol style="list-style-type: none"> 1. Replace the Hall device. 2. Replace the driver board.
Er119	Motor auto-tuning fault	<ol style="list-style-type: none"> 1. The motor parameter settings are inconsistent with those on the motor nameplate. 2. Motor auto-tuning times out. 	<ol style="list-style-type: none"> 1. Set the motor parameters according to values on the motor nameplate. 2. Check the connection cable between the AC drive and the motor.
Er120	Encoder fault	<ol style="list-style-type: none"> 1. The encoder type does not match the AC drive. 2. The encoder is connected incorrectly. 3. The encoder is damaged. 4. The PG card is faulty. 	<ol style="list-style-type: none"> 1. Set the encoder type correctly. 2. Eliminate wiring problems. 3. Replace the encoder. 4. Replace the PG card.
Er123	Short circuit to ground	<ol style="list-style-type: none"> 1. The motor is short circuited to the ground. 	<ol style="list-style-type: none"> 1. Replace the cable or motor.

Error Code	Fault Name	Possible Cause	Solution
Er125	Output phase loss	<ol style="list-style-type: none"> 1. The cables connecting the AC drive and the motor are abnormal. 2. The three-phase outputs of the AC drive are unbalanced when the motor is running. 3. The driver board is faulty. 4. The IGBT module is faulty. 	<ol style="list-style-type: none"> 1. Eliminate faults of peripheral devices. 2. Check whether the motor three-phase winding is normal. If not, rectify the fault. 3. Contact the agent or Inovance. 4. Contact the agent or Inovance.
Er137	Abnormal frequency direction	The direction of the frequency reference is reverse to the direction of the motor feedback frequency.	<ol style="list-style-type: none"> 1. Check that motor parameters are set correctly. 2. Check whether the load is heavy. If so, reduce the load. 3. Modify the setting of bC.02.
Er138	Abnormal frequency following	There is large deviation between the frequency reference and the motor feedback frequency.	<ol style="list-style-type: none"> 1. Check that motor parameters are set correctly. 2. Check whether the load is heavy. If so, reduce the load. 3. Modify settings of bC.03 and bC.04.
Er140	Pulse-by-pulse current limiting fault	<ol style="list-style-type: none"> 1. The load is too heavy or the rotor of the motor is blocked. 2. The power rating of the AC drive is too low. 	<ol style="list-style-type: none"> 1. Reduce the load and check the motor and mechanical conditions. 2. Select an AC drive model of higher power rating.
Er453	Brake failure protection	If the encoder pulse feedback increases when the AC drive stops, the brake is loose. In this case, the AC drive runs at 0 Hz. This parameter is valid when b1.00 is set to 1 (FVC).	<ol style="list-style-type: none"> 1. Check whether the brake is loose. If yes, increase the braking torque or contact the manufacturer. 2. Check whether bc.00 is set correctly. If its value is too low, increase the value as required. When it is set to 0, this function is disabled.
Er*41	Brake release fault	The input brake release feedback signal is incorrect. For details, see the description of b6.08.	<ol style="list-style-type: none"> 1. Check the brake circuit. 2. Check the brake release feedback input signal (input function 11) connected to the control board.
Er*42	Brake applying fault	The input brake applying feedback signal is incorrect. For details, see the description of b6.08.	<ol style="list-style-type: none"> 1. Check the brake circuit. 2. Check the brake applying feedback input signal (input function 12) connected to the control board.

Error Code	Fault Name	Possible Cause	Solution
Er*43	Shaft-cooling motor low-speed running timeout	For details, see the description of b0.00 and b0.01.	<ol style="list-style-type: none"> 1. Adjust settings of b0.00 and b0.01. 2. Take protection measures to prevent the motor from overheating.
Er*44	Forward and reverse RUN commands valid simultaneously	The AC drive detects forward and reverse RUN commands simultaneously.	<ol style="list-style-type: none"> 1. Check peripheral circuits of the forward and reverse RUN command input signals. 2. Increase the DI filter time properly.
Er*45	Joystick not reset	The AC drive detects the RUN command or input frequency reference signal at power-on.	<ol style="list-style-type: none"> 1. Ensure that all NO inputs are disabled during power-on. 2. Enter the RUN command after system initialization is completed.
Er*46	Process card communication fault	Communication between the AC drive and process card (CS70CF*) is abnormal.	<ol style="list-style-type: none"> 1. Check that bF.18 is set correctly. 2. Contact the agent or Inovance.
Er*47	CANlink communication fault	<ol style="list-style-type: none"> 1. The CANlink extension card does not work normally. 2. The communication cable does not work normally. 	<ol style="list-style-type: none"> 1. Check that communication cables between extension cards are securely connected. 2. Check that the extension card interfaces are securely connected. 3. Shorten the distances between communication nodes.
Er*48	Communication error	<ol style="list-style-type: none"> 1. The host controller does not work normally. 2. The communication cable does not work normally. 3. Communication parameters in group bd are not set properly. 	<ol style="list-style-type: none"> 1. Check the cable connected to the host controller. 2. Check the communication cable connection. 3. Set the extension card correctly. 4. Set communication parameters correctly.
Er*49	Parameter read-write error	The EEPROM chip is damaged.	Replace the control board.
Er*50	External input fault	DI function 6 is valid.	Reset the AC drive.
Er*51	Parameter error	<ol style="list-style-type: none"> 1. A parameter is not set properly. 2. The EEPROM storage chip is faulty. 	<ol style="list-style-type: none"> 1. Use the parameter self-check function to find the abnormal function parameter and modify it. 2. Replace the control board.

7.6 Fault Symptoms and Solutions

No.	Fault Description	Possible Cause	Solution
1	There is no display while power-on.	No input voltage is received from the power grid or the input voltage is too low.	Check the power supply.
		The switching power supply on the driver board of the AC drive is faulty.	Check the bus voltage or contact the agent or Inovance.
		The control board is disconnected from the driver board or operating panel.	Reconnect the 8-pin and 40-pin cables.
		The pre-charge resistor of the AC drive is damaged.	Contact the agent or Inovance.
		The control board or operating panel is faulty.	
The rectifier bridge is damaged.			
2	"CrAnE" is displayed while power-on.	The cable between the driver board and control board is not securely connected.	Reconnect the 8-pin and 28-pin cables.
		Components on the control board are damaged	Contact the agent or Inovance.
		The motor or motor cable is short circuited to the ground.	
		The Hall device is damaged.	
The mains voltage is too low.			
3	"Er123" is displayed while power-on.	The motor or motor cable is short circuited to the ground.	Use a megger to measure the insulation resistance of the motor and motor cable.
		The AC drive is damaged.	Contact the agent or Inovance.
4	The display is normal while power-on, but "CrAnE" is displayed in running state and the AC drive stops immediately.	The cooling fan is damaged or its blades are blocked.	Replace the cooling fan.
		Control terminals are short circuited.	Eliminate short circuits in the control circuit.

No.	Fault Description	Possible Cause	Solution
5	Er114 (IGBT overheat) is displayed frequently.	The carrier frequency is too high.	Reduce the carrier frequency (F0-15).
		The fan is damaged or the cooling air channel is blocked.	Replace the fan or clean the air channel.
		The thermistor or other components in the AC drive are damaged .	Contact the agent or Inovance.
6	The motor does not rotate when the AC drive is running.	The motor or motor cable does not work normally.	Check that the connection cable between the AC drive and motor is correct.
		Motor parameters are not set properly.	<ul style="list-style-type: none"> ◆ Restore factory settings and re-set the related parameters properly: ◆ Check that the encoder parameters and motor ratings, such as rated frequency and rated speed, are set properly. ◆ Check that b1.00 (Control mode) and bF.04 (Command source selection) are set correctly. ◆ Adjust F2.01 (Torque boost) in V/ F control under heavy load.
		The cable between the driver board and control board is not securely connected.	Re-connect the cable securely.
		The driver board is faulty.	Contact the agent or Inovance.
7	DI terminals are disabled.	Related parameters are set incorrectly.	Check and modify parameters in group b3.
		External signals are incorrect.	Re-connect external signal cables.
		Jumper across OP and +24 V becomes loose.	Connect the jumper across OP and +24 V securely.
		The control board is faulty.	Contact the agent or Inovance.
8	The motor speed does not rise in closed-loop vector control.	The encoder is faulty.	Replace the encoder and check cable connection.
		The encoder is incorrectly connected or in poor contact.	Replace the PG card.
		The PG card is faulty.	Contact the agent or Inovance.
		The driver board is faulty.	

No.	Fault Description	Possible Cause	Solution
9	The AC drive reports overcurrent and overvoltage errors frequently.	Motor parameters are not set properly.	Set motor parameters or perform motor auto-tuning again.
		The acceleration/deceleration time is improper.	Set a proper acceleration/ deceleration time.
		The load fluctuates.	Contact the agent or Inovance.
10	Er117 is displayed when the AC drive is being powered on or running.	The contact on the pre-charge contactor is not closed.	<ul style="list-style-type: none"> ◆ Check that the contactor cable is securely connected. ◆ Check whether the contactor is faulty. ◆ Check whether the 24 V power supply of the contactor is faulty. ◆ Contact the agent or Inovance.

7.7 Error Sub-codes

The CS710 series AC drive provides error sub-codes to facilitate fault analysis and location. The two digits after the decimal point in a parameter of group E* indicate the error sub-code.

The following table describes error sub-codes.

Error Code	Code Meaning	Error Sub-code	Sub-code Meaning
02# to 04#	Overcurrent	1	Overcurrent on IGBT hardware
		10	Overcurrent on built-in braking unit
05# to 07#	Overvoltage	1	Software overvoltage fault 1
		2	Software overvoltage fault 2
08#	Pre-charge resistor overheat or control power supply fault	1	The voltage fluctuates during power-on, and the power-on process repeats more than five times within a short time due to undervoltage.
09#	Undervoltage	1	The bus voltage of the running AC drive is lower than the value of F3.06.
10#	AC drive overload	1	The overload fault is detected based on the overload curve of the AC drive.
		2	The output pulse-by-pulse current limiting time reaches 5s.
11#	Motor overload	1	Overload fault detected based on the overload curve of the motor



Error Code	Code Meaning	Error Sub-code	Sub-code Meaning
12#	Input phase loss	1	Input phase loss 1 by hardware detection
		2	Input phase loss 2 by hardware detection
		3	Input phase loss 1 by software detection
		4	Input phase loss 2 by software detection
14#	Heatsink or IGBT overheat	1	The inverter temperature exceeds the over-temperature threshold.
15#	Built-in braking transistor overloaded	1	The instantaneous current of the braking transistor exceeds two times the rated braking current.
		2	The instantaneous current of the braking transistor exceeds the AC drive overvoltage threshold divided by the minimum resistance.
		3	Overload fault detected based on the overload curve of the built-in braking transistor.
16#	Built-in braking transistor short circuited	1	The current of the braking transistor exceeds the detection threshold during the power-on or stop process of the AC drive.
17#	Pre-charge resistor not closed	1	Hardware pre-charge resistor detection fault 1
		2	Hardware pre-charge resistor detection fault 2
18#	Zero drift too large or current sensor failed	1	Too large zero drift on phase U
		2	Too large zero drift on phase V
		3	Too large zero drift on phase W
19#	Motor auto-tuning failure	1	No-load current abnormal
20#	The encoder is faulty.	1	Hardware encoder wire breaking detection (supported by MD38PGMD only)
		2	Software encoder wire breaking detection
		9	Incorrect pulses per revolution of the encoder obtained during dynamic complete auto-tuning in closed-loop vector control mode
		10	Encoder wire breaking detected during dynamic complete auto-tuning in closed-loop vector control mode
23#	Short circuit to ground	1	Hardware overcurrent occurs during detection of short circuit to ground.
		2	Hardware overvoltage occurs during detection of short circuit to ground.
		3	Detection current exceeds the rated peak current of the AC drive during detection of short circuit to ground.

7 Troubleshooting

Error Code	Code Meaning	Error Sub-code	Sub-code Meaning
25#	Output phase loss	1	Phase U output loss
		2	Phase V output loss
		3	Phase W output loss
		4	High output voltage in closed-loop vector control mode
		5	Output phase loss during stator resistance auto-tuning
37#	Stall pending 1	1	See the description of bC.02.
38#	Stall pending 2	1	See the description of bC.03 and bC.04.
40#	Pulse-by-pulse current limiting fault	1	Continuous pulse-by-pulse current limiting on any phase output in a short time

8 Maintenance and Inspection

8.1 Routine Maintenance

 Danger	<ul style="list-style-type: none"> ◆ Do not connect or disconnect cables while the power is on. ◆ Before the inspection, cut off the power supply. As there is residual voltage in the DC capacitor in the AC drive, wait for several minutes until the power indicator is off. Before powering on the AC drive again, wait for an interval specified by the AC drive. ◆ Do not change cable connections, remove cables, remove optional extension cards or replace fans while the power is on. ◆ Connect the motor-side grounding terminal. Failure to comply may result in electric shock due to touching motor housing. ◆ Do not allow unqualified personnel to do the repair & maintenance work. ◆ Installation, wiring, commissioning, repair & maintenance, and component replacement must be performed only by qualified technicians.
 Warning	<ul style="list-style-type: none"> ◆ Do not run the AC drive with the front cover removed. ◆ Drawings in the user guide are sometimes shown without covers or protective guards to display the details. Remember to install the covers or protective guards as specified first, and then perform operations in accordance with instructions. ◆ Tighten all terminal screws based on specified tightening torque. ◆ Ensure that input voltage is within the permissible range. Incorrect input voltage of main circuit may result in abnormal running. ◆ Keep combustible materials far away from the AC drive or mount the AC drive on incombustible surfaces such as a metal wall.
 Caution	<ul style="list-style-type: none"> ◆ Replace the cooling fan following the correct procedure as specified in this chapter. Ensure correct air outlet direction of the fan. An incorrect air direction will diminish the cooling effects. ◆ Do not connect or disconnect the motor while the AC drive is running. Failure to comply may result in electric shock and damage to the AC drive. ◆ Use shielded cables for control circuit wiring. ◆ Meanwhile, ground the shield to the grounding terminal reliably. ◆ Do not modify the AC drive circuitry. Failure to comply will damage the AC drive. ◆ Make sure to connect the output terminals of the AC drive and the motor terminals correctly. ◆ If it is necessary to change the motor rotation direction, exchange any two of UVW cables of the AC drive. ◆ Do not operate the AC drive that has been damaged. This is to prevent further damage to external equipment.

■ Routine maintenance items:

Influence of ambient temperature, humidity, dust and vibration will cause aging of components in the AC drive, which may cause potential faults or reduce the product life. Therefore, it is necessary to carry out routine and periodic maintenance. More frequent inspection will be required if it is used in harsh environments, such as:

- ◆ High ambient temperature
- ◆ Frequent starting and stopping
- ◆ Fluctuations in the AC power supply or load
- ◆ Excessive vibrations or shock loading
- ◆ Dust, metal dust, salt, sulfuric acid, chlorine atmospheres
- ◆ Poor storage conditions

Check the following items daily to avoid deterioration in performance or product. Copy this checklist and sign the "checked" column after each inspection.

Inspection Item	Inspection Points	Solutions	Checked
Motor	Inspect whether abnormal oscillation or noise exists.	<ul style="list-style-type: none"> ◆ Check mechanical connections. ◆ Check power phases of the motor. ◆ Tighten all loose screws. 	
Fan	Inspect whether the cooling fan of the AC drive and the motor works abnormally.	<ul style="list-style-type: none"> ◆ Check running of the drive cooling fan. ◆ Check running of the motor cooling fan. ◆ Check whether the cooling fan is clogged or dirty. ◆ Check whether the ambient temperature is within the permissible range. 	
Installation environment	Inspect whether the cabinet and cable duct are abnormal.	<ul style="list-style-type: none"> ◆ Check for input and output cables with insulation damaged. ◆ Check whether vibration exists on the hanging bracket. ◆ Check whether copper ground bars and terminals become loose or get corroded. 	
Load	Inspect whether the AC drive output current exceeds the AC drive or motor rating for an extended period of time.	<ul style="list-style-type: none"> ◆ Check for settings of motor parameters. ◆ Check for excessive load. ◆ Check for mechanical vibration (< 0.6 g in normal condition). 	
Input voltage	Check main power supply and control voltage.	<ul style="list-style-type: none"> ◆ Adjust the input voltage to the permissible range. ◆ Check whether start of heavy load exists. 	

8.2 Periodic Inspection

8.2.1 Periodic Inspection Items

Always keep the AC drive clean. Clear away dust especially metal powder on the surface of the AC drive, to prevent dust from entering the AC drive. Clear oil dirt from the cooling fan of the AC drive.

 Danger	<ul style="list-style-type: none"> ◆ Do not perform inspection work while the power is on. ◆ Before the inspection, disconnect all power supply and wait for 10 minutes to avoid the risk caused by the residual voltage in the capacitors of the AC drive.
---	---

Inspection Item	Inspection Points	Inspection Points	Checked
General	Inspect for waste, dirt and dust on the surface of the AC drive.	<ul style="list-style-type: none"> ◆ Check whether the AC drive is powered off. ◆ Use a vacuum cleaner to suck up waste and dust to prevent direct touching. ◆ Wipe surface dirt gently with a soft cloth immersed in neutral detergent. 	
Cables	Inspect power cables and connections for discoloration. Inspect wiring insulation for aging or wear.	<ul style="list-style-type: none"> ◆ Replace the cracked cable. ◆ Replace damaged terminals. 	
Peripheral devices such as the relay and contactor	Inspect contactors and relays for excessive noise during operation. Inspect coils for signs of overheating such as melted or cracked insulation. Check whether the coil voltage is normal.	<ul style="list-style-type: none"> ◆ Replace abnormal peripheral devices. 	
Ventilation	Inspect whether ventilation and heatsink are clogged. Check whether the fan is damaged.	<ul style="list-style-type: none"> ◆ Clean ventilation. ◆ Replace the fan. 	
Control circuit	Inspect for control components in poor contact. Inspect for loose terminal screws. Inspect for control cables with cracked insulation.	<ul style="list-style-type: none"> ◆ Clear away foreign materials on the surface of control cables and terminals. ◆ Replace damaged or corroded control cables. 	

8.2.2 Main Circuit Insulation Test

Before measuring the insulating resistance with a megameter (500 V DC megameter recommended), disconnect the main circuit from the AC drive. Do not use the megameter insulation test on the main circuit. Do not perform a high voltage (> 500 V) test because it

has been completed before delivery.

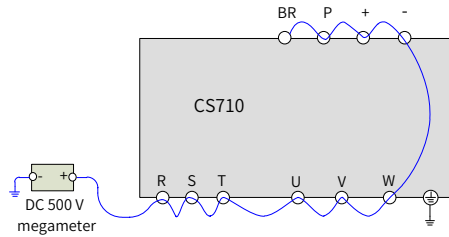

Figure 8-1 Insulation test on the main circuit

The measured insulation resistance must be greater than 5 MΩ.

Before the test, remove the VDR screw. Varistor (VDR) and safety capacitor (EMC)

8.3 Part Replacement

8.3.1 Service Life of Quick-wear Parts

The service life of fans and electrolytic DC bus capacitors depends on the operating environment and maintenance status. The following table lists the general service life of the parts.

Component	Service Life ^[Note]
Fan	≥ 5 years
Electrolytic DC bus capacitor	≥ 5 years



NOTE

- ◆ The preceding service life is obtained in the following conditions. You can determine when to replace these parts based on the actual operating time.
 Ambient temperature: 40°C
 Load rate: 80%
 Operating rate: 24 hours per day

8.3.2 Number of Fans on the AC Drive

Model	Number of Fans	Model	Number of Fans
Three-phase 380-480 V, 50/60 Hz			
CS710-4T0.4GB	/	CS710-4T45GB	1
CS710-4T0.7GB	/	CS710-4T55GB	1
CS710-4T1.1GB	/	CS710-4T75GB	2
CS710-4T1.5GB	1	CS710-4T90G	2
CS710-4T2.2GB	1	CS710-4T110G	2
CS710-4T3.0GB	1	CS710-4T132G	2
CS710-4T3.7GB	1	CS710-4T160G	2

Model	Number of Fans	Model	Number of Fans
CS710-4T5.5GB	1	CS710-4T200G	2
CS710-4T7.5GB	1	CS710-4T220G	2
CS710-4T11GB	2	CS710-4T250G	3
CS710-4T15GB	2	CS710-4T280G	3
CS710-4T18.5GB(-T)	1	CS710-4T315G	3
CS710-4T22GB(-T)	1	CS710-4T355G	3
CS710-4T30GB	1	CS710-4T400G	3
CS710-4T37GB	1	CS710-4T450G	3

8.3.3 Replacement of Fans

- 1) Possible causes of damage: bearing worn and blade aging
- 2) Replacement determination: whether there is crack on the blade; whether there is abnormal vibration noise upon startup; and whether the blade runs normally
- 3) Replacement method:
 - Depress the fan cover hook and put the cover out.
 - Keep the air flow direction upward.

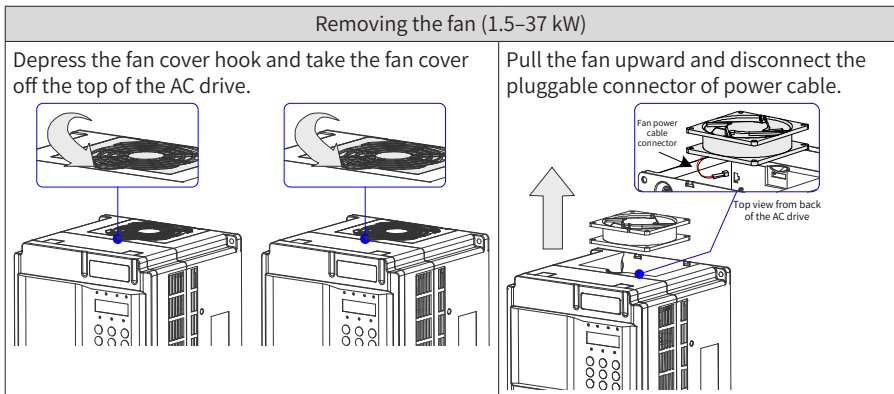

Installing the fan (1.5–37 kW)

- 1) Install the fan in reverse order of the removal procedure. Ensure the correct air flow direction.
- 2) Plug the fan's power cable to the socket, as shown in the following figure.

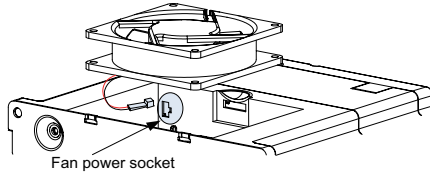

- 3) Install the fan into the AC drive and ensure that the four mounting pins are aligned.

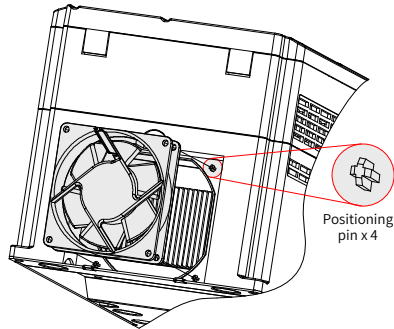

Installing the fan (1.5–37 kW)

- 4) Insert the two guide pins into the square holes and then press in the hook.

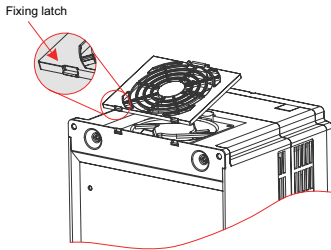

Keep the airflow of the fan upward.

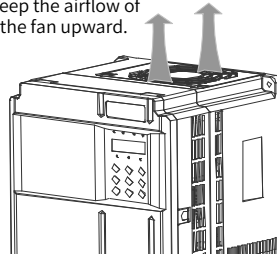

Removing the fan (45–160 kW)

Unplug the fan's power cable from the socket (top view).

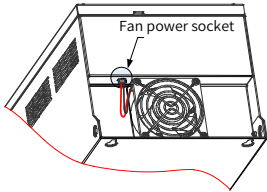

Remove the four screws from the fan cover.

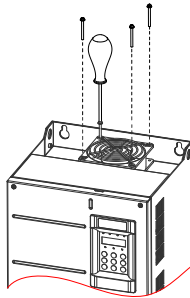

Remove the fan cover and fan from the AC drive.

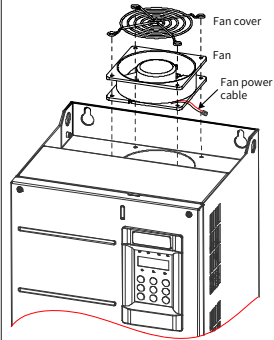

Installing the fan (45–160 kW)

- 1) Install the fan in reverse order of the removal procedure. Ensure the correct air flow direction.
- 2) Install the fan cover and fan into the AC drive and ensure that the four mounting pins are aligned, as shown by dotted lines in Figure ③ .
- 3) Keep the air flow direction upward.

Keep the airflow of the fan upward.

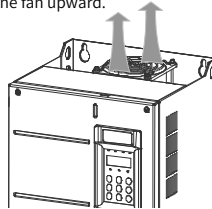

Removing the fan (200–450 kW)

- 1) Remove the six screws and pull the front cover in the direction of the arrowhead.

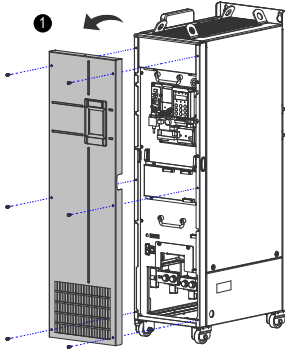

- 2) Unplug the fan's power cable connector from the socket. Each fan has a power cable connector.

- 3) Remove the three screws from the fan box and draw the fan box out in the direction of arrowhead.

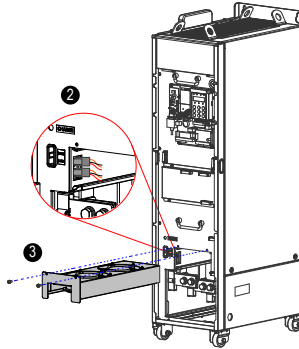

- 4) Remove the four screws from each fan cover and remove the fan.

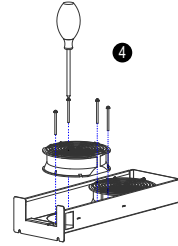

Installing the fan (200–450 kW)

- 1) Install the fan in reverse order of the removal procedure. Ensure the correct air flow direction.
- 2) Align the fan box with the rails and push it into the AC drive.
- 3) Connect the fan power cable connector before fixing the fan cover. After replacing the fan, check that the air flow direction is upright.

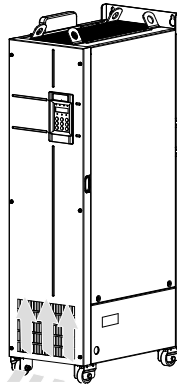

8.3.4 DC Bus Electrolytic Capacitors

- 1) Possible causes of damage: input power supply in poor quality; high ambient temperature; frequent load jumping; and electrolytic aging
- 2) Replacement determination: Whether there is liquid leakage; whether the sage valve has projected; measure the static capacitance; and measure the insulation resistance.
- 3) Replacement of electrolytic capacitor: As the replacement affects the internal components of the AC drive, contact the agent or Inovance for the replacement.

8.3.5 Replacement of the Surge Protection Board

An independent surge protection board is equipped for the AC drive of 45 kW and above. For the AC drive of 37 kW and below, the surge protection board is integrated with the driver board.

- 1) Installation position of the surge protection board: The surge protection board must be connected to the R/S/T terminals. Generally, the surge protection board is installed near the R/S/T input terminals where some blue or yellow VDRs are installed. With an input phase loss detection circuit equipped, the surge protection board is connected to the driver board using a 2-pin terminal, as shown in the following figure.

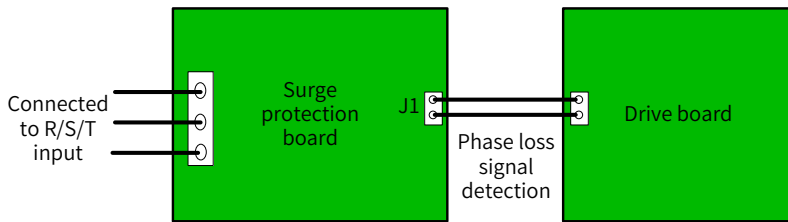

- 2) Replacement of the surge protection board: If the surge protection board is damaged or corroded severely, replace the board.

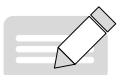

NOTE

- ◆ The input phase loss detection circuit on the surge protection board is used for phase loss signal detection of the driver board and cannot be removed.

8.4 Storage

For storage of the AC drive, pay attention to the following points:

- 1) Pack the AC drive with the original packing box provided by Inovance.
- 2) Do not expose the AC drive to moisture, high temperature, or outdoor direct sunlight for a long time.
- 3) The electrolytic capacitor will deteriorate after being stored for a long time. Therefore, the AC drive must be switched on once every 6 months and keep it running for at least 5 hours each time. Increase the input voltage to the rated value gradually by using a voltage regulator.

9 Technical Data and Model Selection

9.1 Technical Data

Table 9-1 CS710 AC drive models and technical data

Item		Specifications									
Model: CS710-4TxxG(B) ^[1]		0.4	0.7	1.1	1.5	2.2	3	3.7	5.5	7.5	11
Motor Capacity (kW)		0.4	0.75	1.1	1.5	2.2	3	3.7	5.5	7.5	11
Input	Rated Input Current (A)	1.8	2.4	3.7	4.6	6.3	9	11.4	16.7	21.9	32.2
Output	Rated Output Current (A)	1.5	2.1	3.1	3.8	5.1	7.2	9	13	17	25
	Max. Output Voltage	Three-phase 380-480 V (proportional to input voltage)									
	Max. Output Frequency	150 Hz (configurable)									
	Carrier frequency	1.0-6.0 kHz (vector control) 1.0-12 kHz (V/F control)									
	Overload capacity	Running at 150% of rated current for 60s									
Power Supply	Rated Voltage and Frequency	Three-phase 380-480 VAC, 50/60 Hz									
	Allowed Voltage Deviation	-15% to +10%, allowed voltage range: 323–528 VAC									
	Allowed Frequency Deviation	±5%									
	Power Capacity (kVA)	2	2.8	4.1	5	6.7	9.5	12	17.5	22.8	33.4
Thermal Design Power (kW)		0.039	0.046	0.057	0.068	0.081	0.109	0.138	0.201	0.24	0.355
Air Volume (CFM)		-	-	-	9	9	9	20	24	30	40

Item		Specifications									
Model: CS710-4TxxG(B) ^[1]		15	18.5	22	30	37	45	55	75	90	110
Motor Capacity (kW)		15	18.5	22	30	37	45	55	75	90	110
Input	Rated Input Current (A)	41.3	49.5	59	57	69	89	106	139	164	196
Output	Rated Output Current (A)	32	37	45	60	75	91	112	150	176	210
	Max. Output Voltage	Three-phase 380-480 V (proportional to input voltage)									
	Max. Output Frequency	150 Hz (configurable)									
	Carrier frequency	1.0-6.0 kHz (vector control), 1.0-12 kHz (V/F control)									
	Overload capacity	Running at 150% of rated current for 60s									
Power Supply	Rated Voltage and Frequency	Three-phase 380-480 VAC, 50/60 Hz									
	Allowed Voltage Deviation	-15% to +10%, allowed voltage range: 323–528 VAC									
	Allowed Frequency Deviation	±5%									
	Power Capacity (kVA)	42.8	45	54	52	63	81	97	127	150	179
Thermal Design Power (kW)		0.454	0.478	0.551	0.694	0.815	1.01	1.21	1.57	1.81	2.14
Air Volume (CFM)		42	51.9	57.4	118.5	118.5	122.2	122.2	218.6	287.2	342.2

Item		Specifications									
Model: CS710-4TxxG(B) ^[1]		132	160	200	220	250	280	315	355	400	450
Motor Capacity (kW)		132	160	200	220	250	280	315	355	400	450
Input	Rated Input Current (A)	240	287	365	410	441	495	565	617	687	782
Output	Rated Output Current (A)	253	304	377	426	465	520	585	650	725	820
	Max. Output Voltage	Three-phase 380-480 V (proportional to input voltage)									
	Max. Output Frequency	150 Hz (configurable)									
	Carrier frequency	1.0-6.0 kHz (vector control), 1.0-12 kHz (V/F control)									
	Overload capacity	Running at 150% of rated current for 60s									
Power Supply	Rated Voltage and Frequency	Three-phase 380-480 VAC, 50/60 Hz									
	Allowed Voltage Deviation	-15% to +10%, allowed voltage range: 323–528 VAC									
	Allowed Frequency Deviation	±5%									
	Power Capacity (kVA)	220	263	334	375	404	453	517	565	629	716
Thermal Design Power (kW)		2.85	3.56	4.15	4.55	5.06	5.33	5.69	6.31	6.91	7.54
Air Volume (CFM)		547	627	638.4	722.5	789.4	882	645	860	860	860

[1]The rated power of the AC drive is measured at 440 VAC input voltage.

Table 9-2 Technical specifications of the CS710 series AC drives

Item		Description
Standard functions	Input frequency resolution	Digital setting: 0.01 Hz Analog setting: Maximum frequency x 0.025%
	Control mode	Sensorless vector control (SVC) Flux vector control (FVC) V/F control
	Startup torque	0.25 Hz/150% (SVC); 0 Hz/180% (FVC)
	Speed range	1:200 (SVC) 1:1000 (FVC)
	Speed stability accuracy	±0.5% (SVC) ±0.02% (FVC)
	Torque control accuracy	±3% (FVC); ±5% for 10 Hz above (SVC)
	Torque boost	Automatic torque boost; customized torque boost: 0.1% to 30.0 %
	DC injection braking	DC injection braking frequency: Minimum frequency to rated frequency DC injection braking current: 0.0%-120.0% of rated current
	Ramp mode	Straight-line or S-curve ramp
	Automatic voltage regulation (AVR)	This function maintains constant output voltage when the mains voltage changes.
	Oversvoltage and overcurrent stall control	The system limits the output current and voltage automatically during operation to prevent frequent trips caused by oversvoltage and overcurrent.
	Rapid current limiting	This function minimizes the number of overcurrent incidents, ensuring normal operation of the AC drive.
	Torque limit and control	The system limits the torque automatically to prevent frequent trips caused by overcurrent during operation. Torque control is applied in vector control mode.

Item	Description
Customized functions	Crane process card The AC drive can use a crane process card to implement complex crane processing control for components such as the built-in anti-swing device and grab.
	Overload protection The AC drive automatically detects overload conditions. When overload occurs, the AC drive allows only dropping action and prohibit hoisting action.
	Multi-motor switchover The AC drive saves three sets of parameter settings to allow switchover between three motors.
	Support for multiple field buses The AC drive supports four types of field buses: Modbus, PROFIBUS-DP, CANopen, and PROFINET.
	Motor overheat protection When the AC drive is equipped with optional extension I/O card 1, its AI3 terminal can receive input signals from the motor's temperature sensor (PT100 or PT1000).
	Support for multiple encoder types The AC drive supports a range of encoder types: differential encoder, open-collector encoder, and resolver.
	Power dip ride-through When the bus voltage is too low, the AC drive can keep the voltage at a normal level through load feedback energy.
	Brake time sequence control The AC drive has crane-specific brake time sequence control capability.
	Light-load high-speed The maximum output frequency can be automatically calculated based on the output torque of the AC drive.
	Special curve Three-segment acceleration/deceleration curves are supported.
	Load overspeed judgment The AC drive can report alarms on frequency direction errors and frequency following errors based on frequency feedback from the encoder.
	Deceleration/ Stop switch It implements the simple positioning function.
	Alarms on various faults You can set the fault report type and handling method.
	Static motor auto-tuning All motor parameters can be obtained through static auto-tuning.
	Advanced software tool The AC drive software allows you to configure operating parameters, and provides a virtual oscilloscope display to show system status.

Item		Description
Operation	Command source	AC drive control commands can be delivered through the operating panel, control terminals, or serial communication (RS-485/CANopen/DP).
	Frequency reference	Frequency reference can be set through the following channels: multi-frequency, analog voltage, analog current, and serial communication.
	Input terminals	Standard: Five DI terminals Two AI terminals, one of which supports only 0 to 10 V voltage input and the other supports both 0 to 10 V voltage input and 4 to 20 mA current input. Expanded capacity: CS700IO1 extension card configured in models with 11 kW or lower power ratings, adding two DI terminals CS700RC2 extension card configured in models with 15 kW or higher power ratings, adding two DI terminals
	Output terminals	Standard: Two DO terminals One relay output terminal One analog output (AO) terminal that supports 0 to 10 V voltage output and 0 to 20 mA current output Expanded capacity: CS700IO1 extension card configured in models with 11 kW or lower power ratings, adding one relay output terminal CS700RC2 extension card configured in models with 15 kW or higher power ratings, adding two relay output terminals
Display and operating panel	LED display	It shows parameter values.
	Parameter cloning	The parameter cloning panel allows parameters to be replicated quickly.

Item		Description
Protection functions	Phase loss protection	The AC drive provides input phase loss protection and output phase loss protection.
	Instantaneous overcurrent protection	The AC drive stops when the running current exceeds 250% of rated output current.
	Oversvoltage protection	The AC drive stops when the DC bus voltage exceeds 820 V.
	Undersvoltage protection	The AC drive stops when the DC bus voltage falls below 350 V.
	Overheat protection	Protection is triggered when the inverter bridge overheats.
	Overload protection ^[1]	The AC drive stops after running at 150% of rated current for 60 seconds.
	Braking protection	The AC drive provides braking unit overload protection and braking resistor short-circuit protection.
	Short-circuit protection	The AC drive provides input inter-phase short-circuit protection and output phase-to-ground short-circuit protection.
Environment	Installation site	Install the AC drive in an indoor environment free from direct sunlight, dust, corrosive or combustible gases, oil smoke, vapor, ingress from water or any other liquid, and salt.
	Altitude	The power rating of the AC drive does not change at an altitude below 1000 m. If the altitude exceeds 1000 m, the power rating decreases by 1% every time the altitude increases by 100 m. The maximum altitude allowed is 3000 m.
	Ambient temperature:	-10°C to +40°C If the ambient temperature exceeds 40°C, the power rating decreases by 1.5% every time the temperature increases by 1°C. The highest ambient temperature allowed is 50°C.
	Humidity	Less than 95% RH, non-condensing
	Vibration	Less than 5.9 m/s ² (0.6 g)
	Storage temperature	-20°C to +60°C

[1] The rated power of the AC drive is measured at 440 V AC input voltage.

9.2 Installation Dimensions

9.2.1 Dimensions of 0.4–160 kW AC Drive Models

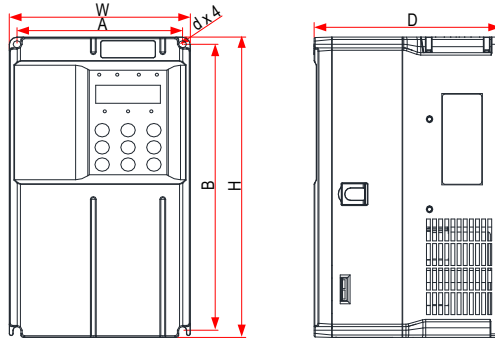

Figure 9-1 External dimensions and mounting dimensions of 0.4–15 kW AC drive models

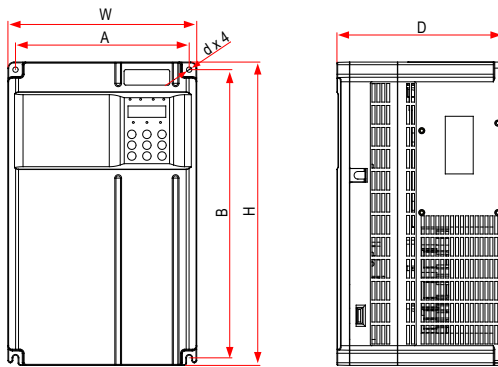

Figure 9-2 External dimensions and mounting dimensions of 18.5–37 kW AC drive models

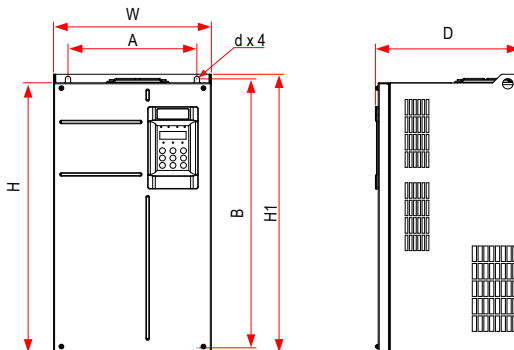

Figure 9-3 External dimensions and mounting dimensions of 45–160 kW AC drive models

Table 9-3 External dimensions and mounting hole spacing of 45–160 kW AC drive models

AC Drive Model	Hole Spacing (mm)		Dimensions (mm)				Hole Diameter (mm)	Weight (kg)
	A	B	H	H1	W	D		
CS710-4T0.4GB	119	189	200	-	130	152	Ø5	1.6
CS710-4T0.7GB								
CS710-4T1.1GB								
CS710-4T1.5GB								
CS710-4T2.2GB								
CS710-4T3.0GB								
CS710-4T3.7GB	119	189	200	-	130	162	Ø5	2.0
CS710-4T5.5GB								
CS710-4T7.5GB	128	238	250	-	140	170	Ø6	3.3
CS710-4T11GB								
CS710-4T15GB	166	266	280	-	180	170	Ø6	4.3
CS710-4T18.5GB	195	335	350	/	210	192	Ø6	9.1
CS710-4T22GB								
CS710-4T30GB	230	380	400	/	250	220	Ø7	17.5
CS710-4T37GB								
CS710-4T45GB	245	523	525	542	300	275	Ø10	35
CS710-4T55GB								
CS710-4T75GB	270	560	554	580	338	315	Ø10	51.5
CS710-4T90G								
CS710-4T110G								
CS710-4T132G	320	890	874	915	400	320	φ10	85
CS710-4T160G								

9.2.2 Dimensions of 0.4–160 kW AC Drive Models with Mounting Bracket

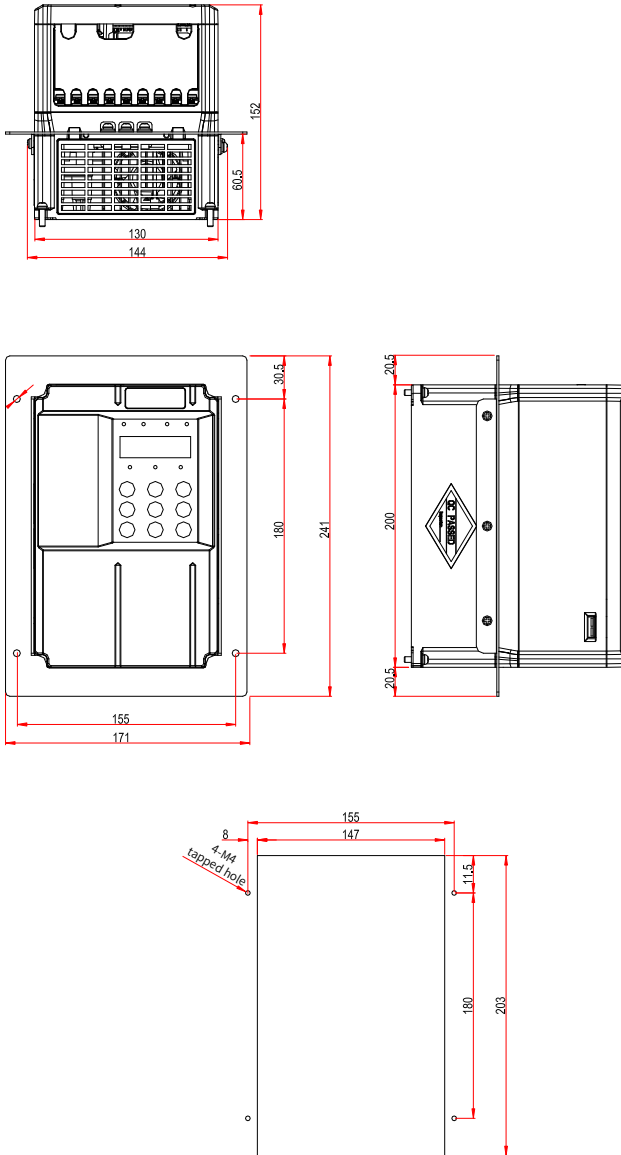

Figure 9-4 Mounting bracket dimensions and hole spacing for 0.4–3.0 kW AC drive models

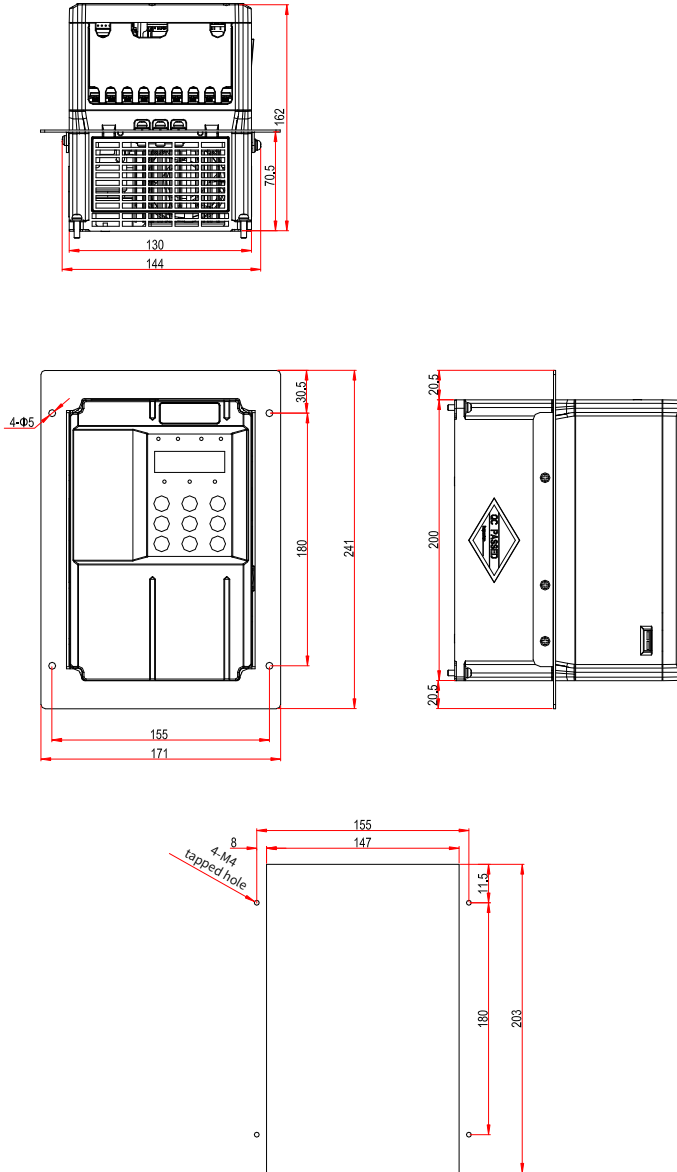

Figure 9-5 Mounting bracket dimensions and hole spacing for 3.7–5.5 kW AC drive models

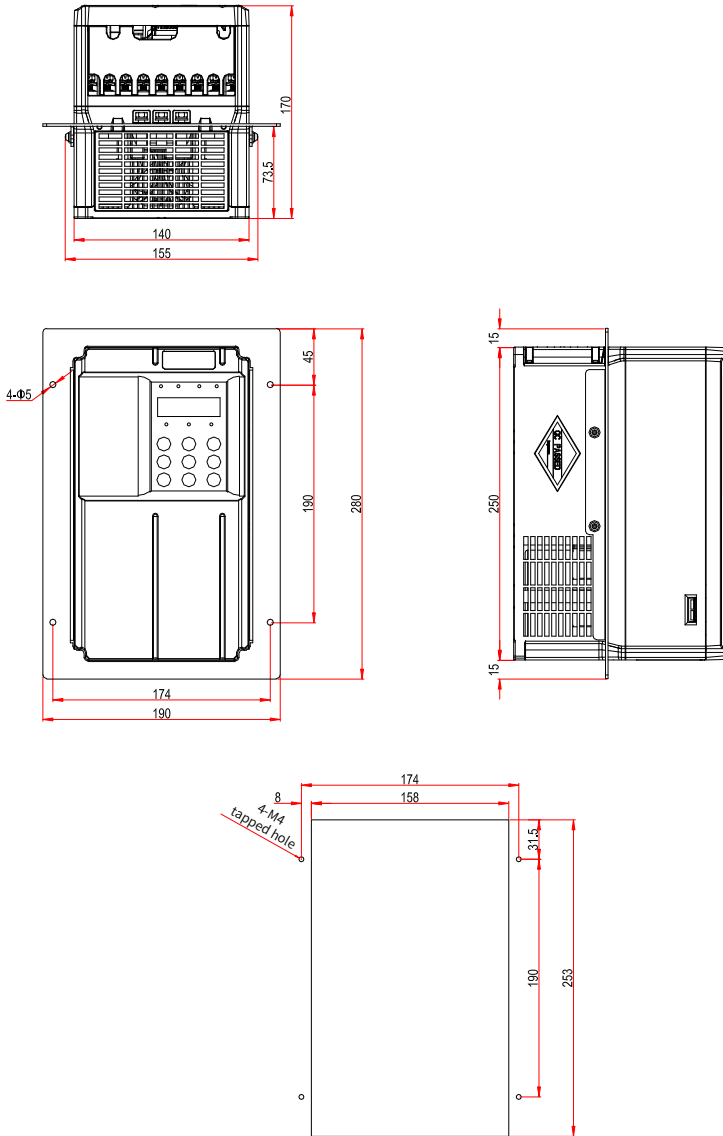

Figure 9-6 Mounting bracket dimensions and hole spacing for 7.5–11 kW AC drive models

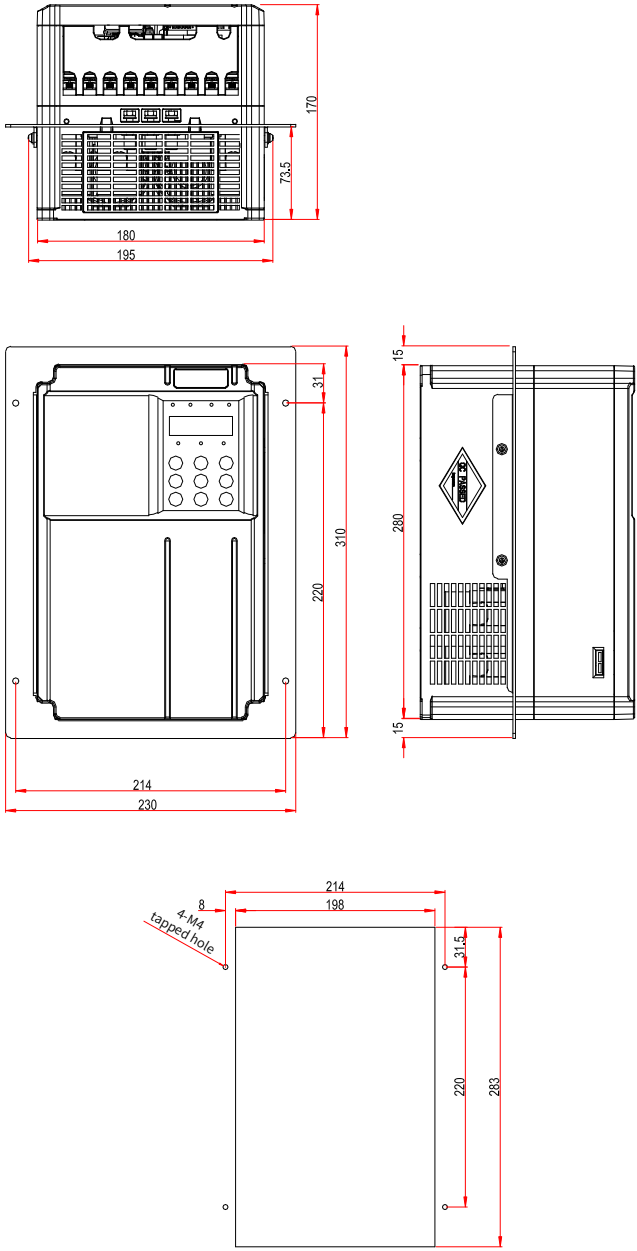

Figure 9-7 Mounting bracket dimensions and hole spacing for 15 kW AC drive models

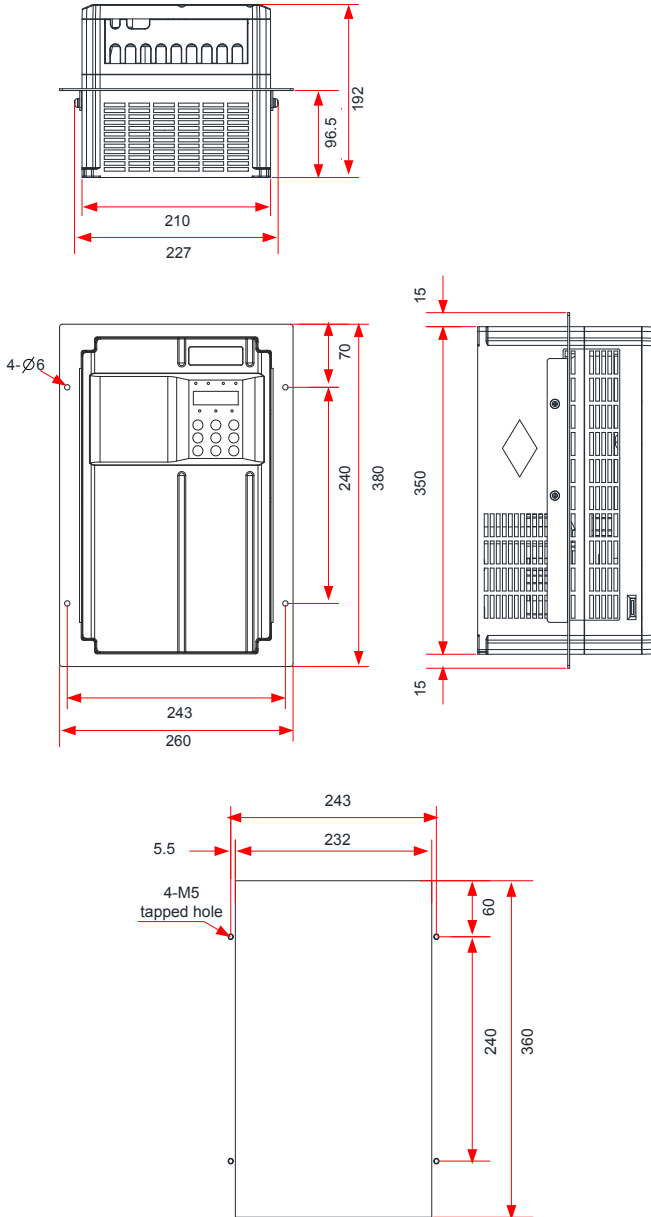

Figure 9-8 Mounting bracket dimensions and hole spacing for 18.5–22 kW AC drive models

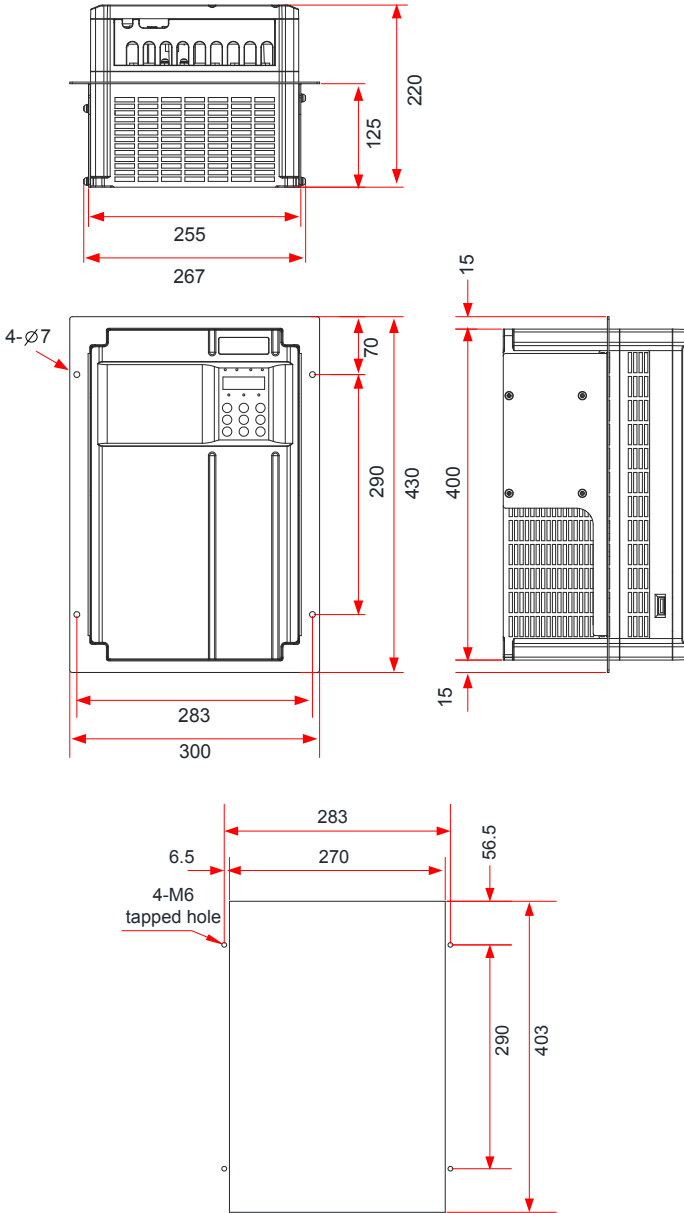

Figure 9-9 Mounting bracket dimensions and hole spacing for 30–37 kW AC drive models

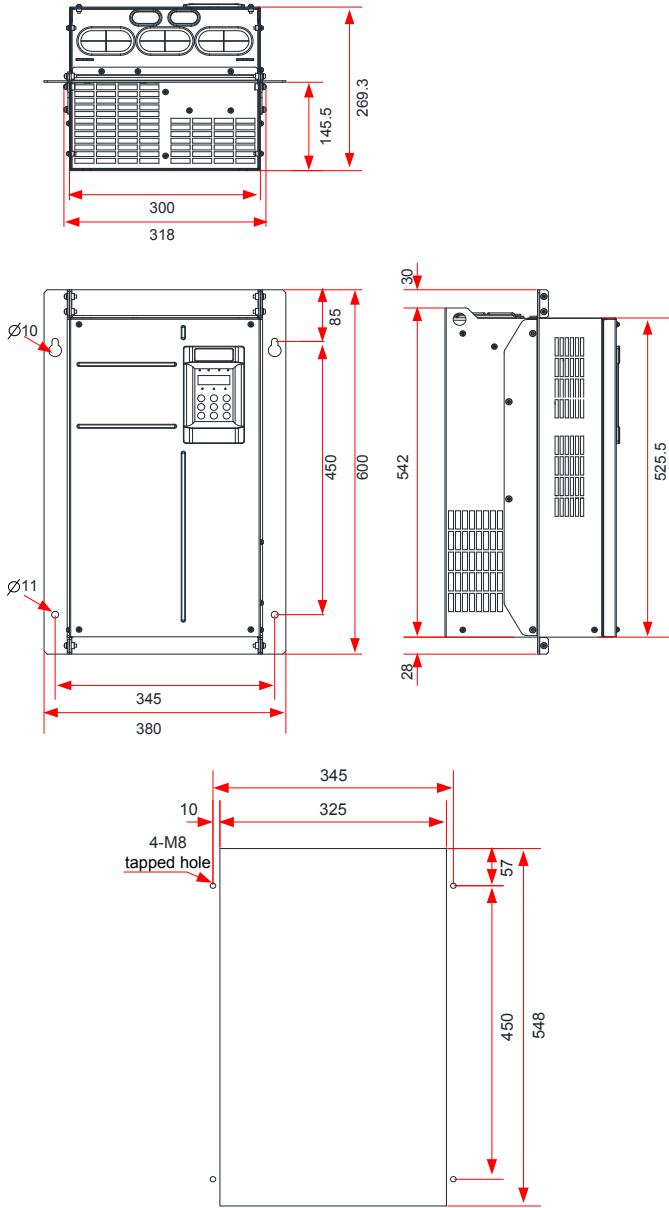

Figure 9-10 Mounting bracket dimensions and hole spacing for 45–55 kW AC drive models

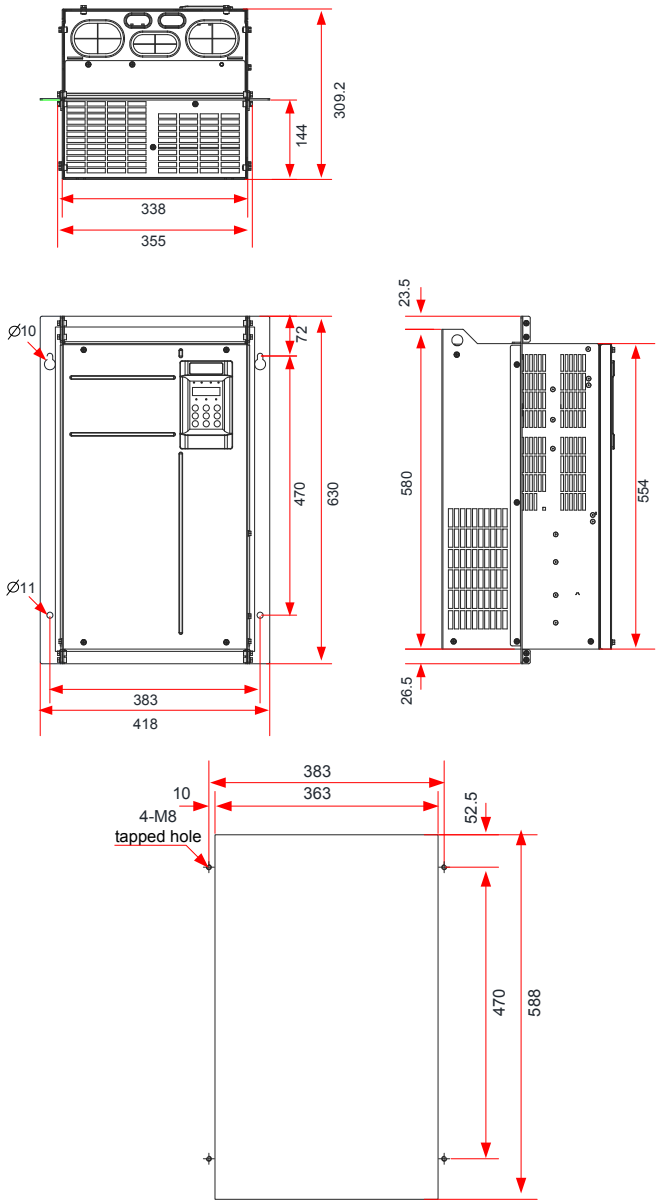

Figure 9-11 Mounting bracket dimensions and hole spacing for 75–110 kW AC drive models

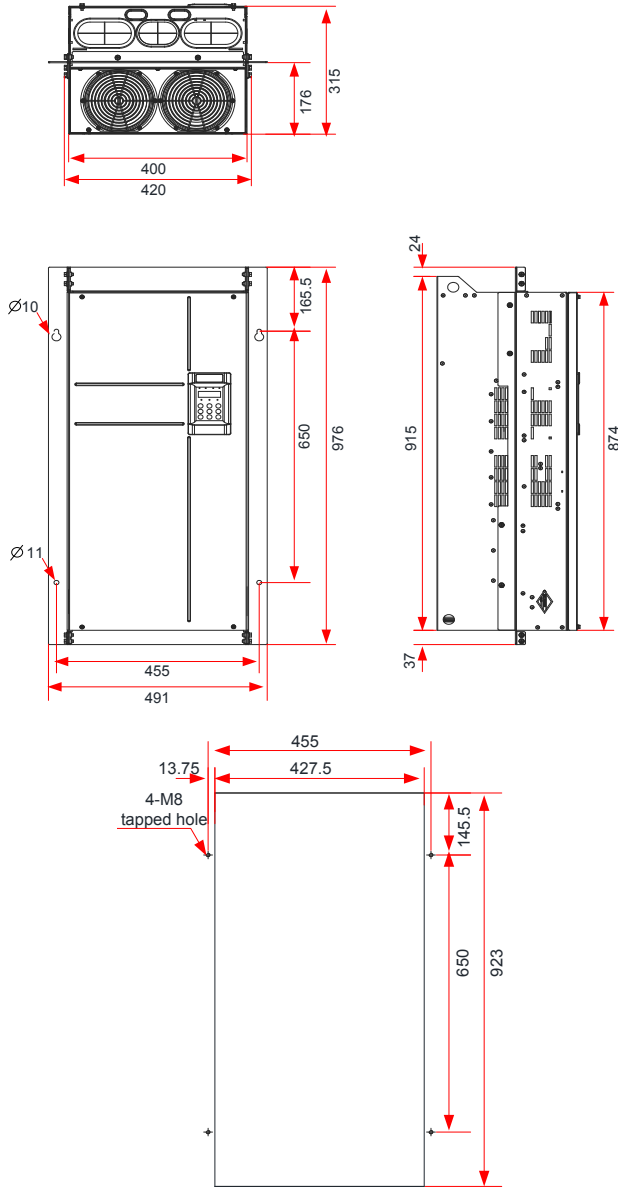

Figure 9-12 Mounting bracket dimensions and hole spacing for 132–160 kW AC drive models

9.2.3 Dimensions of 200–450 kW AC Drive Models

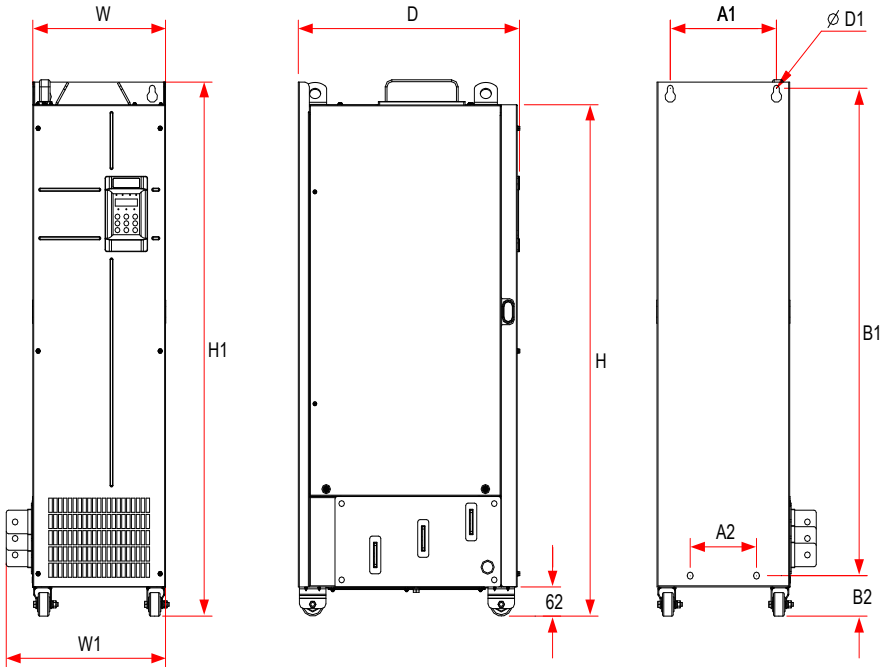

Figure 9-13 External dimensions and mounting dimensions of 200–450 kW AC drive models (without the reactor base)

Table 9-4 Mounting hole spacing for 200-450 kW AC drive models (without the reactor base)

AC Drive Model	Hole Spacing (mm)				Dimensions (mm)					Hole Diameter (mm)	Weight (kg)
	A1	A2	B1	B2	H	H1	W	W1	D		
CS710-4T200G	240	150	1035	86	1086	1134	300	360	500	Ø13	110
CS710-4T220G											
CS710-4T250G	225	185	1175	97	1248	1284	330	390	545	Ø13	155
CS710-4T280G											
CS710-4T315G	240	200	1280	101	1355	1405	340	400	545	Ø16	185
CS710-4T355G											
CS710-4T400G											
CS710-4T450G											

9.2.4 Dimensions of 200–450 kW AC Drive Models with Reactor Base

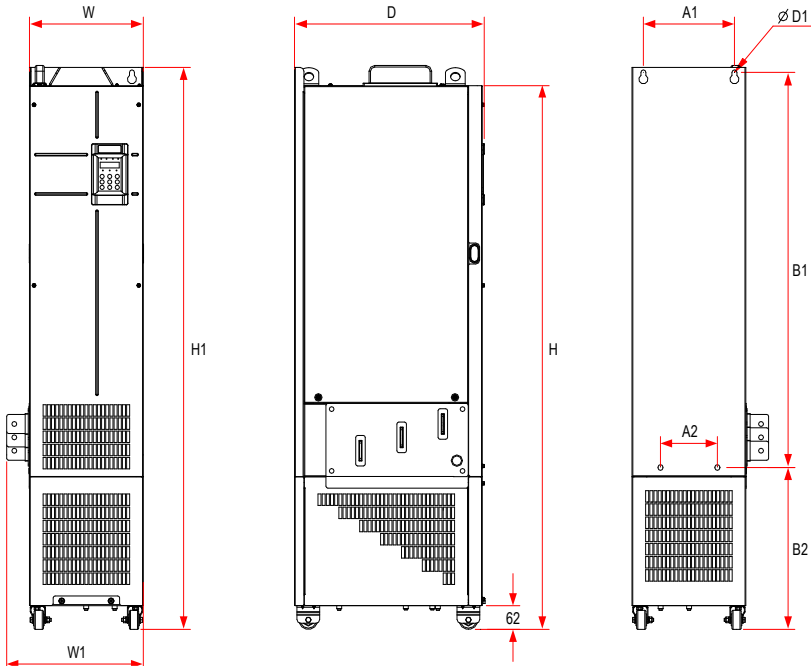

Figure 9-14 External dimensions and mounting dimensions of 200–450 kW AC drive models (with the reactor base)

Table 9-5 Mounting hole spacing for 200–450 kW AC drive models (with the reactor base)

AC Drive Model	Hole Spacing (mm)				Dimensions (mm)					Hole Diameter (mm)	Weight (kg)
	A1	A2	B1	B2	H	H1	W	W1	D	D1	
CS710-4T200G-L	240	150	1035	424	1424	1472	300	360	500	Ø13	160
CS710-4T220G-L											
CS710-4T250G-L	225	185	1175	435	1586	1622	330	390	545	Ø13	215
CS710-4T280G-L											

AC Drive Model	Hole Spacing (mm)				Dimensions (mm)					Hole Diameter (mm)	Weight (kg)
	A1	A2	B1	B2	H	H1	W	W1	D		
CS710-4T315G-L	240	200	1280	432	1683	1733	340	400	545	Ø16	245
CS710-4T355G-L											
CS710-4T400G-L											
CS710-4T450G-L											

9.2.5 Mounting Bracket Dimensions

■ Dimensions of the mounting bracket for 200–220 kW models

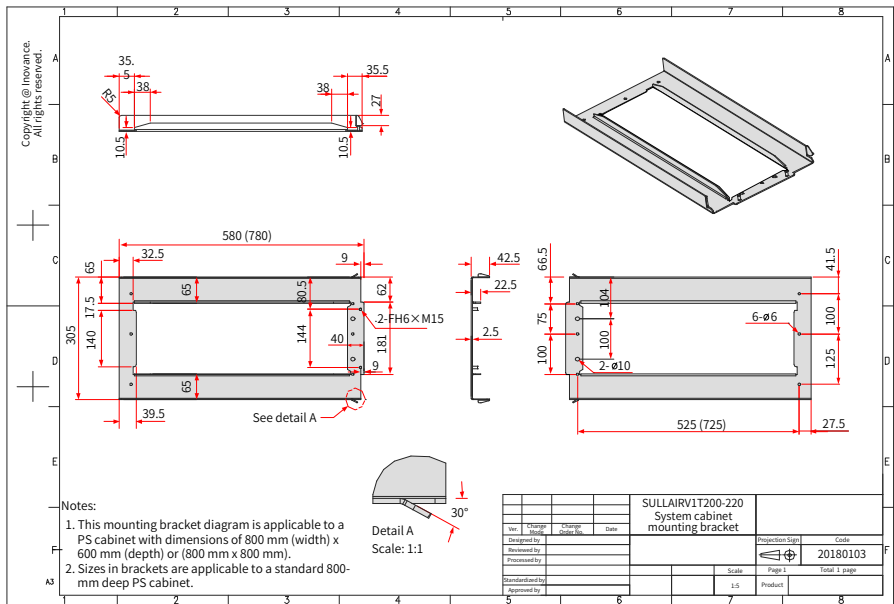

Figure 9-15 Dimensions of the mounting bracket for 200-220 kW models (standard configuration)

■ Dimensions of the mounting bracket for 250–280 kW models

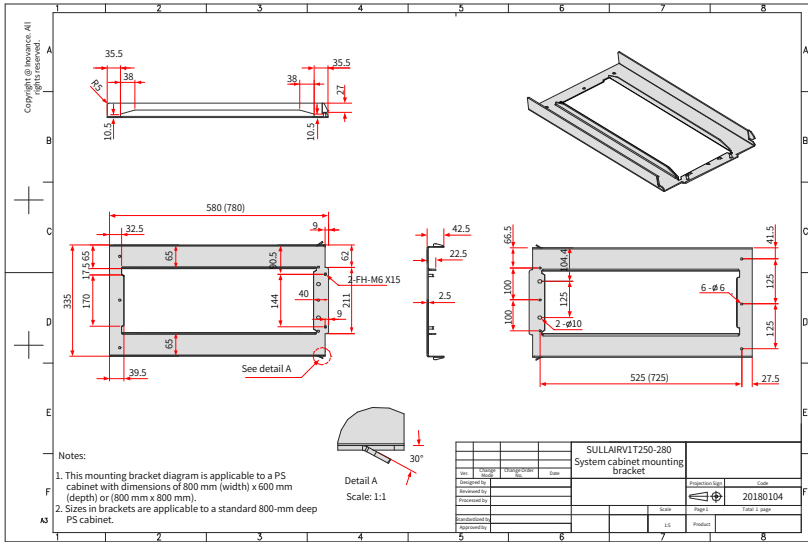

Figure 9-16 Dimensions of the mounting bracket for 250–280 kW models (standard configuration)

■ Dimensions of the Mounting Bracket for 315-450 kW Models

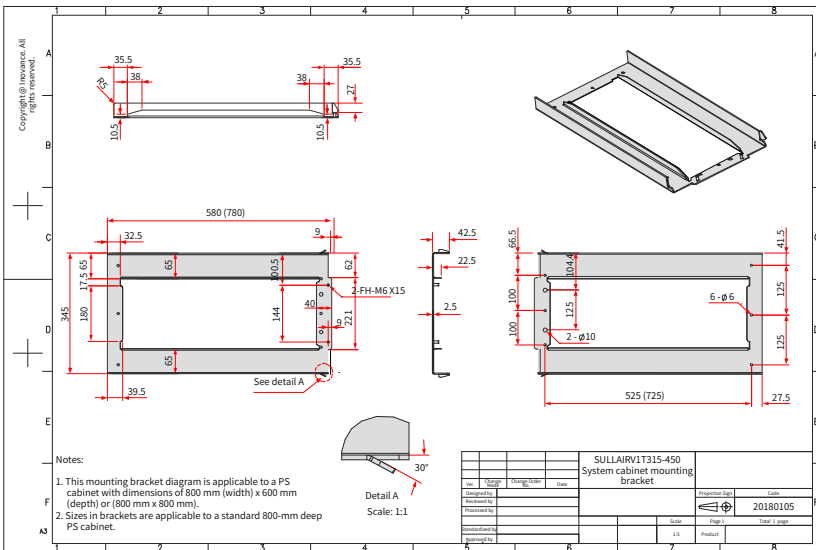

Figure 9-17 Dimensions of the mounting bracket for 315–450 kW models (standard configuration)

9.3 Options

Optional peripherals parts include braking units, function extension cards, and external operating panel, as listed in the following table. For use of a specific part, see its user guide. To purchase the following parts, specify the parts in the order.

Table 9-6 List of optional parts

Name	Model	Function	Remarks
Built-in braking unit	Marked "B".	0.4–75 kW, optional braking unit	-
External braking unit	MDBUN	Required for models of 90 kW and higher ratings	Parallel connection of multiple braking units supported by models of 90 kW and higher ratings
I/O extension card 1	MD38IO1	Adds five DI terminals and one AI terminal. Supports PT100 and PT1000 temperature sensors, and provides one relay output terminal, one DO terminal, one AO terminal, and Modbus/CANlink ports.	Available to models of 15 kW and higher ratings
I/O extension card 2	MD38IO2	Adds three DI terminals.	Available to all models
I/O extension card 3	CS700RC2	Adds two relay output terminals, three DI terminals, and one RS-485 port.	Standard configuration for models of 15 kW and higher ratings
I/O extension card 4	CS700IO1	Adds one relay output terminals, two DI terminals, and one RS-485 port.	Standard configuration for models of 11 kW and lower ratings
RS-485 communication card	MD38TX1	Isolated card for Modbus communication	Available to all models
CANopen communication card	MD38CAN2	Used for CANopen communication	Available to all models
PROFIBUS-DP communication card	MD38DP2	PROFIBUS-DP communication card	Available to models of 15 kW and higher ratings
PROFINET communication card	MD500-PN1	Used for PROFINET communication	Available to all models

Name	Model	Function	Remarks
Multi-functional encoder card	MD38PGMD	Compatible with differential input, open-collector input, and push-pull input Supports differential output and open-collector output Compatible with A/B phase input interfaces of commonly used encoders and host controllers	Available to all models
Resolver interface card	MD38PG4	Applicable to a resolver that has an excitation frequency of 10 kHz, DB9 interface	Available to all models
External LED operating panel	MD32NKE1	External LED display and operating panel	Available to the MD series RJ45 interface
External LCD operating panel	MDKE9	Display and adjust parameters, support upload and download of parameter list, and language selection (Chinese or English)	RJ45 interface
Extension cable	MDCAB	Standard 8-core cable that can be connected to MD32NKE1	Standard length: 3 m
Through-hole mounting bracket	MD500-AZJ-A1T*	Used to mount the AC drive to the middle of the cabinet	Each model has its own bracket. For details, see Table 3-1 "List of mounting bracket models for through-hole mounting" in Chapter 3.
Shield cable support bracket	MD500-AZJ-A2T*	Used for secondary fixing of power cables and stable 360° grounding of the shield	Each model has its own bracket.

9.4 Selection of Peripheral Electrical Devices

9.4.1 List of Peripheral Electrical Devices

Table 9-7 Recommended peripheral electrical devices for CS710 AC drives

CS710 Series Model	Input IEC Cable (mm ²) ⁽¹⁾	IEC Ground Cable (mm ²)	Output IEC Cable (mm ²)	Terminal Width (mm)	Screw	Recommended Fuse Bussmann UL Certification		Contactor	Circuit Breaker
						Rated Current (A)	Model		
Three-phase 380-480 V, 50/60 Hz									
CS710-4T0.4GB	3 x 0.75	0.75	3 x 0.75	10.2	M4	5	FWP-5B	9	3
CS710-4T0.7GB	3 x 0.75	0.75	3 x 0.75	10.2	M4	5	FWP-5B	9	4
CS710-4T1.1GB	3 x 0.75	0.75	3 x 0.75	10.2	M4	10	FWP-10B	9	6
CS710-4T1.5GB	3 x 0.75	0.75	3 x 0.75	10.2	M4	10	FWP-10B	9	6
CS710-4T2.2GB	3 x 0.75	0.75	3 x 0.75	10.2	M4	10	FWP-10B	9	10
CS710-4T3.0GB	3 x 1	1	3 x 1	10.2	M4	15	FWP-15B	12	13
CS710-4T3.7GB	3 x 1.5	1.5	3 x 1.5	10.2	M4	20	FWP-20B	16	16
CS710-4T5.5GB	3 x 2.5	2.5	3 x 2.5	10.2	M4	≥ 30	FWP-30B	26	25
CS710-4T7.5GB	3 x 4	4	3 x 4	13.0	M5	40	FWP-40B	26	32
CS710-4T11GB	3 x 6	6	3 x 6	13.0	M5	60	FWP-60B	38	50
CS710-4T15GB	3 x 10	10	3 x 10	14.3	M5	70	FWH-70B	50	63
CS710-4T18.5GB (-T)	3 x 10	10	3 x 10	15.0	M6	80	FWH-80B	65	63
CS710-4T22GB (-T)	3 x 16	16	3 x 16	15.0	M6	100	FWH-100B	65	80
CS710-4T30GB	3 x 16	16	3 x 16	18.0	M6	100	FWH-100B	65	80
CS710-4T37GB	3 x 25	16	3 x 25	18.0	M6	125	FWH-125B	80	100
CS710-4T45GB	3 x 35	16	3 x 35	26.8	M8	150	FWH-150B	95	160
CS710-4T55GB	3 x 50	25	3 x 50	26.8	M8	200	FWH-200B	115	160
CS710-4T75GB	3 x 70	35	3 x 70	30.6	M12	250	FWH-250A	150	250
CS710-4T90G	3 x 95	50	3 x 95	30.6	M12	275	FWH-275A	170	250
CS710-4T110G	3 x 120	70	3 x 120	30.6	M12	325	FWH-325A	205	250
CS710-4T132G	3 x 150	95	3 x 150	*	M12	400	FWH-400A	245	400
CS710-4T160G	3 x 185	95	3 x 185	*	M16	500	FWH-500A	300	400
CS710-4T200G(-L)	2 x (3 x 95)	95	2 x (3 x 95)	*	M12	600	FWH-600A	410	500
CS710-4T220G(-L)	2 x (3 x 120)	120	2 x (3 x 120)	*	M12	700	FWH-700A	410	630

CS710 Series Model	Input IEC Cable (mm ²) ^[1]	IEC Ground Cable (mm ²)	Output IEC Cable (mm ²)	Terminal Width (mm)	Screw	Recommended Fuse Bussmann UL Certification		Contactor	Circuit Breaker
						Rated Current (A)	Model		
CS710-4T250G(-L)	2 x (3 x 120)	120	2 x (3 x 120)	*	M12	800	FWH-800A	475	630
CS710-4T280G(-L)	2 x (3 x 150)	150	2 x (3 x 150)	*	M12	800	FWH-800A	620	800
CS710-4T315G(-L)	2 x (3 x 185)	185	2 x (3 x 185)	*	M16	1000	170M5016	620	800
CS710-4T355G(-L)	2 x (3 x 185)	185	2 x (3 x 185)	*	M16	1000	170M5016	620	800
CS710-4T400G(-L)	2 x (3 x 240)	240	2 x (3 x 240)	*	M16	1400	170M6017	800	1000
CS710-4T450G(-L)	2 x (3 x 240)	240	2 x (3 x 240)	*	M16	1400	170M6017	800	1000

[1] Chinese standards are applicable. 3 x 10 indicates a 3-core cable, and 2 x (3 x 95) indicates two 3-core cables.

9.4.2 Lug Models and Dimensions

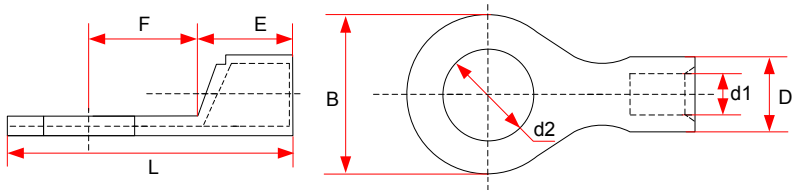

Figure 9-18 Dimensions of TNR series lugs

Table 9-8 Models and dimensions of TNR series lugs

Model	Cable Range		D	d1	E	F	B	d2	L	Current (A)	Crimping Tool
	AWG/MCM	(mm ²)									
TNR0.75-4	22-16	0.25-1.0	2.8	1.3	4.5	6.6	8.0	4.3	15.0	10	RYO-8 AK-1M
TNR1.25-4	22-16	0.25-1.65	3.4	1.7	4.5	7.3	8	5.3	15.8	19	

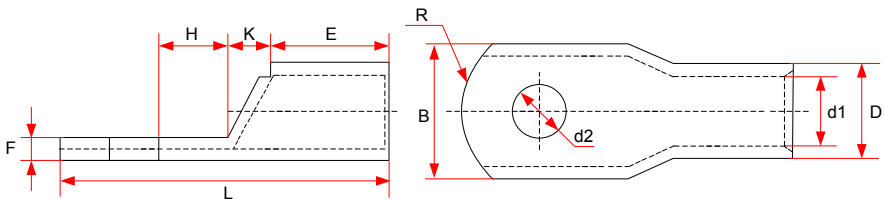

Figure 9-19 Dimensions of GTNR series lugs

Table 9-9 Models and dimensions (mm) of GTNR series lugs

Model	D	d1	E	H	K	B	d2	F	L	R	Crimping Tool
GTNR1.5-5	4.0	2.2	5.0	5.0	2.0	8.0	5.3	1.0	16.0	5	RYO-8 YYT-8 RYO-14
GTNR2.5-4	4.5	2.9	7.0	5.0	2.0	8.0	4.3	1.0	18.0		
GTNR2.5-5				6.0			10.2		5.3	0.8	
GTNR2.5-6	5.2	3.6	7.0		6.0	2.0		10.0	5.3		
GTNR4-6				6.0			4.2	9.0	7.5	3.0	
GTNR6-5	7.0	5.0	9.0		8.0	3.5					
GTNR6-6				7.8			5.8	12.0	8.0	4.0	
GTNR6-8	9.5	7.5	12.0		8.0	4.5					
GTNR10-6				11.4			8.6	15.0	9.0	5.0	
GTNR10-8	12.6	9.6	16.0		11.0	6.0					
GTNR16-6				15.0			12.0	18.0	13.0	7.0	21.0
GTNR16-8	17.4	13.5	20.0		13.0	9.0					25.0
GTNR25-6				19.8			15.0	22.0	14.0	10.0	28.0
GTNR25-8	21.2	16.5	26.0		16.0	11.0					30.0
GTNR25-10				23.5			18.5	32.0	17.0	12.0	34.0
GTNR35-6	26.5	21.5	38.0		20.0	14.0					38.0
GTNR35-8				21.0			12.0	18.0	13.0	7.0	21.0
GTNR35-10	17.4	13.5	20.0		13.0	9.0					25.0
GTNR50-8				19.8			15.0	22.0	14.0	10.0	28.0
GTNR50-10	21.2	16.5	26.0		16.0	11.0					30.0
GTNR70-8				23.5			18.5	32.0	17.0	12.0	34.0
GTNR70-10	26.5	21.5	38.0		20.0	14.0					38.0
GTNR70-12				17.4			13.5	20.0	13.0	9.0	25.0
GTNR95-10	19.8	15.0	22.0		14.0	10.0					28.0
GTNR95-12				21.2			16.5	26.0	16.0	11.0	30.0
GTNR120-12	23.5	18.5	32.0		17.0	12.0					34.0
GTNR120-16				26.5			21.5	38.0	20.0	14.0	38.0
GTNR150-12	17.4	13.5	20.0		13.0	9.0					25.0
GTNR150-16				19.8			15.0	22.0	14.0	10.0	28.0
GTNR185-16	21.2	16.5	26.0		16.0	11.0					30.0
GTNR240-16				23.5			18.5	32.0	17.0	12.0	34.0
GTNR240-20	26.5	21.5	38.0		20.0	14.0					38.0

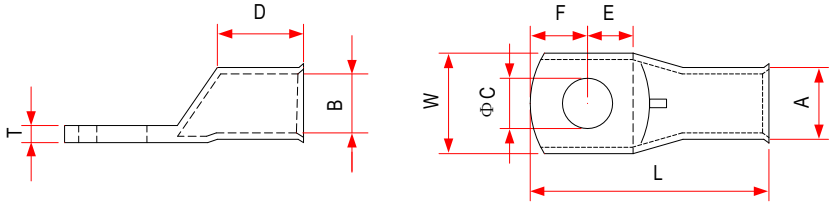

Figure 9-20 Dimensions of BC series lugs

Table 9-10 Models and dimensions (mm) of BC series lugs

Model	A	B	W	E	D	L	T	C	F
120-8	19.0	15.0	27.2	16.5	27.0	73.0	4.0	8.5	16.5
120-10								10.5	
120-12								12.8	
120-14								14.7	
120-16								16.7	
120-20				20.7				14.3	
150-8	21.0	16.5	30.0	16.5	27.0	78.0	4.5	8.5	16.5
150-10								10.5	
150-12								12.8	
150-14								14.7	
150-16								16.7	
150-20				20.7				14.3	
185-10	23	18.5	33.5	16.5	30	82	4.5	10.5	16.5
185-12								12.8	
185-14								14.7	
185-16								16.7	
185-20				20.7				14.3	
240-10	26	21	37.7	18.0	32.0	88.0	5.0	10.5	17.0
240-12								12.8	
240-14								14.7	
240-16								16.7	
240-20								20.7	

Model	A	B	W	E	D	L	T	C	F
300-10	28.0	23.0	41.0	18.0	37.0	97.0	5.0	10.5	17.0
300-12								12.8	
300-14								14.7	
300-16								16.7	
300-20								20.7	

9.4.3 Residual Current Device Selection

Select the residual current device (RCD) according to the following conditions:

- High-frequency leakage current will be generated when the AC drive is running, which may cause malfunction of the RCD. To avoid such a problem, install an RCD of at least 100 mA action current for each AC drive.
- If multiple AC drives share the same RCD, the action current of the RCD must be at least 300 mA.
- Chint's and Schneider's RCDs are recommended.

If the RCD malfunctions, troubleshoot the problem according to the following table.

Table 9-11 Solutions for leakage current

Symptom	Possible Cause	Solution
The RCD trips immediately upon power-on.	The anti-interference capacity of the RCD is poor.	<ol style="list-style-type: none"> 1. Use the recommended RCDs. 2. Replace the RCD with a higher action current. 3. Connect the unbalanced load to the front end of the RCD. 4. Disconnect the EMC screw or the ground end of the external EMC filter to reduce the ground capacitance at the input side.
	The action current of the RCD is too low.	
	The RCD is connected to an unbalanced load at the rear end.	
	The ground capacitance at the front end of the AC drive is large.	

Symptom	Possible Cause	Solution
The RCD trips during running.	The anti-interference capacity of the RCD is poor.	1. Use the recommended RCDs.
	The action current of the RCD is too low.	2. If only a single AC drive is used, check that the EMC screw is tightened.
	The RCD is connected to an unbalanced load at the rear end.	3. If multiple AC drives are used, disconnect the EMC screws, as shown in Figure 9-21.
	The ground distributed capacitance of the motor cable and motor is too large.	4. Add a simple filter at the input side and wind the magnetic ring on the LN and RST cables on the side near the RCD, as shown in Figure 9-22.
		5. Replace an RCD with higher rated action current.
		6. Reduce the carrier frequency on the premise that the performance requirements are met.
		7. Shorten the motor cable.

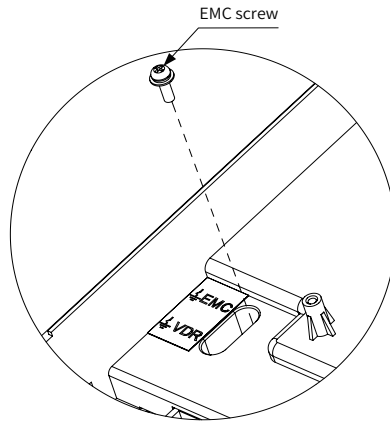

Figure 9-21 Disconnecting the EMC screw

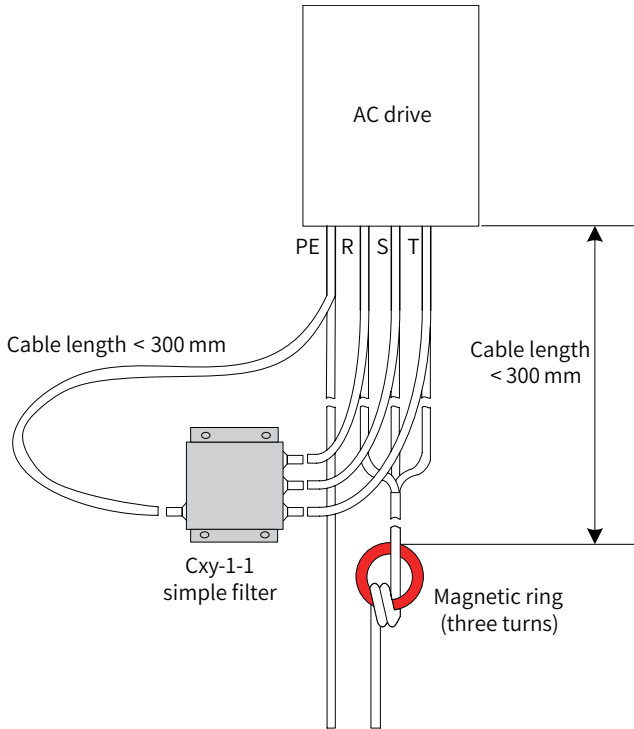

Figure 9-22 Installing a simple filter and magnetic ring at the input side

9.5 Selection of Braking Components

9.5.1 Selection of Braking Units

When selecting the braking unit for an indoor travel mechanism, you need to consider only the short-time permissible braking capability of the braking unit.

$$P_{z\max} = 0.8 \times P_{B\max} \quad (\text{formula 1})$$

In formula 1, $P_{z\max}$ is the short-time permissible power of the braking unit, expressed in kW.

$P_{B\max}$ is the short-time permissible power of the AC drive, expressed in kW.

This formula indicates that the short-time permissible power of the braking unit is 0.8 times the short-time permissible motor power of the AC drive. The constant 0.8 is obtained based on the following prerequisite: The maximum braking power will not exceed the maximum motor power multiplied by square of the mechanical efficiency of the travel mechanism (assuming that the efficiency is 0.9).

When selecting the braking unit for a hoisting mechanism, you need to consider the short-time permissible braking capability and continuous braking capability.

If the hoisting height is low, the rated hoisting speed is high, and the total descending time

is shorter than the time allowed by the short-time permissible overload capability of the braking unit, you can still select the braking unit based on formula 1. However, a margin of 15% to 25% is recommended for the braking power in case the hoisting mechanism needs to perform two full-load descending actions continuously.

If the hoisting height is high, the rated hoisting speed is low, and the total descending time is longer than the time allowed by the short-time permissible overload capacity of the braking unit, select the braking unit based on the continuous braking capability.

$$P_z = 0.8 \times P_D \tag{formula 2}$$

In formula 2, P_z is the continuous braking power of the braking unit, expressed in kW.

P_D is the power of the motor, expressed in kW.

If you select a braking unit based on formula 1, you need to verify its overload capacity based on formula 2.

9.5.2 Selection of Braking Resistors

Generally, select braking resistors with resistance slightly larger than the minimum braking resistance allowed by the AC drive.

When selecting braking resistors for a travel mechanism, calculate the required capacity using formula 2, and then check the maximum current allowed by the selected braking resistor using formula 3.

$$I_{zmax} = \frac{1.15 \times V_{bz}}{R_{sc}} \tag{formula 3}$$

In this formula, I_{zmax} is the maximum current allowed by the braking resistor, expressed in A.

V_{bz} is the braking voltage threshold, expressed in V.

R_{sc} is the resistance of the braking resistor, expressed in Ω .

When selecting braking resistors for a hoisting mechanism, calculate the required capacity using formula 2, and then verify the selection using formula 1.

9.5.3 List of Braking Components

Table 9-12 Recommended braking components

AC Drive Model	Braing Unit	Min. Power for Hoisting (kW)	Min. Power for Travel (kW)	Min. Braking Resistance (Ω)
CS710-4T0.4GB	Built-in	0.2	0.08	96
CS710-4T0.7GB	Built-in	0.35	0.14	96
CS710-4T1.1GB	Built-in	0.55	0.22	96
CS710-4T1.5GB	Built-in	0.75	0.3	96
CS710-4T2.2GB	Built-in	1.1	0.44	64
CS710-4T3.0GB	Built-in	1.5	0.6	64
CS710-4T3.7GB	Built-in	1.8	0.75	32

AC Drive Model	Braking Unit		Min. Power for Hoisting (kW)	Min. Power for Travel (kW)	Min. Braking Resistance (Ω)
CS710-4T5.5GB	Built-in		2.7	1.1	32
CS710-4T7.5GB	Built-in		3.7	1.5	32
CS710-4T11GB	Built-in		5.5	2.2	20
CS710-4T15GB	Built-in		7.5	3	20
CS710-4T18.5GB	Built-in		9	3.7	24
CS710-4T22GB	Built-in		11	4.4	24
CS710-4T30GB	Built-in		15	6	19.2
CS710-4T37GB	Built-in		18	7.5	14.8
CS710-4T45GB	Built-in		22	9	12.8
CS710-4T55GB	Built-in		27	11	9.6
CS710-4T75GB	Built-in		37	15	6.8
CS710-4T90G	Input voltage \leq 440 VAC	MDBUN-200-T	45	18	2.5
CS710-4T90G	Input voltage > 440 VAC	MDBUN-200-5T	45	18	2.5
CS710-4T110G	Input voltage \leq 440 VAC	MDBUN-200-T	55	22	2.5
CS710-4T110G	Input voltage > 440 VAC	MDBUN-200-5T	55	22	2.5
CS710-4T132G	Input voltage \leq 440 VAC	MDBUN-200-T	66	26.4	2.5
CS710-4T132G	Input voltage > 440 VAC	MDBUN-200-5T	66	26.4	2.5
CS710-4T160G	Input voltage \leq 440 VAC	MDBUN-200-T	88	32	2.5
CS710-4T160G	Input voltage > 440 VAC	MDBUN-200-5T	88	32	2.5
CS710-4T200G(-L)	Input voltage \leq 440 VAC	MDBUN-200-T \times 2	50 \times 2	20 \times 2	2.5 \times 2
CS710-4T200G(-L)	Input voltage > 440 VAC	MDBUN-200-5T \times 2	50 \times 2	20 \times 2	2.5 \times 2
CS710-4T220G(-L)	Input voltage \leq 440 VAC	MDBUN-200-T \times 2	55 \times 2	22 \times 2	2.5 \times 2
CS710-4T220G(-L)	Input voltage > 440 VAC	MDBUN-200-5T \times 2	55 \times 2	22 \times 2	2.5 \times 2
CS710-4T250G(-L)	Input voltage \leq 440 VAC	MDBUN-200-T \times 2	63 \times 2	25 \times 2	2.5 \times 2
CS710-4T250G(-L)	Input voltage > 440 VAC	MDBUN-200-5T \times 2	63 \times 2	25 \times 2	2.5 \times 2
CS710-4T280G(-L)	Input voltage \leq 440 VAC	MDBUN-200-T \times 2	70 \times 2	28 \times 2	2.5 \times 2
CS710-4T280G(-L)	Input voltage > 440 VAC	MDBUN-200-5T \times 2	70 \times 2	28 \times 2	2.5 \times 2
CS710-4T315G(-L)	Input voltage \leq 440 VAC	MDBUN-200-T \times 2	80 \times 2	31 \times 2	2.5 \times 2
CS710-4T315G(-L)	Input voltage > 440 VAC	MDBUN-200-5T \times 2	80 \times 2	31 \times 2	2.5 \times 2
CS710-4T355G(-L)	Input voltage \leq 440 VAC	MDBUN-200-T \times 3	60 \times 3	24 \times 3	2.5 \times 3
CS710-4T355G(-L)	Input voltage > 440 VAC	MDBUN-200-5T \times 3	60 \times 3	24 \times 3	2.5 \times 3
CS710-4T400G(-L)	Input voltage \leq 440 VAC	MDBUN-200-T \times 3	67 \times 3	26 \times 3	2.5 \times 3
CS710-4T400G(-L)	Input voltage > 440 VAC	MDBUN-200-5T \times 3	67 \times 3	26 \times 3	2.5 \times 3

AC Drive Model	Braing Unit		Min. Power for Hoisting (kW)	Min. Power for Travel (kW)	Min. Braking Resistance (Ω)
CS710-4T450G(-L)	Input voltage ≤ 440 VAC	MDBUN-200-T×3	75×3	30×3	2.5×3
CS710-4T450G(-L)	Input voltage > 440 VAC	MDBUN-200-5T×3	75×3	30×3	2.5×3



NOTE

- ◆ In the preceding table, x 2 or x3 indicate that two or three braking units with their respective braking resistors are connected in parallel mode.
- ◆ Default initial braking voltages of various braking units are:
 Built-in braking units: 660 V
 MDBUN-60-T, MDBUN-90-T, MDBU-200-T: 670 V, used when supply input voltage ≤ 440 VAC
 MDBUN-60-5T, MDBUN-90-5T, MDBU-200-5T : 760 V, used when supply input voltage > 440 VAC
- ◆ The initial braking voltage can be adjusted depending on the supply voltage. If you increase the initial braking voltage, the braking resistance also increases.
- ◆ The minimum braking resistance values listed in the preceding table are minimum values allowed by braking units. If the resistance of a braking resistor is smaller than the minimum value, the braking unit may experience overcurrent.
- ◆ The resistor power for hoisting application is 1/2 of the motor power, and that for travel application is 1/4 of the motor power. (The default motor power is the same as the drive power.)
- ◆ Data provided in the table is for reference only. You can select resistance and power of braking resistors based on actual needs. The resistance must not be lower than the reference value, while the power can be higher than the reference value. Select braking resistors based on the regenerated power by the motor in the actual system. You need to consider the system inertia, deceleration time and load potential energy. For systems with high inertia, short deceleration time, and frequent braking, select a braking resistor with higher power and lower resistance value.

9.5.4 External and Installation Dimensions of Braking Units

For details about the external and installation dimensions of the MDBUN braking unit, see 19011140 MDBUN Series Braking Unit User Guide.

9.6 Mounting Dimensions of External Operating Panels

MD32NKE1 (optional part) is the external operating panel applicable to a CS710 series AC drive. It adopts the LED display and has the same operation mode as the operating panel on the AC drive. This external part facilitates AC drive commissioning. The following figure shows its appearance and mounting dimensions.

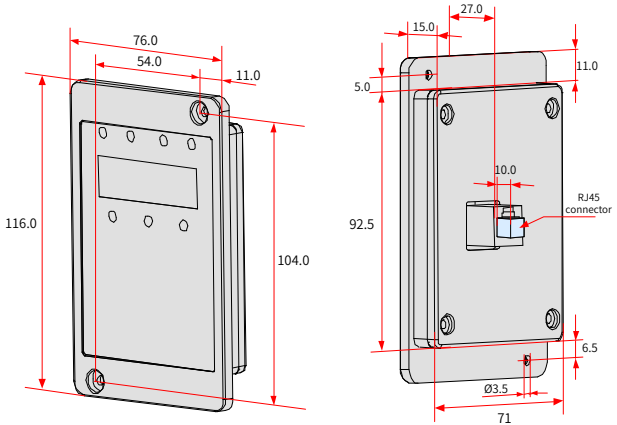

Figure 9-23 MD32NKE1 dimensions (mm)

10 Options

10.1 Extension I/O Cards

10.1.1 Multi-functional Extension I/O Card (MD38IO1)

(Applicable to models of 15 kW and higher ratings)

MD38IO1 is a multi-functional extension I/O card designed for CS710 series AC drives. It provides five DI terminals, one AI terminal, one AO terminal, one relay output terminal, as well as CAN and RS-485 ports for bus control.

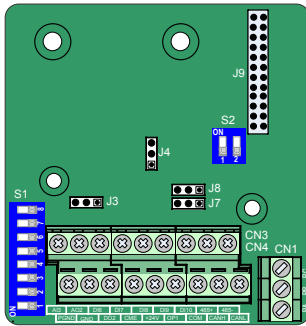

Figure 10-1 Terminal layout on MD38IO1

Table 10-1 Description of terminals on MD38IO1

Identifier	Terminal Name	Description	Layout
CN4	+24V/COM	External 24 VDC power supply	
	OP1	Digital input power terminal	
	DO2-CME	Digital output 2	
	CANH/ CANL/ COM	Communication port terminal	
CN3	AI3-PGND	Analog input 3	
	AO2-GND	Analog output 2	
	DI6-OP1 to DI10-OP1	Five digital inputs	
	485+/485-/ COM	Communication terminals	
CN1	PA-PB	Normally-closed (NC) terminal	 PA PB PC
	PA-PC	Normally-opened (NO) terminal	



◆ RS-485 communication terminals 485+/485-/COM and CANlink communication terminals CANH/CANL/COM are completely independent and can be used simultaneously.

Table 10-2 Description of jumpers on MD38IO1

Identifier	Terminal Name	Description	Jumper/DIP Switch Setting
J3	AO2 output type selection	Voltage: 0–10 V	
		Current: 0–20 mA	
J4	CAN termination resistor connection selection	Termination resistor connected	
		Termination resistor not connected	
J7	CME connection mode selection	CME and COM shorted	
		CME and 24V shorted	
J8	OP1 connection mode selection	OP1 and COM shorted	
		OP1 and 24V shorted	
S2	RS-485 termination resistor connection selection	1 and 2 set to ON: termination resistor connected	
		1 and 2 set to OFF: termination resistor not connected	
S1	AI3, PT100, and PT1000 selection	AI3: 1, 2, and 3 set to ON	
		PT1000: 4, 5, and 6 set to ON	
		PT100: 6, 7, and 8 set to ON	

**NOTE**

- ◆ The preceding jumper setting figures are top views of an extension card with main terminals at the bottom. Jumpers are identified by silkscreens on the card.

10.1.2 Mini I/O Extension Card (MD38IO2)

(Available to all models)

MD38IO2 is a simplified version of MD38IO1 and provides three DI terminals.

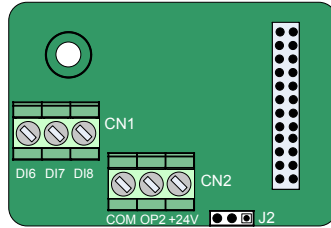



Figure 10-2 Terminal layout on MD38IO2

Table 10-3 Description of terminals on MD38IO2

Identifier		Terminal Name	Description	Layout
CN2	+24V/COM	External +24 VDC power supply	1. Provides +24 V power supply to external devices, generally DI/DO terminals and sensors. 2. Maximum output current: 200 mA	 COM OP2 +24V
	OP2	Digital input power terminal	OP2 is not connected to a power supply by default and can be connected to an external power or +24V as required.	
CN1	DI6-OP2 to DI8-OP2	Three digital inputs	1. Optically-coupled isolation, compatible with bipolar inputs 2. Input resistance: 3.3 kΩ for DI6 and DI7, 2.4 kΩ for DI8 3. Voltage range for input active level: 9–30 V 4. DI6, DI7 and DI8 are common input terminals with input frequency less than 100 Hz.	 DI6 DI7 DI8

Table 10-4 Description of jumpers on MD38IO2

Identifier	Terminal Name	Description	Jumper/DIP Switch Setting
J2	OP2 connection mode selection	If DI connected in SINK mode, OP2 connected to +24V	
		If DI connected in SOURCE mode, OP2 connected to COM	



NOTE

◆ The preceding jumper setting figures are top views of an extension card with main terminals at the bottom. Jumpers are identified by silkscreens on the card.

10.1.3 Terminal Arrangement and Functions of MD38IO3

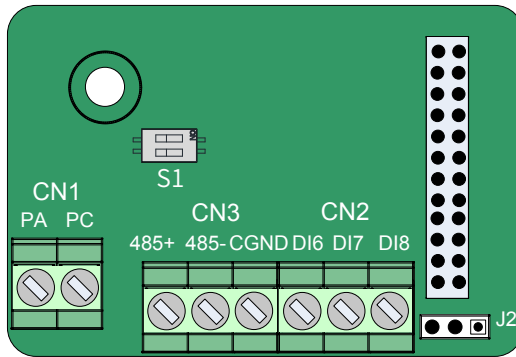
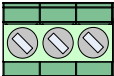

Figure 10-3 Terminal arrange of MD38IO3

Table 10-5 Terminal functions of MD38IO3

Identifier	Terminal Name	Description	Terminal Figure
CN3	485+	485 communication signal (+)	 <p>CN3 485+ 485- CGND</p>
	485-	485 communication signal (-)	
	CGND	485 communication signal ground	
		The Modbus protocol is supported. Isolated input is adopted.	





Identifier		Terminal Name	Description	Terminal Figure
CN2	DI6 to DI8	Three digital inputs	1. Optically-coupled isolation compatible with dual-polarity inputs; maximum input frequency: 100 Hz 2. Input impedance: 3.4 k Ω 3. Voltage range for level input: 9–24 V	
CN1	PA-PC	NO terminal	Contact driving capacity: 250 VAC/5 A 30VDC/5A	
S1	RS485 termination resistor selection	Two-bit DIP switch	Connect the termination resistor when switches 1 and 2 are turned on. Disconnect the termination resistor when switches 1 and 2 are turned off.	

Table 10-6 Jumpers of MD38IO3

Identifier	Terminal Name	Description	Jumper/DIP Switch Setting
J2	DI terminal connection mode	When the DI terminal is connected in the SINK mode, OP is connected to 24V.	
		When the DI terminal is connected in the SOURCE mode, OP is connected to COM.	

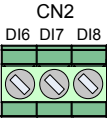
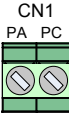
**NOTE**

- ◆ For the setting of jumpers, the top view with main wiring terminals at the bottom of the extension card is the visual angle. Jumpers are printed on the extension card. Please take the printing as the standard.

10.1.4 Multi-functional Extension I/O Card (CS700IO1)

(Applicable to models of 11 kW and lower ratings)

CS700IO1 provides two DI terminals, one relay output terminal, and one RS-485 communication terminal.

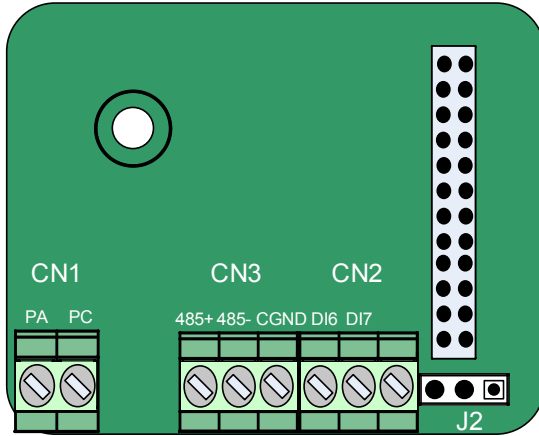

Figure 10-4 Terminal layout on CS700IO1

Table 10-7 Description of terminals on CS700IO1



Identifier		Terminal Name	Description	Layout
J2	+24V/COM	External +24 VDC power supply	1. Provides +24 V power supply to external devices, generally DI/DO terminals and sensors. 2. Maximum output current: 200 mA	 J2
CN2	DI6-COM to DI7-COM	Two digital inputs	1. Optically-coupled isolation, compatible with bipolar inputs 2. Input resistance: 2.4 kΩ 3. Voltage range for input active level: 9–30 V	DI6 DI7 
CN3	485+/485-/CGND	Communication terminals	Modbus-RTU communication terminals, isolated input	485+ 485- CGND 
CN1	PA- PC	NO terminal	Contact driving capacity: AC: 250 V, 3 A, COSφ = 0.4 DC: 30 V, 1 A	PA PC 

Table 10-8 Description of jumpers on CS700I01

Identifier	Terminal Name	Description	Jumper/DIP Switch Setting
J2	DI terminal connection mode	The DI terminals on the extension card are connected in the SINK mode.	
		The DI terminals on the extension card are connected in the SOURCE mode.	
		An external 24 V power supply is connected to the DI terminal.	Remove the jumper cap.

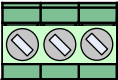
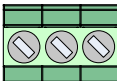
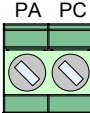

- ◆ The preceding jumper setting figures are top views of an extension card with main terminals at the bottom. Jumpers are identified by silkscreens on the card.

10.1.5 Multi-functional Extension I/O Card (CS700RC2)

(Applicable to models of 15 kW and higher ratings)

CS700RC2 provides three DI terminals, two relay output terminals, and one RS-485 communication terminal.

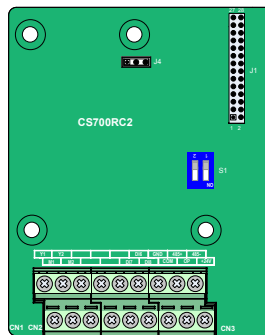

Figure 10-5 Terminal layout on CS700RC2

Table 10-9 Description of terminals on CS700RC2

Identifier		Terminal Name	Description	Layout
Power	+24V~COM	External 24 VDC power supply	1. Provides +24 V power supply to external devices, generally DI/DO terminals and sensors. 2. Maximum output current: 200 mA	
	OP	Digital input power terminal	1. Connects to the +24V terminal by jumper J8 by default. 2. When using an external power supply, remove jumper J8 and connect OP to the external power supply.	
Relay output terminals	Y1~M1 Y2~M2	Relay output	Contact driving capacity: AC: 250 V, 5 A, COS ϕ = 0.4 DC: 30 V, 1 A	
DI terminals	DI6~OP DI7~OP DI8~OP	Digital input	1. Optically-coupled isolation, compatible with bipolar inputs 2. Input resistance: 2.4 k Ω 3. Voltage range for input active level: 9–30 V	
RS-485 communication	485+ 485-GND	RS485 communication terminals	Shielded twisted pairs are recommended. See the RS-485 communication protocol of CS700 for reference.	
DIP switch	S1	RS-485 termination resistor connection selection	Connection of the RS-485 termination resistor, which is not connected by default upon delivery	



NOTE

◆ The preceding jumper setting figures are top views of an extension card with main terminals at the bottom. Jumpers are identified by silkscreens on the card.

10.2 Communication Extension Cards

10.2.1 CANopen Extension Card (MD38CAN2)

(Available to all models)

MD38CAN2 is designed for CANopen communication and has the following characteristics:

- Supports the Node Guard protocol, which enables the master station to obtain the equipment status.
- Has four input process data object (PDO) channels and four output PDO channels. The output PDO channels support synchronous and asynchronous transmission.
- Supports expedited transfer of service data object (SDO) and allows at most 4 bytes to be transferred each time.
- Does not support emergency objects.
- Ensure that electrical parameters for CANopen communication comply with international standards.

1 Appearance of MD38CAN2

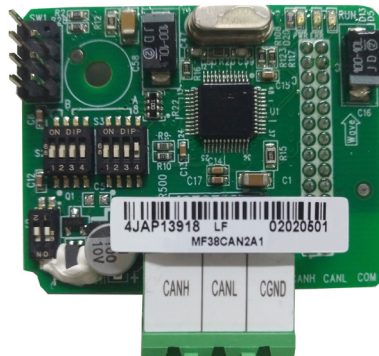

Figure 10-6 MD38CAN2 appearance

2 Terminal Function Description

Table 10-10 Terminal function description

Type	Identifier	Terminal Name	Description
CAN communication (CN1)	CANH/CANL	Communication terminals	CANlink communication terminals with isolated input
	COM	CAN communication power ground	Connected to the common mode choke of +24 V power ground
Program burning	SW1	ARM program burning interface	

3 DIP Switch Definition

The two-bit DIP switch S1 of the MD38CAN2 is used to configure the CAN bus termination resistor. It is recommended that termination resistors be connected at both ends of the network. In the table below, when the DIP switch is set to ON, it is indicated as 1; when it is set to the other position, it is indicated as 0.

DIP Switch No.		Termination Resistor
1	2	
0	0	Not connected
1	1	Connected

Caution: In the CANopen communication mode, the AC drive located at the end of the network should have the termination resistors connected.

The DIP switches S2 and S3 of MD38CAN2 consist an 8-bit DIP switch for setting the CAN bus baud rate and communication device address. The following figure shows the DIP switch numbers, in which 1 and 2 are used for setting the baud rate and 3 to 8 are used for setting the CANopen address. In the following table, when the DIP switch is set to ON, it is indicated as 1; when it is set to the other position, it is indicated as 0.

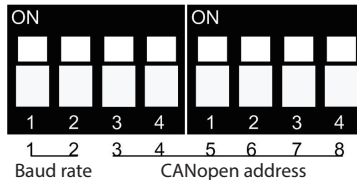

Figure 10-7 MD38CAN2 DIP switches

Bit No.	Function	Description		
1-2	CAN bus baud rate	Bit 1	Bit 2	Baud rate
		0	0	125 kbit/s
		0	1	250 kbit/s
		1	0	500 kbit/s
		1	1	1000 kbit/s
3-8	CANopen network ID	The six binary bits can form 64 addresses, ranging from 0 to 63.		
		Address	DIP Switch Setting	
		0	00 0000	
		7	00 0111	
		20	01 0100	

4 Definition of PDO Data and Parameter Addresses

1) RPDO data definition

RPDO Definition		
RPDO1	AC drive control commands	Bit 0: Decelerate to stop; Bit 1: Coast to stop Bit 2: Forward RUN; Bit 3: Reverse RUN Bit 4: Quick stop; Bit 5: Torque control Bit 6: Reset up fault; Bit 7: Command enabled Bits 8 to 15: Reserved
	Target frequency	The target reference can be set in two modes, determined by bd.06. 1. When the lowest bit of bd.06 is set to 0, the target reference is set to a percentage (default mode). In this mode, the value range of the target reference is 0 to 10000, corresponding to 0.00% to 100.00% of the maximum frequency (positive and negative values not distinguished). 2. When the lowest bit of bd.06 is set to 1, the target reference is set to a specific value. In this mode, the value range of the target reference is 0 Hz to the maximum frequency (positive and negative values not distinguished).
	bd.11	These ten parameters are used to write the value to the corresponding RAM position of the specified parameter.
	bd.12	
RPDO2	bd.13	The parameter address where the value is written is specified by bd.11 to bd.20.
	bd.14	For example, if bd.11 is set to b5.00 and 500 is written into the third parameter of RPDO1, the value of b5.00 will change into 500. Note:
	bd.15	
	bd.16	All parameter addresses of CS710 series AC drives are defined following a unified rule. That is, the group number of a parameter is the high bit of its address, and the hexadecimal value converted from the parameter number forms the low bits of the address. For example, the address of A0.05 is 0xa005, and the address of b3.18 is 0xb312. Addresses of group U parameters have a "d" followed by the group number. For example, the address of U0.18 is 0xd012. PDO data can be configured using the eds file of CS710 series AC drives. Obtain the latest eds file from Inovance.
bd.17		
RPDO3	bd.18	
	bd.19	
	bd.10	

2) TPDO Data Definition

RPDO Definition		
TPDO1	Drive status	Bit 0: AC drive running; Bit 1: AC drive running in forward direction Bit 2: AC drive running in reverse direction; Bit 3: AC drive healthy Bit 4: Coast to stop; Bit 5: No communication with the AC drive Bit 6: Target frequency reached; Bit 7: Torque control enabled Bits 8 to 15: Reserved
	Feedback frequency	Current running frequency
	bd.21	These ten parameters are used to obtain the value of the specified parameter. The parameter address is specified by bd.11 to bd.20.
	bd.22	
TPDO2	bd.23	For example, if bd.21 is set to b5.00, the third parameter of TPDO1 is assigned the actual value of b5.00. Note: All parameter addresses of CS710 series AC drives are defined following a unified rule. That is, the group number of a parameter is the high bit of its address, and the hexadecimal value converted from the parameter number forms the low bits of the address. For example, the address of A0.05 is 0xa005, and the address of b3.18 is 0xb312. Addresses of group U parameters have a "d" followed by the group number. For example, the address of U0.18 is 0xd012.
	bd.24	
	bd.25	All parameter addresses of CS710 series AC drives are defined following a unified rule. That is, the group number of a parameter is the high bit of its address, and the hexadecimal value converted from the parameter number forms the low bits of the address. For example, the address of A0.05 is 0xa005, and the address of b3.18 is 0xb312. Addresses of group U parameters have a "d" followed by the group number. For example, the address of U0.18 is 0xd012.
	bd.26	
TPDO3	bd.27	All parameter addresses of CS710 series AC drives are defined following a unified rule. That is, the group number of a parameter is the high bit of its address, and the hexadecimal value converted from the parameter number forms the low bits of the address. For example, the address of A0.05 is 0xa005, and the address of b3.18 is 0xb312. Addresses of group U parameters have a "d" followed by the group number. For example, the address of U0.18 is 0xd012.
	bd.28	
	bd.29	TPDO data can be configured using the eds file of CS710 series AC drives. Obtain the latest eds file from Inovance.
	bd.30	

10.2.2 RS-485 Extension Card (MD38TX1)

(Available to all models)

MD38TX1 is designed to provide the RS-485 communication function for CS710 series AC drives. It uses an isolation design with electrical parameters in compliance with international standards. You can use this extension card to control the AC drive and set parameters remotely through the RS-485 serial port on the card.

For details about this extension card, see the CS710 Serial Communication Protocol. You can view the document on Inovance website www.inovance.com or obtain it from a local Inovance office or agent.

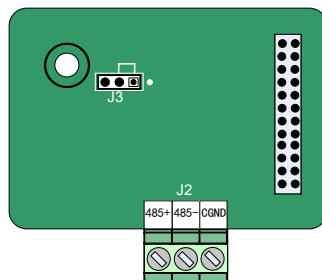

Figure 10-8 Terminal layout on MD38TX1

Table 10-12 Description of terminals on MD38TX1



Identifier	Terminal Name	Description	Layout
CN1	485+	Positive RS-485 communication signal	
	485-	Negative RS-485 communication signal	
	CGND	RS-485 communication reference ground	

Table 10-13 Description of jumpers on MD38TX1

Identifier	Terminal Name	Description	Jumper/DIP Switch Setting
J3	RS-485 termination resistor connection selection	Termination resistor connected	
		Termination resistor not connected	

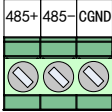

- ◆ In the RS-485 communication mode, the AC drive located at the end of the network should have the termination resistors connected (jumper J3 connected).
- ◆ To prevent external interference to the communication, use a shielded twisted pair as the RS485 communication cable. Straight-through cables are not recommended for this communication mode.

10.2.3 PROFIBUS-DP Extension Card (MD38DP2)

The Inovance PROFIBUS-DP extension card is used to connect a CS710 AC drive to the PROFIBUS-DP bus. It provides data switching to implement all functions of the AC drive, including function configuration, parameter updating, control signal transmission, monitoring, and diagnosis.

This card is compatible with standard PROFIBUS-DP bus and can be used to control an Inovance AC drive through a PROFIBUS-DP bus.

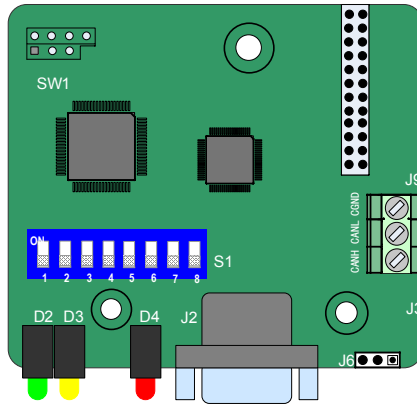

Figure 10-9 Terminal layout on MD38DP2

Table 10-14 Description of terminals on MD38DP2

Terminal Name	Pin No.	Pin Definition	Description	Layout
PROFIBUS-DP communication terminal (J2)	1, 2, 7, 9	NC	Vacant internally	
	3	Data cable B	Positive of data cable	
	4	RTS	Request-to-send signal	
	5	GND	Isolated 5 V power ground	
	6	+5V	Isolated 5 V power supply	
	8	Data cable A	Negative pole of data cable	
CANlink communication terminal (J3, J9)	CANH	CAN positive input	Positive of data cable	
	CANL	CAN negative input	Negative of data cable	
	GND	Power ground	Isolated 5 V power ground	

Table 10-15 Description of jumpers on MD38DP2



Identifier	Terminal Name	Description	Jumper/DIP Switch Setting
J6	CANlink termination resistor connection selection	Termination resistor connected	
		Termination resistor not connected	

Table 10-16 Description of indicators on MD38DP2









Indicator	State	Description
Power supply indicator (D4)	 D4	On: The card is powered on normally.
	 D4	Off: The card cannot be powered on. Check whether it is installed correctly.
PROFIBUS-DP card and master station communication indicator (D3)	 D3	On: The PROFIBUS-DP card is communicating with the PROFIBUS-DP master station normally.
	 D3	Blinking: The PROFIBUS-DP master station is not running or an error occurs in communication between the master station and DP card.
	 D3	Off: The PROFIBUS-DP card is not communicating with the PROFIBUS-DP master station. (Check the PROFIBUS-DP cable connection and master station ID.)
PROFIBUS-DP card and AC drive communication indicator (D2)	 D2	On: The PROFIBUS-DP card is communicating with the AC drive normally.
	 D2	Blinking: The PROFIBUS-DP card cannot communicate with the AC drive. (Check whether the baud rate is set correctly.)
	 D2	Off: There is interference to communication between the PROFIBUS-DP card and AC drive, or the address of the PROFIBUS-DP card is not in the range of 1 to 125.

Table 10-17 DIP switch on MD38DP2

PROFIBUS-DP Slave Address Setting								Slave Station Address	DIP Switch	
1	2	3	4	5	6	7.	8			
PROFIBUS-DP card model selection, which defaults to OFF: MD38DP2	0	0	0	0	0	0	0	Reserved		
	0	0	0	0	0	0	1	1		
	0	0	0	0	0	0	1	0		2
	0	0	0	0	0	0	1	1		3

	1	1	1	1	1	1	0	1		123
	1	1	1	1	1	1	1	0		124
1	1	1	1	1	1	1	1	125		

**NOTE**

- ◆ When DIP bit 1 is set to ON, the card model is MD38DP1. Change of this bit takes effect after the card is powered on again. Changes of slave address DIP switches take effect immediately.

10.2.4 PROFINET Communication Extension Card (MD500-PN1)

(Available to all models)

The MD500-PN1 extension card is a PROFINET fieldbus adapter card, which meets the international PROFINET Ethernet standards.

This card can be used on the AC drive to increase the communication efficiency and implement the AC drive networking function, which enables the AC drive to be a slave controlled by the field bus master station.

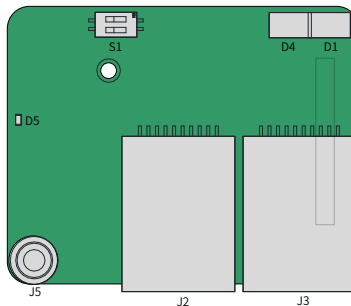

Figure 10-10 Terminal arrangement of MD500-PN1

Table 10-18 Hardware description of MD500-PN1

Identifier	Hardware Name	Function Description
J1	Pin header	Used to connect the AC drive.
J2	Network port	Used to communicate with the PROFINET card (PLC), direction insensitive.
J3		
J5	EMC ground terminal	Used to connect the EMC ground terminal of the AC drive.
D5	Power indicator	Used to indicate the power status. On: power-on normal Off: power-on abnormal (Check whether the installation is correct.)
D1	PLC communication status indicator (PLCLINK)	Steady on in green: communication normal Blinking in green: master station not found (Check the configuration to see whether a device name is assigned for the slave device. Check whether the corresponding PLC is connected.) Steady on in yellow: configuration incorrect (Check whether the GSD is correct.) Steady on in red: communication with the master lost (Check whether the wiring is correct.)
D4	AC drive communication status indicator (DSPLINK)	Steady on in green: normal Steady on in yellow: MAC address is abnormal (Replace the MD500-PN1 card.) Blinking in yellow: AC drive faulty (Clear the AC drive fault.) Steady on in red: communication with the AC drive abnormal (Set F0-28 to 1 and check whether the AC drive supports the MD500-PN1 card.)
S1	Two-bit DIP switch	Used for upgrade by the manufacturer only.

**NOTE**

- ◆ After the MD500-PN1 card is installed, J2 is on the left and J3 is on the right when facing to the RJ45 interface. The Cat5e shielded twisted pair (STP) network cable is recommended for ensuring stability.
- ◆ For details about the MD500-PN1 card, see 19011287 MD500 Series PROFINET Extension Card User Guide.

10.2.5 PZD Process Data Description and Parameter Address Definition

1 PZD Zone Data Definition

PZD Zone Data Sent by the Master Station	
PZD1	Bit 0: Decelerate to stop; Bit 1: Coast to stop Bit 2: Forward RUN; Bit 3: Reverse RUN Bit 4: Quick stop; Bit 5: Torque control Bit 6: Reset up fault; Bit 7: Command enabled Bits 8 to 15: Reserved
PZD2	It is used to set the target frequency of the AC drive. (The reference source must be set to serial communication.) The target reference can be set in two modes, determined by bd.06. 1. When the lowest bit of bd.06 is set to 0, the target reference is set to a percentage (default mode). In this mode, the value range of the target reference is 0 to 10000, corresponding to 0.00% to 100.00% of the maximum frequency (positive and negative values not distinguished). 2. When the lowest bit of bd.06 is set to 1, the target reference is set to a specific value. In this mode, the value range of the target reference is 0 Hz to the maximum frequency (positive and negative values not distinguished).
PZD3-PZD12	The ten parameters are used to write the value to the corresponding RAM position of the specified parameter. The address where the value is written is specified by bd.11 to bd.20. For example, if bd.11 is set to B5.00 and value 500 is written in PZD3, the value of B5.00 changes to 5.00. Parameter addresses can also be configured using the device-specific parameters (PLC slave station attributes). If a parameter address is specified by a device-specific parameter, it overrides the address specified by bd.11 to bd.20. For details, see sub-section 4 "Device-specific Parameter Setting".
PZD Returned by the Slave Station	
PZD1	Bit 0: AC drive running; Bit 1: AC drive running in forward direction Bit 2: AC drive running in reverse direction; Bit 3: AC drive healthy Bit 4: Coast to stop; Bit 5: No communication with the AC drive Bit 6: Target frequency reached; Bit 7: Torque control enabled Bits 8 to 15: Reserved
PZD2	Used to return the current running frequency of the AC drive. For example, if 2500 is returned, the current running frequency of the AC drive is 25.00 Hz.

PZD Zone Data Sent by the Master Station	
PZD3-PZD12	<p>Used to return the current value of the corresponding parameter address. The parameter address is specified by bd.21 to bd.30. For example, if bd.21 is set to b5.01 and the current value of b5.01 is 25.00, the return value of PZD3 is 2500.</p> <p>Parameter addresses can also be configured using the device-specific parameters (PLC slave station attributes). If a parameter address is specified by a device-specific parameter, it overrides the address specified by bd.21 to bd.30. For details, see sub-section 4 "Device-specific Parameter Setting".</p>

2 PKW Zone Data Definition

PKW Zone Data Sent by the Master Station	
PKE	<p>Higher 4 bits: Command code 0: No request 1: Read parameter data 2: Modify parameter data Lower 4 bits: Reserved Lower 8 bits: High bits of parameter address</p>
IND	<p>Higher 8 bits: Low bits of parameter address Lower 8 bits: Reserved</p>
PWE	<p>Higher 16 bits: Reserved Lower 16 bits: Not used in a read request and indicates a parameter value in a write request</p>
PKW Zone Data Sent by the Slave Station	
PKE	<p>Higher 4 bits: Response code 0: No request 1: Correct operation on parameters 7: Operation cannot be executed Lower 8 bits: High bits of parameter address</p>
IND	<p>Higher 8 bits: Low bits of parameter address Lower 8 bits: Reserved</p>
PWE	<p>Request succeeds: Parameter value Request fails: Error code (same as Modbus) 1: Invalid command 2: Invalid address 3: Invalid data 4: Other errors</p>

3 CS710 PROFIBUS-DP Communication Parameter Address Definition

CS710 Parameter Address Definition	
Range: A0.00-FF.99	<p>All parameter addresses of CS710 series AC drives are defined following a unified rule. That is, the group number of a parameter is the high bit of its address, and the hexadecimal value converted from the parameter number forms the low bits of the address.</p> <p>Example 1: Parameter A0.05 indicates the rated speed of the motor, and its address is A005.</p> <p>Example 2: Parameter b3.18 indicates the FM output function, and its address is B312.</p> <p>Note: Addresses of parameters in group U start with D. For example, the address of U0.00 is D000, and the address of U0.12 is D00C.</p>

4 Device-specific Parameter Setting

Device-specific parameters are included in slave station attributes, as shown in the following figure. You can use these parameters to set addresses of PZD3 to PZD12.

For details about parameter addresses, see sub-section 3 "CS710 Parameter Address Definition." By default, addresses of all parameters are 65535, that is, 0xffff in hexadecimal notation. After you set these parameters, their values are displayed in hexadecimal notation.

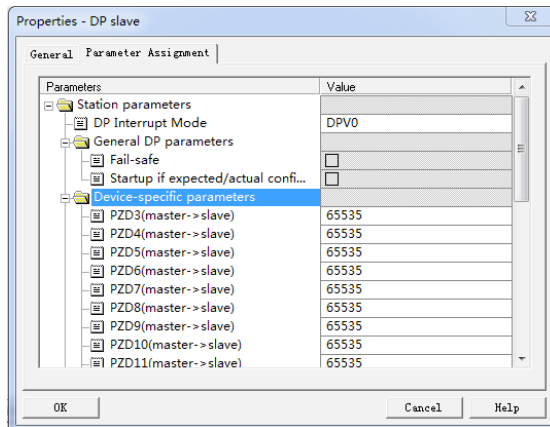

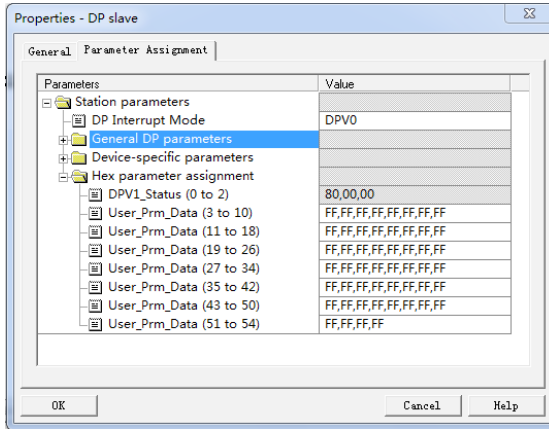

Example: Write the value of A0.05 into PZD3 sent from the master station to the slave station, and write the value of b3.18 into PZD4.

Read the value of b5.00 from PZD3 sent from the slave station to the master station, and read the value of b5.01 from PZD4.

The address of A0.05 is 0xA005 (40965 in decimal notation). The address of b3.18 is 0xB312 (45842 in decimal notation). The address of b5.00 is 0xB500 (46336 in decimal notation). The address of b5.01 is 0xB501 (46337 in decimal notation). The following figure shows the preceding settings.

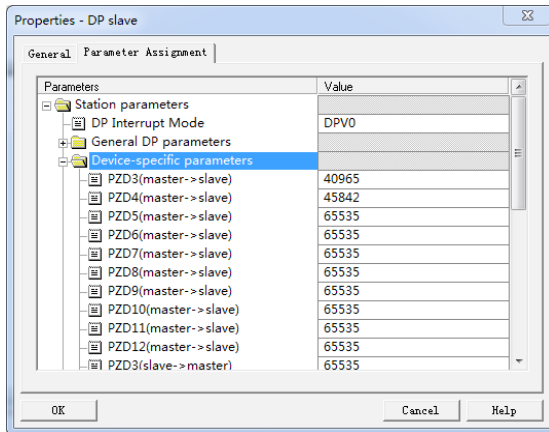

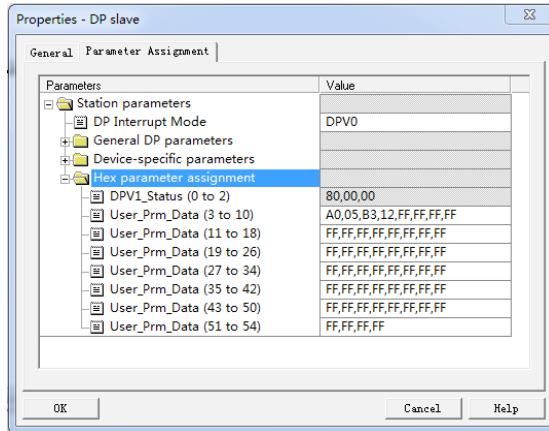

- ◆ After you set device-specific parameters, settings of bd.11 to bd.30 will automatically change in accordance with device-specific parameter settings after the next power-on.

10.3 Encoder Extension Cards

10.3.1 Specifications of Encoder Extension Cards

MD38PGMD

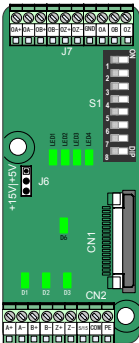

MD38PGMD Specifications	
Encoder power supply	5 V/200 mA, 15 V/100 mA
Maximum input frequency	Differential: 500 kHz; Open-collector: 100 kHz
Encoder interface type	Differential, open-collector, push-pull
Frequency dividing interface type	Support differential, open-collector
Cable specification	16–26 AWG For the details, see " 10.3.2 Multi-functional PG Card (MD38PGMD) ".
Clearance	3.5 mm
Screw	Flathead
User interface	Oblique terminal block
Frequency dividing	0–63

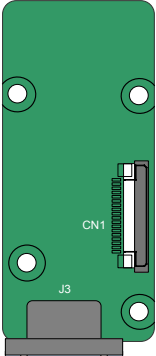

MD38PG4 Specifications	
User interface	DB9 female socket
Plug and play	Yes
Cable specification	> 22 AWG
Resolution	12-bit
Excitation frequency	10 kHz
VRMS	7 V
VP-P	3.15±27%
Frequency dividing	Without frequency dividing function

MD38PG4

10.3.2 Multi-functional PG Card (MD38PGMD)

Table 10-19 Description of terminals on MD38PGMD

Identifier		Description	Layout
CN2	A+	Encoder output signal A positive	
	A-	Encoder output signal A negative	
	B+	Encoder output signal B positive	
	B-	Encoder output signal B negative	
	Z+	Encoder output signal Z positive	
	Z-	Encoder output signal Z negative	
	5V/15V	Encoder 5 V/15 V power supply	
	COM	Encoder power ground	
	PE	Shield connecting point	

Identifier		Description	Layout
J7	OA+	Differential frequency dividing output signal A positive	
	OA-	Differential frequency dividing output signal A negative	
	OB+	Differential frequency dividing output signal B positive	
	OB-	Differential frequency dividing output signal B negative	
	OZ+	Differential frequency dividing output signal Z positive	
	OZ-	Differential frequency dividing output signal Z negative	
	GND	Frequency dividing output reference ground	
	OA	Open-collector frequency dividing output signal A	
	OB	Open-collector frequency dividing output signal B	
	OZ	Open-collector frequency dividing output signal Z	
CN1	18-pin FFC interface, connecting to J4 on the control board of the AC drive		

Table 10-19 Description of DIP switches on MD38PGMD







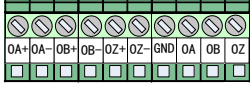



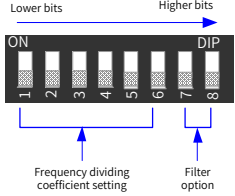

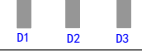





Filter Selection		Definition	Address Setting					Value	Frequency Dividing Coefficient	DIP Switch	
8	7		6	5	4	3	2				1
0	0	Non-self-adaptive filter	0	0	0	0	0	0	Reserved	No output	
			0	0	0	0	0	1	1	1	
0	1	Self-adaptive filter	0	0	0	0	1	0	2	Frequency divided by 2	
			0	0	0	0	1	1	3	Frequency divided by 3	
1	0	Fixed inter-lock	...					61	Frequency divided by 61		
1	1	Automatic inter-lock	1	1	1	1	1	0	62	Frequency divided by 62	
			1	1	1	1	1	1	63	Frequency divided by 63	

Table 10-20 Description of indicators on MD38PGMD

Indicator	State	Indication
D1/D2/D3 Encoder input signal indicator		On or blinking: The encoder has signal input.
		Off: The encoder does not have signal input.
D6 Power supply indicator		On: The power supply is normal.
		Off: No power supply is connected.
LED1 Encoder input signal quality indicator		Off: Input signals are normal. The motor is running at stable speed without interference.
		On: Input signals are slightly unstable, which occurs when the motor is accelerating or decelerating or when encoder signal input suffers slight interference.
		Blinking slowly: Input signals are moderately unstable, which occurs when the motor is accelerating or decelerating or when encoder signal input suffers moderate interference.
		Blinking quickly: Input signals are seriously unstable, which occurs when the motor is accelerating or decelerating quickly or when encoder signal input suffers severe interference.
LED2 PG card signal quality indicator		Off: Signals of the PG card are normal. The motor is running at stable speed without interference.
		On: Signals of the PG card are slightly unstable, which occurs when the motor is accelerating or decelerating or when the PG card does not filter out all interference pulses in encoder input signals. (Less than 10 interference pulses are not filtered per time unit.)
		Blinking slowly: Signals of the PG card are moderately unstable, which occurs when the motor is accelerating or decelerating or when the PG card does not filter out all interference pulses in encoder input signals. (Less than 30 interference pulses are not filtered per time unit.)
		Blinking quickly: Signals of the PG card are seriously unstable, which occurs when the motor is accelerating or decelerating or when the PG card does not filter out all interference pulses in encoder input signals. (More than 30 interference pulses are not filtered per time unit.)
LED3 Inter-lock state indicator		Off: Inter-lock is disabled.
		On: Inter-lock is enabled.

Indicator	State	Indication
LED4 System state indicator	 LED4	Off: The system is not operating or abnormal.
	 LED4	Blinking: The encoder cable is disconnected.
	 LED4	On: The system is working normally.

10.3.3 Resolver PG Card (MD38PG4)

Table 10-21 Description of terminals on MD38PG4





Identifier	Pin No.	Pin Definition	Description	Layout
J3	1	EXC1	Resolver excitation negative	
	2	EXC	Resolver excitation positive	
	3	SIN	Resolver feedback SIN positive	
	4	SINLO	Resolver feedback SIN negative	
	5	COS	Resolver feedback COS positive	
	6, 7, 8	NC	Vacant internally	
	9	COSLO	Resolver feedback COS negative	
CN1	18-pin FFC interface, connecting to J4 on the control board of the AC drive			

Table 10-23 Description of indicators on MD38PG4

Indicator State	Fault of MD38PG4	Possible Cause and Solution
 D5 D6	Normal	N/A
 D5 D6	Phase-lock loop unlocked	The phase lag of the resolver is too large.
 D5 D6	Signal SIN/COS amplitude over the upper limit	D6 blinking is usually caused by interference. Ground the motor reliably and connect the ground point of the resolver card to PE of the AC drive.
 D5 D6	Signal SIN/COS amplitude too small	DB9 is not connected or incorrectly connected, or even the cable breaks. If the preceding conditions do not occur, check whether the resolver matches MD38PG4.

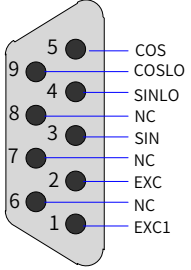
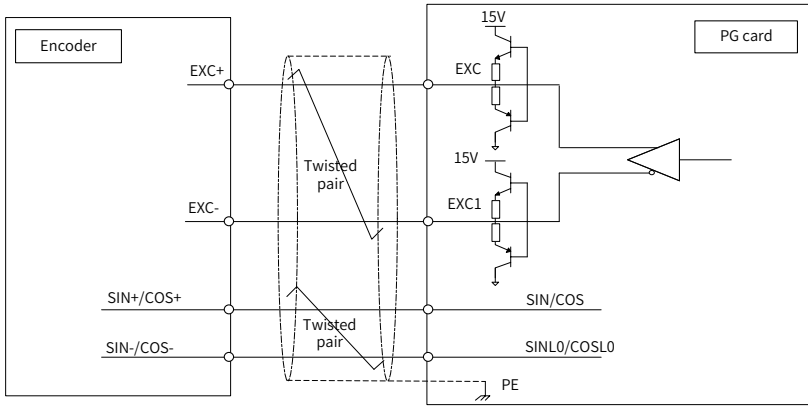

Figure 10-11 Interface circuit on MD38PG4



NOTE

- ◆ The parameters must meet the specifications of MD38PG4. Particularly, the excitation input DC resistance must be larger than $17\ \Omega$ (measurable by a multimeter). Otherwise, MD38PG4 cannot work normally.
- ◆ Do not use a resolver with more than four pole pairs because it may cause overload of MD38PG4.

10.3.4 Shield Grounding for a PG Card

If the PG card feedback speed or position is unstable while AC drive parameters are set correctly, the PG card experiences electromagnetic interference. In this case, connect the shield of the encoder signal cable to the PE point of the AC drive to restrain interference.

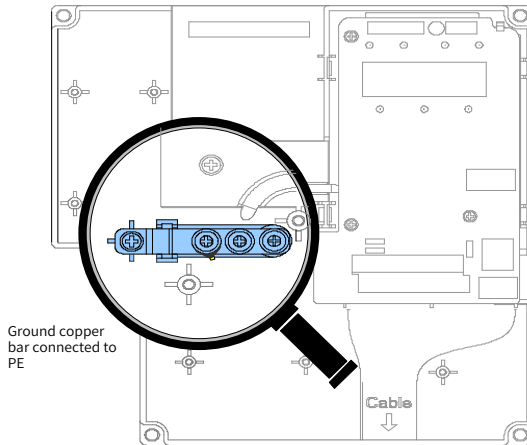

CS710 has a grounding structure. After a PG card is installed, the PE terminal of the PG card is connected automatically. When connecting an encoder, connect the shield of the signal cable to the PE terminal of the PG card to complete the shield grounding.

To install a PG card, remove the screws shown in the amplifier in the preceding figure first. Then, align mounting holes of the PG card to the three fixing pins (upper left to the amplifier) and fix the PG card with M3 x 8 screws.

10.3.5 EMC Guidance

- 1) Do not bundle signal cables (such as the encoder cable) and power cables together. Failure to comply will result in encoder interference.
- 2) Motor housing must be connected to the PE terminal of the AC drive. Meanwhile, connect the motor's ground cable to the motor housing reliably. Failure to comply will result in poor grounding effect.
- 3) Shielded twisted pairs are recommended. For differential encoders, connect twisted pairs based on differential pairs and connect the shield to the PE terminal of the AC drive.
- 4) For large equipment applications where the AC drive is far away from the motor (more than 10 m), the grounding effect deteriorates due to influence of cable inductance. In this case, the encoder shield does not need to be connected to the PE terminal of the AC drive.
- 5) Indicators on an MD38PGMD card indicate presence of interference. For details, see indicator description in preceding sections.

Appendix A Modbus Communication Protocol

CS710 series AC drives provide the RS232/RS485 interfaces and support the Modbus communication protocol. This protocol enables centralized control of AC drive using a computer or PLC. For example, you can set AC drive control commands, modify or read parameters, and read drive running status and fault information on the computer or PLC.

A.1 Data Rules

The Modbus communication protocol defines the content and format of messages transmitted during serial communication, including master polling (or broadcast) format and master coding method (parameters for the action, data transmission, and error check). The slave uses the same structure in response, including action confirmation, data returning, and error check. If an error occurs when the slave receives a message or the slave cannot complete the action required by the master, the slave returns a fault message to the master.

1) Application

The AC drive is connected to a "single-master multi-slave" PC/PLC control network with an RS232/RS485 bus.

2) Bus Structure

■ Interface type

RS232/RS485 hardware interface

■ Transmission mode

The interface performs asynchronous serial communication in half-duplex mode. In this mode, only one of the master and slave stations can send data, and the other can only receive data. During asynchronous serial communication, data is sent frame by frame.

■ Topological structure

The system consists of a single master and multiple slaves. The address range of the slaves is 0 to 247, and 0 is the broadcast address. A slave address must be unique in the network.

3) Protocol description

The Modbus communication protocol used by CS710 series AC drives is an asynchronous serial communication protocol running between master and slave devices. In a network, only one device (master) can initiate communication (query/command). The other devices (slaves) can only respond to queries or commands with required data or perform required actions. The master here is a PC, an industrial device, or a PLC, and a slave is a CS710 AC drive. The master can communicate with a single slave or broadcast messages to all slaves. When the master communicates with a single slave, the slave needs to return a message (response) to every query/command from the master. For a broadcast message sent by the master, the slaves do not need to return a response.

4) Communication Data Format

The data format defined by the Modbus protocol is as follows:

Data frames are in the RTU format, the interval between two messages must be at least 3.5-byte transmission time. The first field transmitted is the device address. The allowable

transmitted characters are hexadecimal numbers 0 ... 9, A ... F. The network devices keep monitoring the network bus, even during the silent interval. After receiving the first field (address field), each device decodes the field to determine whether itself is the destination device. Following the last transmitted character, an interval of at least 3.5-byte transmission time marks the end of the message. A new message is sent after this interval.

The entire message frame must be transmitted as a continuous stream. If there is a silent interval of longer than 1.5-byte transmission time before completion of the frame, the receiving device updates the incomplete message and assumes that the next byte is the address field of a new message. Similarly, if a new message begins earlier than 3.5-byte transmission time following a previous message, the receiving device considers the new message as a continuation of the previous message. This results in an error, as the value in the final cyclical redundancy check (CRC) field is incorrect for the combined messages.

■ RTU frame format

Field	Description
Frame header	3.5-byte transmission time
Slave address	Communication address: 0–247
Command code	03H: Read slave parameters 06H: Write slave parameters
Data field (N-1)	Parameter address, number of parameters, and values of parameters
Data field (N-2)	
...	
Data field 0	
Lower bits of the CRC CHK field	Detection value: CRC value
Higher bits of the CRC CHK field	
Frame tail	3.5-byte transmission time

■ Example of a command to read slave parameters

Read values of two contiguous parameters starting from F0.02.

Data sent from the master

Data Name	Content	Description
Slave address	01H	Set by bD.02
Command code	03H	Read instruction
Higher 8 bits of the start address	F0H	Read data from parameter F0.02
Lower 8 bits of the start address	02H	
Higher 8 bits of the number of values to read	00H	Read two values in total
Lower 8 bits of the number of values to read	02H	

Data Name	Content	Description
Lower bits of the CRC check field	CRC CHK value to be calculated	
Higher bits of the CRC check field		

Slave response data

Data Name	Content	Description
Slave address	01H	Same as the data sent from the master
Command code	03H	Same as the data sent from the master
Total number of bytes that have been read	04H	Number of values required by the master x 2
Higher bits of address F002H	00H	Value of parameter F0.02
Lower bits of address F002H	00H	
Higher bits of address F003H	00H	Value of parameter F0.03
Lower bits of address F003H	01H	
Lower bits of the CRC CHK field	CRC CHK value to be calculated	
Higher bits of the CRC CHK field		

■ Example of a command to write slave parameters

Write 1388H into F00AH of the AC drive whose slave address is 02H.

Data sent from the master

Data Name	Content	Description
Slave address	02H	Set by bD.02
Command code	06H	Write instruction
Higher bits of the address where data will be written	F0H	Write data into parameter F0.10
Lower bits of the address where data will be written	0AH	
Higher bits of the data to be written	13H	Write the value 1388H into parameter F0.10
Lower bits of the data to be written	88H	
Lower bits of the CRC CHK field	CRC CHK value to be calculated	
Higher bits of the CRC CHK field		

Slave response data: Same as the data sent from the master

5) Check Method

Cyclical Redundancy Check (CRC) is used for data verification.

In the RTU frame format, a message includes a CRC field. The CRC field verifies content of the entire message. The CRC field is two bytes long, containing a 16-bit binary value.

The CRC value is calculated and added to the message by transmission devices. Each transmission device recalculates a CRC value after receiving the message, and compares the calculated value with the CRC value in the CRC field of the message. If the two values are different, errors have occurred during transmission.

First the value 0xFFFF is saved in the register. Then a procedure is called to process the successive octet in the message and the value in the register. Only the 8-bit data in each octet is used for CRC. The start bit, stop bit and the parity bit do not apply to CRC.

During generation of the CRC value, each octet is exclusive-ORed (XOR) with the register value. Then the result is shifted toward the least significant bit (LSB), with a zero filled into the most significant bit (MSB). The LSB is extracted and examined. If the LSB is 1, the register value is XORed with a preset value. If the LSB is 0, XOR operation is not performed. This process is repeated until eight shifts have been performed. After the last (eighth) shift, the next octet is XORed with the register's current value, and the process repeats for eight more shifts as described above. The final value of the register, after all octets of the message have been applied, is the CRC value.

The CRC value is added to the message from the lower bytes to higher bytes. The simple CRC function is as follows:

```
unsigned int crc_chk_value(unsigned char *data_value,unsigned char length)
{
    unsigned int crc_value=0xFFFF;
    int i;
    while(length--)
    {
        crc_value^=*data_value++;
        for(i=0;i<8;i++)
        {
            if(crc_value&0x0001)
            {
                crc_value=(crc_value>>1)^0xa001;
            }
            else
            {
                crc_value=crc_value>>1;
            }
        }
    }
    return(crc_value);
}
```

A.2 Data Address Definition

This section describes the communication data used to control the running, status, and parameter setting of the AC drive.

Parameters can be read and written through Modbus communication. (Some parameters cannot be changed because they are only for manufacturer use or device monitoring).

1 Parameter Address Definition

The address of a parameter is identified by its group number and code, as described in the following table.

Menu	Function Parameter Group	Higher Bytes	Lower Bytes
Level-1 menu	Groups A0 to AF	A0 to AF	00 to FF
Level-2 menu	Groups b0 to bF	b0 to bF	00 to FF
	Groups U0 to U1	d0 to d1	00 to FF
	Groups E0 to EF	E0 to EF	00 to FF
Level-3 menu	Groups F0 to FF	F0 to FF	00 to FF

For example, the address of bF.12 is bF0C.



NOTE

- ◆ Some parameters cannot be modified when the AC drive is running. Some parameters cannot be modified in any status of the AC drive. In addition, pay attention to value ranges, units, and description of parameters when modifying them.

2 Target Frequency Setting (Write-only)

Parameter Address	Command Function
1000H	Frequency reference set through communication (0 to 10000, decimal)



NOTE

- ◆ The frequency reference set through communication is a percentage. The value 10000 maps to 100% of the maximum frequency (b1.02).

3 Control Command Input to the AC Drive (Write-only)

Command Address	Command Function
2000H	0001: Forward run
	0002: Reverse run
	0005: Coast to stop
	0006: Decelerate to stop
	0007: Fault reset
	0008: Quick stop

4 Read AC Drive Status (Read-only)

Command Address	Command Function
3000H	0: Stop
	Bit 0: Forward run
	Bit 1: Reverse run
	Bit 2: Faulty

5 Read Current Error Code (Read-only)

Command Address	Command Function
8000H	Displays the current error code of the AC drive. For details, see " 7 Troubleshooting ".

6 Format of Communication Error Messages (Response from the Slave)

Data Name	Content	Description
Data 1	Slave address	Communication address
Data 2	Command code + 0x80	When errors occur in communication, the slave returns an error message frame. The command code of this frame is the frame read or written address plus 0x80.
Data 3	Error code	Meanings of error codes: 01: Command code error 02: Address error 03: Data error 04: Command cannot be processed
Data 4	Lower bits of the CRC value	CRC check
Data 5	Higher bits of the CRC value	

Appendix B EMC Compliance

B.1 Definition of Terms

- 1) Electromagnetic compatibility (EMC) is the ability of electronic and electrical devices or systems to work properly in an electromagnetic environment and not to generate electromagnetic interference that influences other devices or systems. In other words, EMC requirements include two aspects:
 1. The electromagnetic interference generated by a device or system must be restricted within a certain limit.
 2. The device or system must have sufficient immunity to electromagnetic interference in the environment.
- 2) First environment: Environment that includes domestic premises. It also includes establishments directly connected without intermediate transformers to a low-voltage power supply network which supplies buildings used for domestic purposes.
- 3) Second environment: Environment that includes all establishments other than those directly connected to a low-voltage power supply network which supplies buildings used for domestic purposes.
- 4) Category C1 device: A power drive system with rated voltage below 1000 V, intended for use in the first environment.
- 5) Category C2 devices: A power drive system with rated voltage below 1000 V, which is neither a plug-in device nor a movable device. When used in the first environment, it must be installed and commissioned by professional personnel.
- 6) Category C3 device: A power drive system with rated voltage below 1000 V, intended for use in the second environment and not applicable to the first environment.
- 7) Category C4 device: A power drive system with rated voltage no less than 1000 V, or rated current no less than 400 A, or intended for use in complex systems in the second environment.

B.2 EMC Standards

B.2.1 EMC Standards

CS710 series AC drives comply with EN 61800-3: 2004 Category C2, and are applicable to both the first and second environments.

B.2.2 EMC Requirements for the Installation Environment

The integrator of the system with the AC drive installed is responsible for compliance of the system with the European EMC directive and EN 61800-3: 2004 Category C2, C3 or C4, depending on the system application environment.

Machines or facilities using this AC drive must also be CE certified and marked. The users of the machines or facilities are responsible for compliance with European directives and EN 61800-3: 2004 Category C2.



- ◆ When used in the first environment, the AC drive may generate radio interference. Besides the CE compliance described in this chapter, you must take measures to avoid radio interference if required.

B.3 Selection of Peripheral EMC Devices

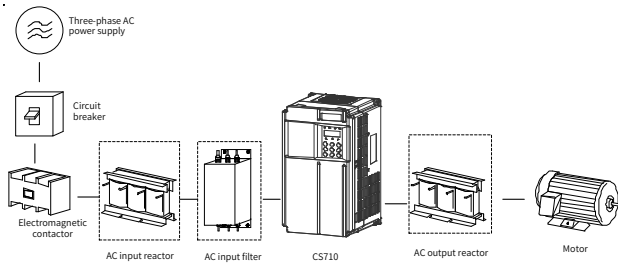

Figure B-1 Installation of peripheral EMC devices (in dashed boxes)

B.3.1 EMC Input Filter Installation on Power Input Side

An EMC input filter installed between the AC drive and the power supply can not only protect the AC drive against interference of electromagnetic noise in the surrounding environment, but also prevent interference from the AC drive on other devices. The AC drive meets the requirements of category C2 only with an EMC filter installed on the power input side. Note the following when installing an EMC filter:

- Strictly comply with the ratings when using the EMC filter. The EMC filter is category I electric apparatus, and therefore its metal housing ground must be in good contact with the metal ground of the cabinet in a large area, and have good conductive continuity. Otherwise, it will result in electric shock or poor EMC performance.
- The ground point of the EMC filter and the PE terminal of the AC drive must be connected to the same common ground. Otherwise, the EMC performance will deteriorate seriously.
- The EMC filter should be as close as possible to the power input side of the AC drive.

1 Simple EMC Filter Installation Diagram

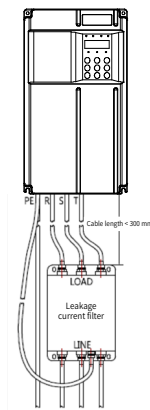

Figure B-2 Installing a simple EMC filter

2 Amorphous Core (Common Mode Filter/Zero-phase Reactor)

Installing amorphous cores on input lines R/S/T or output lines U/V/W of the AC drive can improve the EMC performance.

The following figure shows the appearance of amorphous cores.



Figure B-3 Amorphous cores

The following lists the recommended amorphous core models. Select an appropriate model based on specifications of the input and output lines.

Table B-1 Recommended amorphous core models

Amorphous Core Model	Dimensions External Diameter x Internal Diameter x Thickness (mm)
DY644020H	64 x 40 x 20
DY805020H	80 x 50 x 20
DY1207030H	120 x 70 x 30

B.3.2 AC Input Reactor Installation on the Power Input Side

An AC input reactor is an optional device used to eliminate harmonics of the input current. Install an AC input reactor when the application has strict requirements on harmonics. The following table lists the recommended AC input reactor models for CS710 series AC drives.

Table B-2 Recommended AC input reactor models

AC Drive Model	AC Input Reactor Model (Inovance)
CS710-4T0.4GB	MD-ACL-10-5-4T
CS710-4T0.7GB	MD-ACL-10-5-4T
CS710-4T1.1GB	MD-ACL-10-5-4T
CS710-4T1.5GB	MD-ACL-10-5-4T
CS710-4T2.2GB	MD-ACL-10-5-4T
CS710-4T3.0GB	MD-ACL-10-5-4T
CS710-4T3.7GB	MD-ACL-15-3-4T
CS710-4T5.5GB	MD-ACL-15-3-4T
CS710-4T7.5GB	MD-ACL-40-1.45-4T
CS710-4T11GB	MD-ACL-40-1.45-4T
CS710-4T15GB	MD-ACL-50-1.2-4T
CS710-4T18.5GB	MD-ACL-50-0.28-4T-2%

AC Drive Model	AC Input Reactor Model (Inovance)
CS710-4T22GB	MD-ACL-60-0.24-4T-2%
CS710-4T30GB	MD-ACL-90-0.16-4T-2%
CS710-4T37GB	MD-ACL-90-0.16-4T-2%
CS710-4T45GB	MD-ACL-120-0.12-4T-2%
CS710-4T55GB	MD-ACL-150-0.095-4T-2%
CS710-4T75GB	MD-ACL-200-0.07-4T-2%
CS710-4T90G	MD-ACL-250-0.056-4T-2%
CS710-4T110G	MD-ACL-250-0.056-4T-2%
CS710-4T132G	MD-ACL-330-0.042-4T-2%
CS710-4T160G	MD-ACL-330-0.042-4T-2%
CS710-4T200G(-L)	MD-ACL-490-0.028-4T-2%
CS710-4T220G(-L)	MD-ACL-490-0.028-4T-2%
CS710-4T250G(-L)	MD-ACL-490-0.028-4T-2%
CS710-4T280G(-L)	MD-ACL-660-0.021-4T-2%
CS710-4T315G(-L)	MD-ACL-660-0.021-4T-2%
CS710-4T355G(-L)	MD-ACL-800-0.017-4T-2%
CS710-4T400G(-L)	MD-ACL-800-0.017-4T-2%

B.3.3 AC Output Reactor Installation on Output Side

Determine whether to install an AC output reactor on the output side of the AC drive based on actual situations. The cable connecting the AC drive and motor should not be too long, as a long cable has high distributed capacitance, which in turn produces high leakage current.

If the output cable is too long, install an AC output reactor. If the cable length is longer than or equal to the limit listed in Table B-3, install an AC output reactor close to the AC drive.

Table B-3 Output cable lengths that require the use of an AC output reactor

AC Drive Power (kW)	Rated Voltage (V)	Maximum cable length without AC output reactor
4	200-500	50
5.5	200-500	70
7.5	200-500	100
11	200-500	110
15	200-500	125
18.5	200-500	135
22	200-500	150
≥ 30	280-690	150

The following table lists recommended AC output reactor models for CS710 series AC drives.

Table B-4 Recommended AC output reactor models

AC Drive Model	AC Output Reactor Model (Inovance)
CS710-4T0.4GB	MD-OCL-5-1.4-4T-1%
CS710-4T0.7GB	MD-OCL-5-1.4-4T-1%
CS710-4T1.1GB	MD-OCL-5-1.4-4T-1%
CS710-4T1.5GB	MD-OCL-5-1.4-4T-1%
CS710-4T2.2GB	MD-OCL-7-1.0-4T-1%
CS710-4T3.0GB	MD-OCL-10-0.7-4T-1%
CS710-4T3.7GB	MD-OCL-10-0.7-4T-1%
CS710-4T5.5GB	MD-OCL-15-0.47-4T-1%
CS710-4T7.5GB	MD-OCL-20-0.35-4T-1%
CS710-4T11GB	MD-OCL-30-0.23-4T-1%
CS710-4T15GB	MD-OCL-40-0.18-4T-1%
CS710-4T18.5GB	MD-OCL-50-0.14-4T-1%
CS710-4T22GB	MD-OCL-60-0.12-4T-1%
CS710-4T30GB	MD-OCL-80-0.087-4T-1%
CS710-4T37GB	MD-OCL-90-0.078-4T-1%
CS710-4T45GB	MD-OCL-120-0.058-4T-1%
CS710-4T55GB	MD-OCL-120-0.058-4T-1%
CS710-4T75GB	MD-OCL-200-0.035-4T-1%
CS710-4T90G	MD-OCL-250-0.028-4T-1%
CS710-4T110G	MD-OCL-250-0.028-4T-1%
CS710-4T132G	MD-OCL-330-0.021-4T-1%
CS710-4T160G	MD-OCL-330-0.021-4T-1%
CS710-4T200G(-L)	MD-OCL-490-0.014-4T-1%
CS710-4T220G(-L)	MD-OCL-490-0.014-4T-1%
CS710-4T250G(-L)	MD-OCL-490-0.014-4T-1%
CS710-4T280G(-L)	MD-OCL-660-0.011-4T-1%
CS710-4T315G(-L)	MD-OCL-660-0.011-4T-1%
CS710-4T355G(-L)	MD-OCL-800-0.0087-4T-1%
CS710-4T400G(-L)	MD-OCL-800-0.0087-4T-1%

B.4 Shielded Cables

B.4.1 Requirements for Shielded Cables

To meet EMC requirements of CE marking, the AC drive must use shielded cables. Shielded cables are classified into three-conductor and four-conductor cables. If the shield of a three-conductor cable does not have sufficient conductivity, add an independent PE cable, or use a four-conductor cable, of which one conductor is a PE wire, as shown in the following figure.

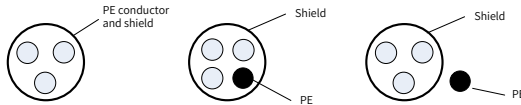

Figure B-4 Shielded cables

To suppress emission and conduction of radio interference signals, the shield layer of a shielded cable is made by coaxial copper braid. The braided density of the copper braid should be greater than 90% to enhance the shielding efficiency and conductivity. The following figure shows the shield layer of a shielded cable.

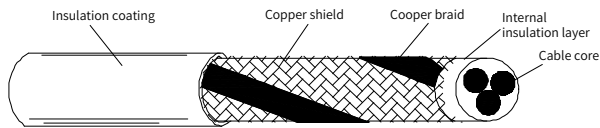

Figure B-5 Shield layer of a shielded cable

The following figure shows grounding of a shielded cable.

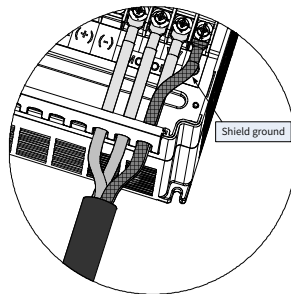

Figure B-6 Grounding of a shielded cable

Note the following for use of shielded cables:

- Symmetrical shielded cables are recommended. Four-conductor cables can also be used as input cables.
- The motor cable and PE shielded conducting wire (twisted shielded) should be as short as possible to reduce electromagnetic radiation and external stray current and capacitive current of the cable. If a motor cable is over 100 meters long, install an output filter or reactor.

- It is recommended that all control cables be shielded.
- The output power cable of the AC drive should be a shielded cable, with the shield reliably grounded. For lead wires in exposure to interference, shielded twisted pair control cables should be used, with the shield reliably grounded.

B.4.2 Cabling Requirements

- 1) The motor cables must be far away from other cables. Motor cables of multiple AC drives can be routed in parallel.
- 2) It is recommended that the motor cables, power input cables and control cables be routed in different cable troughs. To prevent electromagnetic interference caused by rapid changes of the AC drive's output voltage, do not route motor cables in parallel to other cables over a long distance.
- 3) If control cables must run across power cables, make sure they are arranged at an angle of close to 90°. Do not put other cables through the AC drive.
- 4) The power input and output cables of the AC drive and low-voltage signal cables (such as control cables) should be routed perpendicularly (if possible) rather than in parallel.
- 5) Cable troughs must be connected properly and reliably grounded. Aluminium cable troughs can be used to improve electric potential.
- 6) The filter, AC drive, and motor should be connected to the system (machinery or appliance) properly, with protective coating at the installation part and conductive metal in full contact.

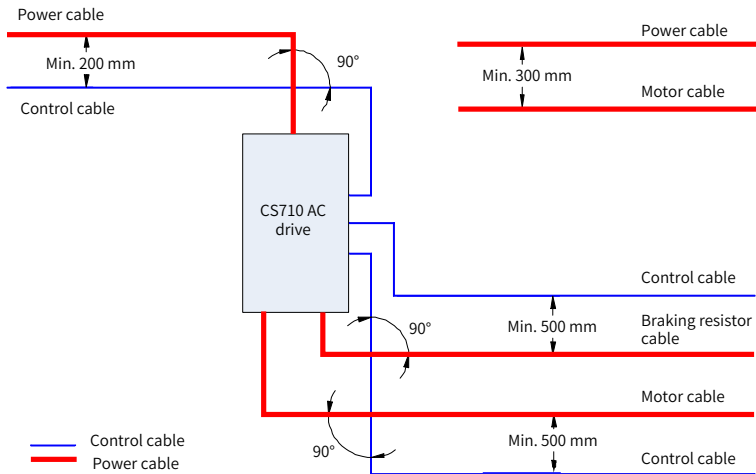

Figure B-7 Cabling diagram

B.5 Leakage Current Requirements

- 1) Each AC drive produces more than 100 mA leakage current. Therefore, the current sensitivity of the leakage circuit breaker must be above 100 mA.
- 2) High-frequency pulse interference may cause the circuit breaker to malfunction, and therefore the leakage circuit breaker must have the high-frequency filtering function.
- 3) If multiple AC drives are required, each AC drive must be equipped with a circuit breaker.
- 4) The following factors influence the leakage current:
 - Capacity of the AC drive
 - Carrier frequency
 - Type and length of the motor cable
 - EMI filter
- 5) When the leakage current causes the circuit breaker to trip, you should:
 - Increase the current sensitivity value of the circuit breaker.
 - Replace the circuit breaker with another one supporting high-frequency suppression.
 - Lower the carrier frequency.
 - Shorten the length of the output cable.
 - Install a current leakage restraining device.
 - An EMC filter can restrain leakage current. For details on how to select an EMC filter, see "[B.3.1 EMC Input Filter Installation on Power Input Side](#)".
- 6) EMC and VDR jumper screws
 - An AC drive has the integrated safety capacitor set (EMC) and varistor (VDR), which are connected by default. If the leakage circuit breaker trips when the AC drive is powered on, remove the EMC jumper screw (described as EMC jumper screw in the following figure) to disconnect the safety capacitor set.

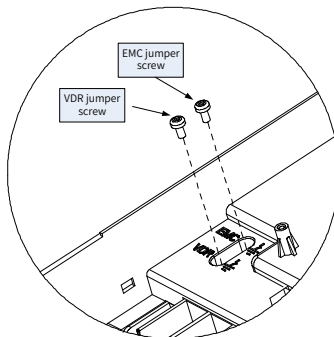

Figure B-8 VDR and EMC jumper screws

B.6 Solutions to EMC Interference

An AC drive generates strong interference. Although EMC measures are taken, interference may still exist due to improper cabling or grounding during use. When the AC drive interferes with other devices, take the following measures.

Table B-5 Common EMC interference issues and solutions

Interference Type	Solution
ELCB tripping	<ul style="list-style-type: none"> ◆ Connect the motor housing to the PE terminal of the AC drive. ◆ Connect the PE terminal of the AC drive to the PE of the mains power supply. ◆ Add a safety capacitor to the power input cable. ◆ Add magnetic rings to the input AC drive cable.
Interference from a running AC drive	<ul style="list-style-type: none"> ◆ Connect the motor housing to the PE terminal of the AC drive. ◆ Connect the PE terminal of the AC drive to the PE of the mains power supply. ◆ Add a safety capacitor to the power input cable and wind the cable with magnetic rings. ◆ Add a safety capacitor to the interfered signal port or wind the signal cable with magnetic rings. ◆ Connect the equipment to the common ground.
Communication interference	<ul style="list-style-type: none"> ◆ Connect the motor housing to the PE terminal of the AC drive. ◆ Connect the PE terminal of the AC drive to the PE of the mains power supply. ◆ Add a safety capacitor to the power input cable and wind the cable with magnetic rings. ◆ Add a termination resistor at the communication cable source and the load side. ◆ Add a common grounding cable besides the communication cable. ◆ Use a shielded cable as the communication cable and connect the cable shield to the common grounding point.
I/O interference	<ul style="list-style-type: none"> ◆ Enlarge the capacitance at low-speed DI terminals. A maximum capacitance of 0.1 uF is recommended. ◆ Enlarge the capacitance at AI terminals. A maximum capacitance of 0.22 uF is recommended.

INOVANCE Warranty Agreement

- 1) Inovance provides an 18-month free warranty to the equipment itself from the date of manufacturing for the failure or damage under normal use conditions.
- 2) Within the warranty period, maintenance will be charged for the damage caused by the following reasons:
 - a. Improper use or repair/modification without prior permission
 - b. Fire, flood, abnormal voltage, natural disasters and secondary disasters
 - c. Hardware damage caused by dropping or transportation after procurement
 - d. Operations not following the user instructions
 - e. Damage out of the equipment (for example, external device factors)
- 3) The maintenance fee is charged according to the latest Maintenance Price List of Inovance.
- 4) If there is any problem during the service, contact Inovance's agent or Inovance directly.
- 5) Inovance reserves the rights for explanation of this agreement.

Suzhou Inovance Technology Co., Ltd.

Address: No.16, Youxiang Road, Yuexi Town, Wuzhong District, Suzhou 215104, P.R. China

Website: <http://www.inovance.com>

Shenzhen Inovance Technology Co., Ltd.

Add.: Building E, Hongwei Industry Park, Liuxian Road, Baocheng No. 70 Zone, Bao'an District, Shenzhen

Tel: +86-755-2979 9595

Fax: +86-755-2961 9897

<http://www.inovance.com>

Suzhou Inovance Technology Co., Ltd.

Add.: No. 16 Youxiang Road, Yuexi Town, Wuzhong District, Suzhou 215104, P.R. China

Tel: +86-512-6637 6666

Fax: +86-512-6285 6720

<http://www.inovance.com>



19010423A05