

Right choice for ultimate yield

LSIS strives to maximize customers' profit in gratitude of choosing us for your partner.

Programmable Logic Controller

Rnet I/F Module

XGT Series

User's Manual

XGL-RMEA



Safety Instructions

- Read this manual carefully before installing, wiring, operating, servicing or inspecting this equipment.
- Keep this manual within easy reach for quick reference.

LSIS

<http://eng.lsis.biz>

Safety Instructions

Before using the product ...

For your safety and effective operation, please read the safety instructions thoroughly before using the product.

- ▶ Safety Instructions should always be observed in order to prevent accident or risk by using the product properly and safely.
- ▶ Precautionary measures can be categorized as “Warning” and “Caution”, and each of the meanings is as follows.





This symbol indicates the possibility of serious injury or death if some applicable instruction is violated



This symbol indicates the possibility of severe or slight injury, and damages in products if some applicable instruction is violated

Moreover, even classified events under its caution category may develop into serious accidents depending on situations. Therefore we strongly advise users to observe all precautions in a proper way just like warnings.

- ▶ The marks displayed on the product and in the user’s manual have the following meanings.
 -  Be careful! Danger may be expected.
 -  Be careful! Electric shock may occur.

After reading this user’s manual, it should be stored in a place that is visible to product users.

Safety Instructions

Safety Instructions for design process

Warning

- ▶ **Please install a protection circuit on the exterior of PLC so that the whole system may operate safely regardless of failures from external power or PLC.** Any abnormal output or operation from PLC may cause serious problems to safety in whole system.
 - Install protection units on the exterior of PLC like an interlock circuit that deals with opposite operations such as emergency stop, protection circuit, and forward/reverse rotation or install an interlock circuit that deals with high/low limit under its position controls.
 - If any system error (watch-dog timer error, module installation error, etc.) is detected during CPU operation in PLC, all output signals are designed to be turned off and stopped for safety. However, there are cases when output signals remain active due to device failures in Relay and TR which can't be detected. Thus, you are recommended to install an addition circuit to monitor the output status for those critical outputs which may cause significant problems.

- ▶ **Never overload more than rated current of output module nor allow to have a short circuit.** Over current for a long period time may cause a fire .

- ▶ **Never let the external power of the output circuit to be on earlier than PLC power,** which may cause accidents from abnormal output or operation.

- ▶ **Please install interlock circuits in the sequence program for safe operations in the system when exchange data with PLC or modify operation modes using a computer or other external equipments**
Read specific instructions thoroughly when conducting control operations with PLC.

Safety Instructions

Safety Instructions for design process

Caution

- ▶ **I/O signal or communication line shall be wired at least 100mm away from a high-voltage cable or power line.** Fail to follow this instruction may cause malfunctions from noise

Safety Instructions on installation process

Caution

- ▶ **Use PLC only in the environment specified in PLC manual or general standard of data sheet.** If not, electric shock, fire, abnormal operation of the product may be caused.
- ▶ **Before install or remove the module, be sure PLC power is off.** If not, electric shock or damage on the product may be caused.
- ▶ **Be sure that every module is securely attached after adding a module or an extension connector.** If the product is installed loosely or incorrectly, abnormal operation, error or dropping may be caused. In addition, contact failures under poor cable installation will be causing malfunctions as well.
- ▶ **Be sure that screws get tighten securely under vibrating environments.** Fail to do so will put the product under direct vibrations which will cause electric shock, fire and abnormal operation.
- ▶ **Do not come in contact with conducting parts in each module,** which may cause electric shock, malfunctions or abnormal operation.

Safety Instructions

Safety Instructions for wiring process

Warning

- ▶ **Prior to wiring works, make sure that every power is turned off.** If not, electric shock or damage on the product may be caused.
- ▶ **After wiring process is done, make sure that terminal covers are installed properly before its use.** Fail to install the cover may cause electric shocks.

Caution

- ▶ **Check rated voltages and terminal arrangements in each product prior to its wiring process.** Applying incorrect voltages other than rated voltages and misarrangement among terminals may cause fire or malfunctions.
- ▶ **Secure terminal screws tightly applying with specified torque.** If the screws get loose, short circuit, fire or abnormal operation may be caused. Securing screws too tightly will cause damages to the module or malfunctions, short circuit, and dropping.
- *
 - ▶ **Be sure to earth to the ground using Class 3 wires for FG terminals which is exclusively used for PLC.** If the terminals not grounded correctly, abnormal operation or electric shock may be caused.
 - ▶ **Don't let any foreign materials such as wiring waste inside the module while wiring,** which may cause fire, damage on the product or abnormal operation.
 - ▶ **Make sure that pressed terminals get tighten following the specified torque. External connector type shall be pressed or soldered using proper equipments.**

Safety Instructions

Safety Instructions for test-operation and maintenance

Warning

- ▶ **Don't touch the terminal when powered.** Electric shock or abnormal operation may occur.
- ▶ **Prior to cleaning or tightening the terminal screws, let all the external power off including PLC power.** If not, electric shock or abnormal operation may occur.
- ▶ **Don't let the battery recharged, disassembled, heated, short or soldered.** Heat, explosion or ignition may cause injuries or fire.

Caution

- ▶ **Do not make modifications or disassemble each module.** Fire, electric shock or abnormal operation may occur.
- ▶ **Prior to installing or disassembling the module, let all the external power off including PLC power.** If not, electric shock or abnormal operation may occur.
- ▶ **Keep any wireless equipment such as walkie-talkie or cell phones at least 30cm away from PLC.** If not, abnormal operation may be caused.
- ▶ **When making a modification on programs or using run to modify functions under PLC operations, read and comprehend all contents in the manual fully.** Mismanagement will cause damages to products and accidents.
- ▶ **Avoid any physical impact to the battery and prevent it from dropping as well.** Damages to battery may cause leakage from its fluid. When battery was dropped or exposed under strong impact, never reuse the battery again. Moreover skilled workers are needed when exchanging batteries.

Safety Instructions

Safety Instructions for waste disposal

 **Caution**

- ▶ **Product or battery waste shall be processed as industrial waste.**
The waste may discharge toxic materials or explode itself.

Revision History

Version	Data	Remark	Page
V1.0	'05.03	First Edition.	
V1.1	'05.05	Description of function added (Page: A-1).	A-1
V1.2	'06.06	Terminologies are edited.	
V2.0	'07.03	1. Added separate reset function 2. Version up about XG-PD software	
V2.1	'09.06	Content added and revision	1-1~1-4, 5-1
V2.2	'11.05	How to enable link through flag added	CH 5.2

※ The number of User's manual is indicated right part of the back cover.

© LSIS Co., Ltd 2005 All Rights Reserved.

About User's Manual

About User's Manual

Congratulations on purchasing PLC of LSIS Co.,Ltd.

Before use, make sure to carefully read and understand the User's Manual about the functions, performances, installation and programming of the product you purchased in order for correct use and importantly, let the end user and maintenance administrator to be provided with the User's Manual.

The Use's Manual describes the product. If necessary, you may refer to the following description and order accordingly. In addition, you may connect our website(<http://eng.lsis.biz/>) and download the information as a PDF file.

Relevant User's Manuals

Title	Description	No. of User's Manual
XGK-CPUA/CPUE/CPUH/CPUS User's Manual	It describes specifications, system structure and EMC spec. correspondence of CPU module, power module, base, I/O module and increase cable	10310000508
XG5000 User's Manual	It describes how to use XG5000 software especially about online functions such as programming, printing, monitoring and debugging by using XGK series products.	10310000512
XGK Series Instructions & Programming	It is the user's manual for programming to explain how to use commands that are used PLC system with XGK CPU.	10310000510

© Table of Contents ©

Chapter 1 Introduction ----- 1-1 ~ 1-4

1.1 Introduction -----	1-1
1.2 Characteristics -----	1-2
1.3 Product Information -----	1-3

Chapter 2 Specifications ----- 2-1 ~ 2-5

2.1 General Specifications -----	2-1
2.2 Performance Specifications -----	2-2
2.3 Structure and Characteristics -----	2-3
2.4 Terminal Resistance -----	2-5

Chapter 3 Installation and Test Operation of the Product ----- 3-1 ~ 3-2

3.1 Precautions for Installation -----	3-1
3.1.1 Precautions for installation -----	3-1
3.2 From Setting to Operation -----	3-2

Chapter 4 System Configuration ----- 4-1 ~ 4-3

4.1 System Configuration of Network-----	4-1
4.1.1 XGL-RMEA + Smart I/O -----	4-1
4.1.2 XGL-RMEA + Rack type of remote -----	4-1
4.1.3 XGL-RMEA + PMU -----	4-2
4.1.4 XGL-RMEA + Composite system -----	4-3

Chapter 5 High-speed Link Setting ----- 5-1 ~ 5-17

5.1 Introduction -----	5-1
5.2 How to use XG-PD -----	5-2
5.3 High-speed link editing -----	5-7
5.4 Read and write of High-speed Link -----	5-12
5.5 System diagnosis -----	5-13
5.6 High-speed link information -----	5-16

Chapter 6 Remote Communication Control ----- 6-1 ~ 6-4

6.1 Introduction ----- 6-1
6.2 Remote connection example of XG-5000/XG-PD ----- 6-2
 6.2.1 Remote 1 connection ----- 6-2

Chapter 7 Program Example ----- 7-1 ~ 7-10

7.1 XG5000 program ----- 7-1

Appendix ----- A-1 ~ A-4

A.1 Terminology ----- A-1
A.2 List of HS link flags ----- A-2
A.3 External Dimensions ----- A-4

Chapter 1 Overview

1.1 Introduction

This manual of Rnet I/F module is prepared to describe XGT series of dedicated remote net (**hereinafter referred to as Rnet I/F module**). XGT Rnet I/F module is composed of data link layer and physical layer in OSI 7 layers. Rnet system controls I/O data from the sensor of field level and manages the data conveniently for monitoring, troubleshooting and maintenance through LS HMI of PMU unit. Rnet I/F module supports a speed of 1Mbps, up to 64 stations (including master) and provides convenience of data Tx/Rx for users by means of XG-PD parameters setting, through LS dedicated network. Generally, electric cable is used for Rnet system configuration, however, electric/optic repeater is provided here for the purpose of remote application and reliance improvement for users to configure the system expansively. In addition, XGT Rnet I/F module can configure GM/MK series of Rack type remote, which can be usefully applied to the location where lots of points are required.

To create a program, refer to the following manuals together.

- XG5000 user manual
- XGK instruction
- XGK user manual
- XGI/XGR instruction
- XGI/XGR user manual

The current user's manual of XGT RAPIEnet I/F Module is prepared, based on the following versions.

- XGT PLC XG5000 Programming Tool: V2.0 or above
- XG-PD: V2.0 or above
- XGT Rnet I/F Module O/S: V1.1 or above

1.2 Characteristics

XGT Rnet I/F module has the following characteristics;

Rnet I/F module :

- ▶ LS dedicated network
- ▶ Convenient with High-speed link parameters setting is available
- ▶ Electric/optic repeater option is provided
- ▶ Remote stage 1 connection service is available through G3L-RREA
- ▶ Program monitoring/editing is available with connecting to CPU through G0L-GWRA
- ▶ Reduced wiring, easy installation
- ▶ Up to 12 units can be installed on 1 basic base
- ▶ Various system configurations are available through basic parameters changes
- ▶ Smart I/O + Rnet system configuration is available

Chapter 1 Overview

1.3 Product information

[Table 1.3.1] Family products of XGT Rnet I/F modules

Classification	Connection cable	Model	Product code	Description	Remarks	
Master module	Twisted pair (electric)	XGL-RMEA	47200006	-	XGT Rnet master module	
Slave module	Twisted pair (electric)	G3L-RREA	46300143	Installed on GM3/K1000S CPU position	Rack type remote system	
		G4L-RREA	46310159	Installed on GM4/K300S CPU position		
		G6L-RREA	46640104	Installed on GM6/K200S CPU position		
		GRL-D22A	47060001	DC input 16 points	Smart I/O Rnet series - Fixed terminal block - 9-pin communication connector	
		GRL-D24A	47060002	DC input 32 points		
		GRL-TR2A	47060003	TR output 16 points (0.1A, Sink)		
		GRL-TR4A	47060004	TR output 32 points (0.1A, Sink)		
		GRL-RY2A	47060005	Relay output 16 points		
		GRL-DT4A	47060006	DC input 16 points/ TR output 16 points		
		GRL-D22A(N)	4706000133	DC input 16 points		Smart I/O Rnet series - Fixed terminal block - 5-pin communication connector
		GRL-D24A(N)	4706000233	DC input 32 points		
		GRL-TR2A(N)	4706000333	TR output 16 points (0.1A, Sink)		
		GRL-TR4A(N)	4706000433	TR output 32 points (0.1A, Sink)		
		GRL-RY2A(N)	4706000533	Relay output 16 points		
		GRL-DT4A(N)	4706000633	DC input 16 points/ TR output 16 points		
				XRL-BSSA	4706158	Digital input/output 512 point
Repeater		G0L-FREB	46290016	For cable extension (750m)	Possible Solely	
Signal converter		G0L-FOEA	46290004	For optic/electric signal conversion	Possible Solely	
Optic signal distributor (Active coupler)		G0L-FABA	46290001	Base module	-	
		G0L-FAPA	46290003	AC power module	-	
		G0L-FACA	46290002	Optic interface module	-	
		G0L-FADA	46290009	Dummy module	-	
Loader I/F module		G0L-GWRA	47060038	For GMWIN/KGLWIN/XG5000 connection	One for one system	

1.3.2 The number of equip-able modules per CPU

The maximum installation number of modules is 12 regardless of base type (basic base and extension). For maximum performance of communication module, it is recommended to equip the module on basic base. The following table indicates available service type per each CPU. After due consideration of the number of communication modules, apply to the system configuration.

Classification	XGK					XGI	XGR	
	CPUH	CPUU	CPUA	CPUS	CPUE	CPUU	CPUH/T	CPUH/F
No. of module using High Speed Link (Max.)	12							
No. of module using P2P (Max.)	P2P is not used							
No. of module using dedicated service (Max.)	Dedicated service is not used							

Notes

- 1) Optic signal distributor is called as Active Coupler.
- 2) As 8 G0L-FACAs can be installed on the optic signal distributor, 3 G0L-FADAs (dummy module) are needed more if 5 G0L-FACAs have been installed.

Chapter 2 Specifications

Chapter 2 Specifications

2.1 General Specifications

General specifications of XGT series are as shown in Table 2.1.

No.	Item	Specification	Related specifications			
1	Operating temperature	0°C ~ +55°C				
2	Storage temperature	-25°C ~ +70°C				
3	Operating humidity	5 ~ 95%RH, Non-condensing				
4	Storage humidity	5 ~ 95%RH, Non-condensing				
5	Vibration	For discontinuous vibration		IEC 61131-2		
		Frequency	Acceleration		Amplitude	Number
		10 ≤ f < 57 Hz	-		0.075 mm	
		57 ≤ f ≤ 150 Hz	9.8 m/s ² (1G)		-	
		For continuous vibration			Each 10 times in X, Y, Z directions	
		Frequency	Acceleration			Amplitude
		10 ≤ f < 57 Hz	-			0.035 mm
		57 ≤ f ≤ 150 Hz	4.9 m/s ² (0.5G)	-		
6	Shock	* Maximum impact acceleration: 147 m/s ² (15G) * Authorized time: 11 m/s * Pulse wave : Signal half-wave pulse (Each 3 times in X,Y,Z directions)		IEC 61131-2		
7	Noise Immunity	Square wave impulse noise		±1,500V	Test specification LSIS	
		Electrostatic discharging		Voltage: 4kV (contact discharging)	IEC 61131-2, IEC 61000-4-2	
		Radiated electromagnetic		27 ~ 500 MHz, 10 V/m	IEC 61131-2, IEC 61000-4-3	
		Fast Transient /burst noise	Class	Power module	Digital/Analog I/O communication interface	IEC 61131-2, IEC 61000-4-4
	Voltage	2 kV	1 kV			
8	Ambient conditions	No corrosive gas or dust				
9	Operating height	2,000 m or less				
10	Pollution degree	2 or less				
11	Cooling type	Natural air cooling				

[Table 2.1] General Specifications

Notes

- 1) IEC (International Electrotechnical Commission)
: An international nongovernmental organization which promotes internationally cooperated standardization in electric/electronic fields, publishes international standards and manages applicable estimation system related with.
- 2) Pollution degree
: An index indicating pollution degree of the operating environment which decides insulation performance of the devices. For instance, Pollution degree 2 indicates the state generally that only non-conductive pollution occurs. However, this state contains temporary conduction due to dew produced.

Chapter 2 Specifications

2.2 Performance Specifications

Specifications for system configuration of Rnet I/F module are as described below.

Please refer to the table below for system configuration.

Item		Specifications
Transmission Speed		1Mbps (Rnet I/F modules common)
Max. Tx distance	Segment	Max. 750m
	Network	Maximum 750m + 6 repeaters(750m*6) = 5.25km - Repeater extension distance : 750m
Connection Cable		Twisted pair shielded cable - LIREV-AMESB 1Px22AWG (7/0.254):LS Cables
Maximum stations connected	Network	Master station 1[station no:0(fixed)] + Slave station 63[station no:1~63] = Max. 64 stations - Only 1 master is available in the network.
	Segment	Master station 1[station no:0(fixed)] + Slave station 31[station no:1~63] = Max. 32 stations (In case of 32 stations, you have to use repeater.) - Only 1 master is available in the network.
Diagnostic function		XG-PD : High Speed Link Monitoring
System characteristic		Available detachment and attachment of slave module during communication
Terminal resistance		110(5%,1/2W)
Master/Slave operation		Only available as Master
XG-PD (HS Link)	Data Processing unit	Byte
	Tx/Rx cycle	Selection among 20ms, 50ms, 100ms, 200ms, 500ms, 1s, 5s, 10s(default :20ms)
	Max. Communication points.	3,780Words(slave 63stations * 60words/station)
	Max. Block number	63(setting range : 0~62)
	Max. points by Block	120 Byte(60words)
	Max. Tx. Block number	8 Blocks
	HS Link number	Max. 12
Specification	Max. module mounted	12 modules(Main Base + Extension Base)
	Internal current consumption(mA)	410
	Weight(g)	115

2.3 Structure and Characteristics

1) LED display

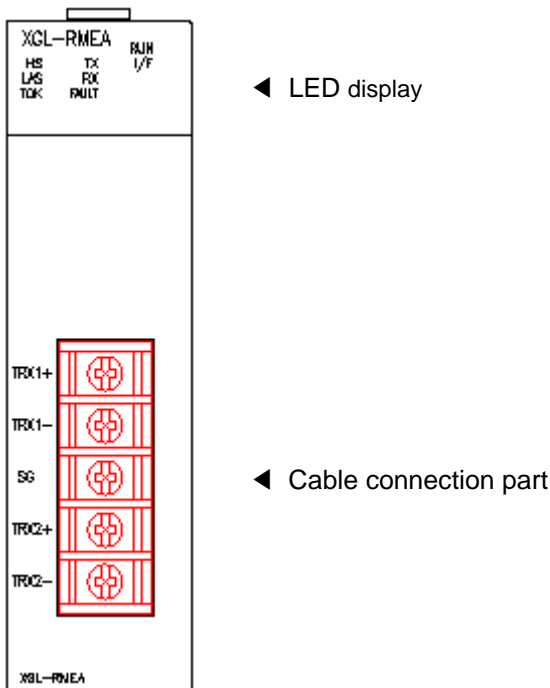

SILK display	LED status	LED details
RUN	On	Normal
	Off	Serious defect, Contact Customer Service Center
I/F	Blinks	Normal
	On/Off	Serious defect, Contact Customer Service Center
HS	On	During High-speed link communication service
	Off	Suspend High-speed link communication service
	Blinks	Check slave modules (when configuration for GRL-TR4A, it occurs automatically)
LAS	On	Normal communication
	Blinks	Master module, Contact Customer Service Center
TX	On	Normal
	Off	Check High-speed link parameters
RX	On	Normal
	Off	Check High-speed link parameters
TOK	On	Normal
	Off	Master module, Contact Customer Service Center
FAULT	On/Blinks	Check cable connection and wiring
	Off	Normal

Chapter 2 Specifications

2) Cable connection part

(1) Cable specifications (LS cables)

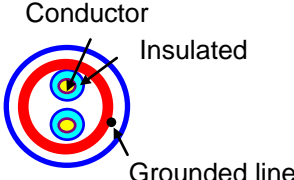
Designations	LIREV-AMESB 2 * 0.64mm 22AWG	Structure
Manufacturer	LS Cables	
Cable type	Shielded twisted pair	
Conductor resistance	59Ω/km (normal temperature)	
Voltage resistance (DC)	500 V/Min (normal temperature)	
Insulated resistance	1,000 MΩ/km or more	
Capacitance	45 pF/m or less (1 kHz)	
Characteristic impedance	120±12Ω (10 MHz)	
Number of cores	2 Core	

(2) Cable connection

a) Connection with Smart I/O D-sub

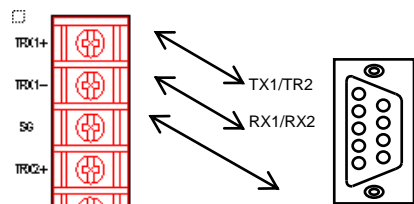
XGL-RMEA	Smart I/O D-Sub 9pin	Wiring
TRX1+/TRX2+	TX1/TX2	
TRX1-/TRX2-	RX1/RX2	
SG	9Pin Shield	

b) Smart I/O 5-pin

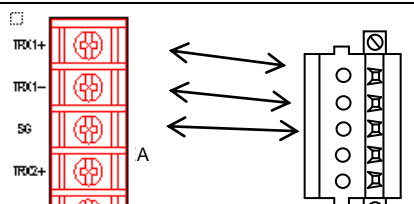
XGL-RMEA	Smart I/O 5pin	Wiring
TRX1+/TRX2+	Red (TRX+)	
TRX1-/TRX2-	White (TRX-)	
SG	Colorless (SG)	

2.4 Terminal resistance

Be sure to install the terminal resistance on the both ends of the line. Connect Smart I/O Rnet with TX1 and RX1, and Rnet I/F module with TRX2+ and TRX2-.

- Resistance value: 110Ω , $1/2W$, allowance 5%
- Contact between connector case and terminal resistance is not allowed.

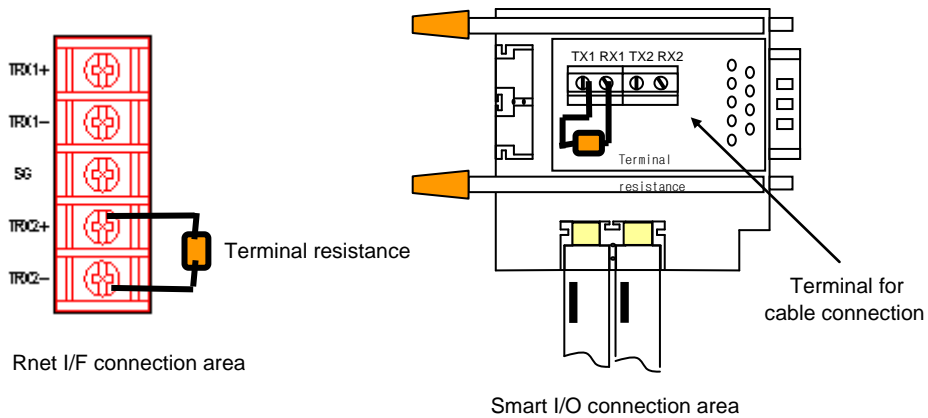

[Fig. 2.4.1] Connection of terminal resistance

Chapter 3 Installation and Test Operation of the Product

3.1 Precautions for Installation

3.1.1 Precautions for installation

For system configuration through Rnet I/F module, carefully make sure of the following items prior to installation.

- 1) Check the basic factors for necessity of configuring the system and select an appropriate communication module.
- 2) Select the cable to be used for this communication module (surely use the standard cable).
- 3) Before the communication module is installed, check with any foreign material on the base connector the module will be installed on and any damage on the connector pin of the module.
- 4) For installation of the module, exactly insert the protuberant part at the bottom of the module with the communication cable disconnected into the base groove and then apply enough strength until its top is locked up with the locking device of the base. If the lock is not applied, it may cause an error on the interface with CPU.

3.2 From Setting to Operation

The sequence of the product from installation to operation will be described below. After the product installation is complete, install and configure the system to be operated as specified in the following sequence.

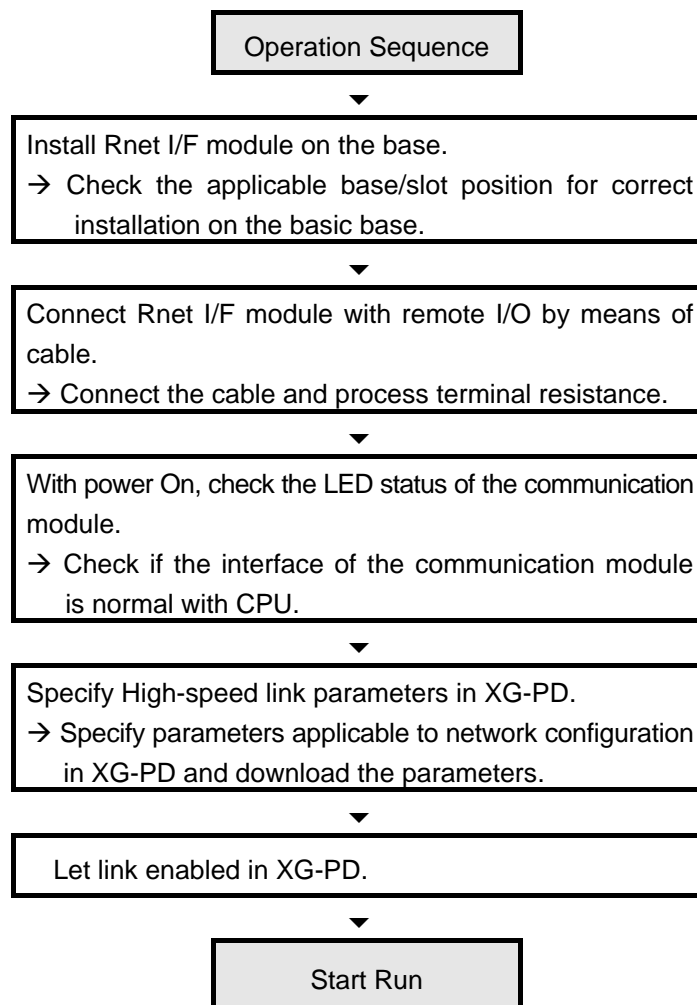

Notes

- 1) The station number of the master module is set to 0.
- 2) The station number of the remote I/O should not be set to 0.

Chapter 4 System Configuration

4.1 System Configuration of Network

4.1.1 XGL-RMEA + Smart I/O

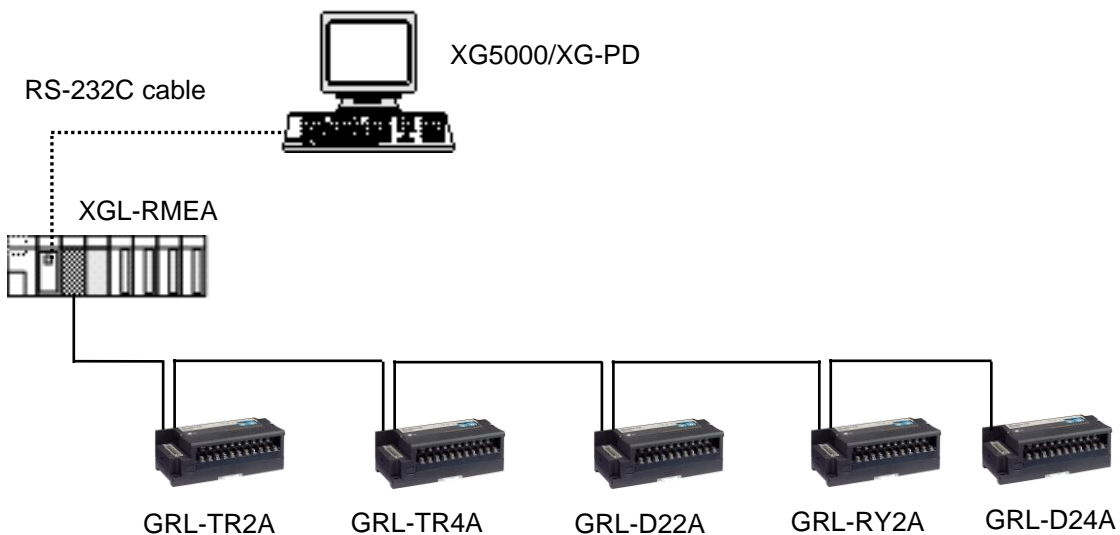

[Fig. 4.1.1] System configuration of Smart I/O

4.1.2 XGL-RMEA + Rack type of remote

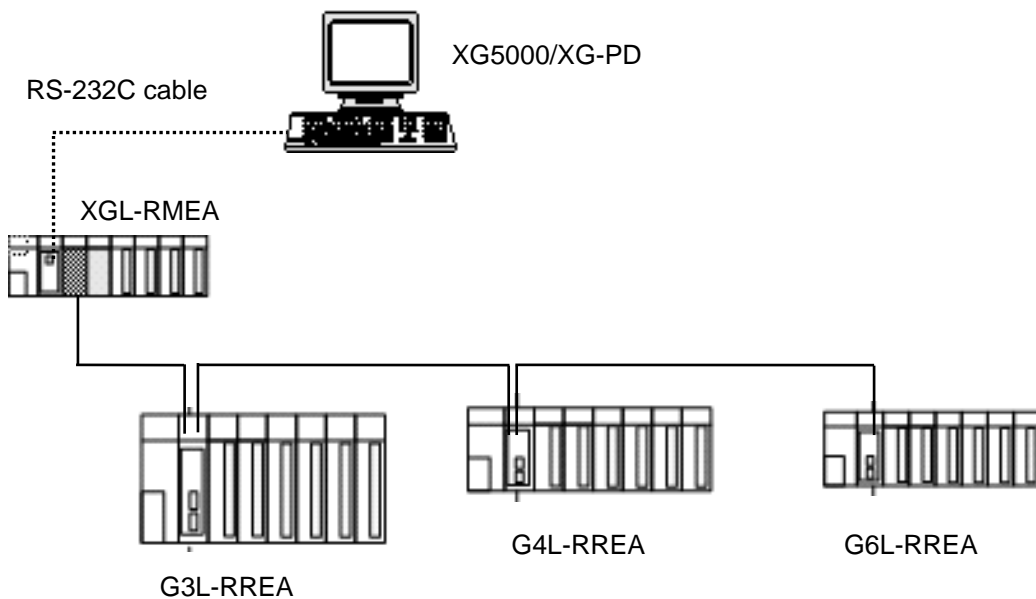

[Fig. 4.1.2] Rack type of remote system

4.1.3 XGL-RMEA + PMU

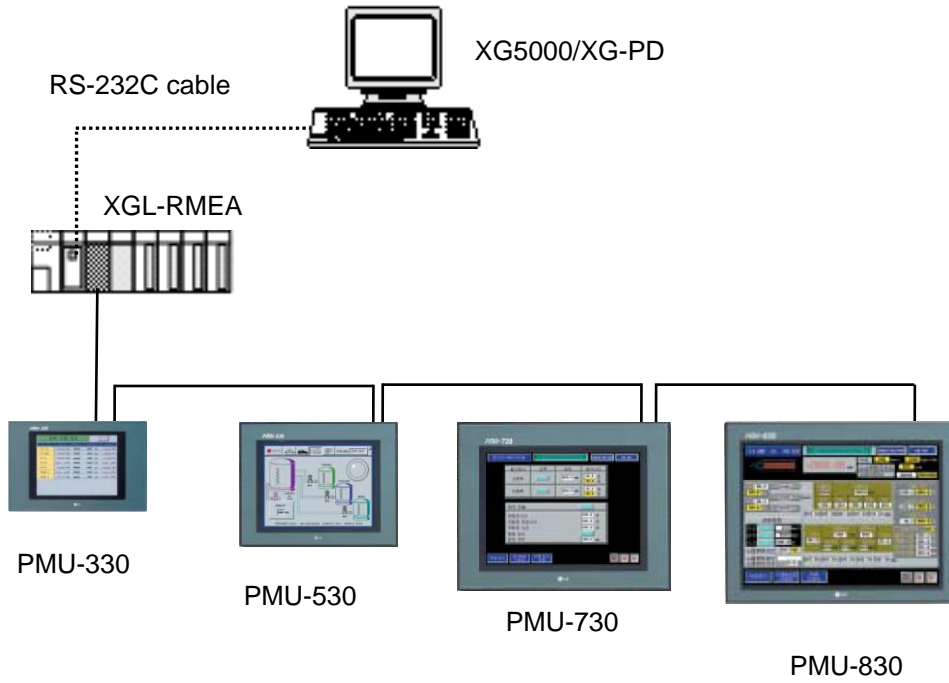

[Fig. 4.1.3] PMU system

4.1.4 XGL-RMEA + Composite system

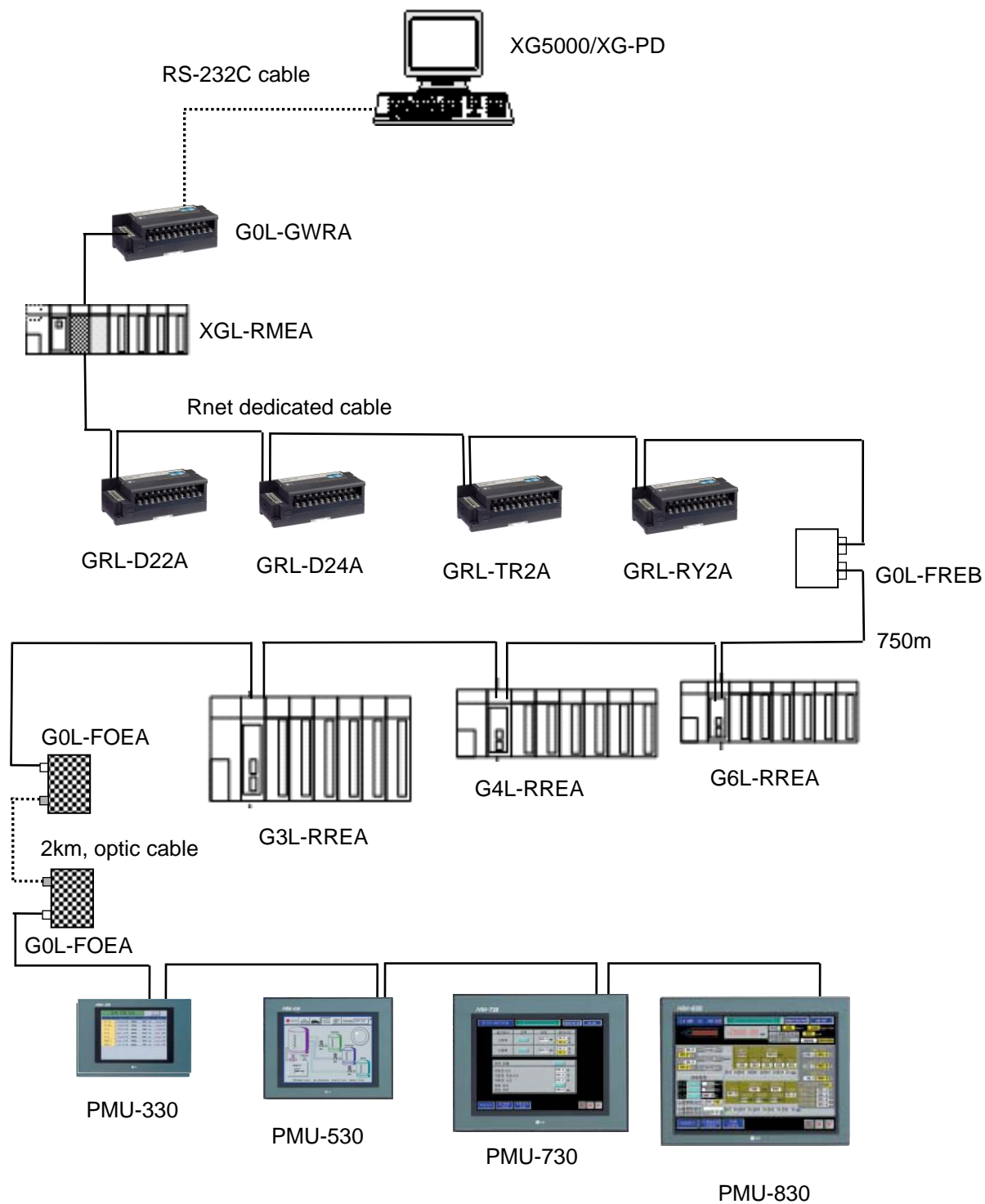

[Fig. 4.1.4] Composite system

Chapter 5 High-speed Link Setting

5.1 Introduction

High-speed link specifies the Send/Receive device area and data size between CPU module and the communication module by XG-PD.

High-speed link can be set the function as shown below.

Description		High-speed Link			
Communication module setting	Communication module setting	Module type	Rnet		
		Base no.	Max.: 0 ~ 7 Setting range is different from CPU module.		
		Slot no.	Max.: 0 ~ 11 Setting range is different from Base type.		
	Communication period setting (Period type)	Select among 20ms, 50ms, 100ms, 200ms, 500ms, 1s, 5s, 10s. - Default setting: 50 ms			
	Output data setup in case of emergency	CPU error	Latch	Keep the previous output status.	
			Clear	Clear the output.	
CPU stop		Latch	Keep the previous output status.		
		Clear	Clear the output.		
High-speed link block setting	Station type *1	Slave			
	Block type *1	Send: Data is transmitted from master module to slave module. Receive: Data is transmitted from slave module to master module.			
	Station No. *1	Slave station number (Range: 0 ~ 63)			
	Block No. *1	It is not used with Rnet I/F module.			
	Read area (From Master to Slave module)	Address	XGK	Head address of the sending device Usable device: P, M, K, F, T, C, U, Z, L, N, D, R, ZR	
			XGI/XGR	Head address of the sending device Usable device: A, M, I, Q, R, W, F, K, L, N, U	
		Size (Byte)	Input/Output point of slave module is displayed Byte. - If input module point is less than 8 bit, it is processed 1 Byte.		
	Save area (From Slave to Master module)	Address	XGK	Head address of the receiving device Usable device: P, M, K, F, T, C, U, Z, L, N, D, R, ZR	
			XGI/XGR	Head address of the receiving device Usable device: A, M, I, Q, R, W, F, K, L, N, U	
		Size (Byte)	Input/Output point of slave module is displayed in Byte. - If input module point is less than 8 bit, it is dealt with 1 Byte.		
PLC connection	RS-232C or USB Port of CPU module				
Control condition	It can control regardless of position of Run mode switch (Run, Stop) of CPU module.				
Max. communication point	60480 points (63 blocks * 120 bytes)				
Max. block number	63 (Setting Range : 0~62)				
Max. point per block	120 bytes (960 points)				
Number of High-speed link setting	Up to 12				

Note

- ▶ When High-speed link is edited, parameter has to download again.
- ▶ High-speed link is used per a communication module.
- ▶ CPU module saves the written parameter (Standard, High-speed link, P2P).
When CPU module is exchanged, parameter in XG-PD has to back-up and then the parameter has to write in CPU module again.

5.2 How to use XG-PD

XG-PD usage for Rnet I/F module is as shown below.

XG-PD execution

- 1) File → New file
 - (1) Project name
 - A) Writing the project name
 - (2) PLC Series
 - A) Selecting PLC series
 - (3) CPU kind
 - A) Selecting CPU kind

Creating New file for Rnet I/F module

2) Reading I/O information

Reading Rnet I/F module information

- 3) High-speed link setting
 - (1) Communication module setting
 - A) Communication module setting: Rnet
 - Module type, Base, Slot
 - B) Communication period setting
 - C) Data setup in case of emergency
 - CPU module error, CPU module stop
 - (2) Block setting
 - Read area/Save area address setting

Connects High-speed link and Rnet I/F module (The module information get through 'Read IO information')

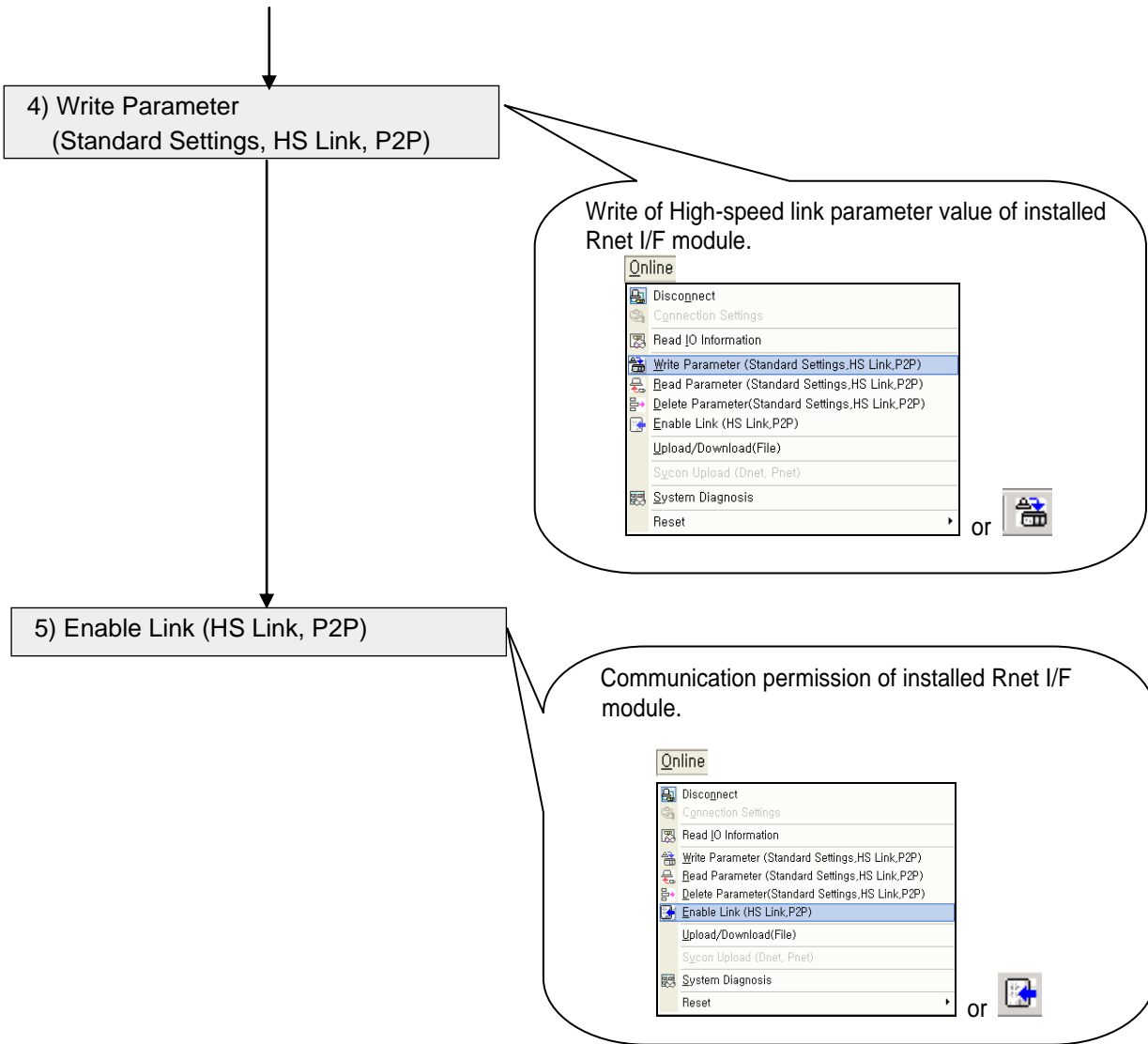

Chapter 5 High-speed Link Setting

* Enable Link through flag

It describes “Enable Link” method through flag. The following XG5000 version, CPU OS version is needed.

Item	Version
XG5000	V3.61 or above
XGR CPU	V1.91 or above
XGI CPU	V3.4 or above
XGK CPU	V3.7 or above

Flag list related with “Enable Link”

-XGR

Flag	Data type	Device	Description
_HS_ENABLE_STATE	ARRAY[0..11] OF BOOL	%FX19040	HS link enable/disable current state
_HS_REQ	ARRAY[0..11] OF BOOL	%FX31520	HS link enable/disable request
_HS_REQ_NUM	ARRAY[0..11] OF BOOL	%FX31536	HS link enable/disable setting
_P2P_ENABLE_STATE	ARRAY[0..7] OF BOOL	%FX19072	P2P enable/disable current state
_P2P_REQ	ARRAY[0..7] OF BOOL	%FX31552	P2P enable/disable request
_P2P_REQ_NUM	ARRAY[0..7] OF BOOL	%FX31568	P2P enable/disable setting

-XGI

Flag	Data type	Device	Description
_HS_ENABLE_STATE	ARRAY[0..11] OF BOOL	%FX15840	HS link enable/disable current state
_HS_REQ	ARRAY[0..11] OF BOOL	%FX16480	HS link enable/disable request
_HS_REQ_NUM	ARRAY[0..11] OF BOOL	%FX16496	HS link enable/disable setting
_P2P_ENABLE_STATE	ARRAY[0..7] OF BOOL	%FX15872	P2P enable/disable current state
_P2P_REQ	ARRAY[0..7] OF BOOL	%FX16512	P2P enable/disable request
_P2P_REQ_NUM	ARRAY[0..7] OF BOOL	%FX16528	P2P enable/disable setting

-XGK

Flag	Data type	Device	Description
_HS1_ENABLE_STATE	BIT	F09600	HS link 1 enable/disable current state
_HS2_ENABLE_STATE	BIT	F09601	HS link 2 enable/disable current state
_HS3_ENABLE_STATE	BIT	F09602	HS link 3 enable/disable current state
_HS4_ENABLE_STATE	BIT	F09603	HS link 4 enable/disable current state
_HS5_ENABLE_STATE	BIT	F09604	HS link 5 enable/disable current state
_HS6_ENABLE_STATE	BIT	F09605	HS link 6 enable/disable current state
_HS7_ENABLE_STATE	BIT	F09606	HS link 7 enable/disable current state
_HS8_ENABLE_STATE	BIT	F09607	HS link 8 enable/disable current state
_HS9_ENABLE_STATE	BIT	F09608	HS link 9 enable/disable current state
_HS10_ENABLE_STATE	BIT	F09609	HS link 10 enable/disable current state
_HS11_ENABLE_STATE	BIT	F0960A	HS link 11 enable/disable current state
_HS12_ENABLE_STATE	BIT	F0960B	HS link 12 enable/disable current state
_HS1_REQ	BIT	F10300	HS link 1 enable/disable request
_HS2_REQ	BIT	F10301	HS link 2 enable/disable request
_HS3_REQ	BIT	F10302	HS link 3 enable/disable request
_HS4_REQ	BIT	F10303	HS link 4 enable/disable request
_HS5_REQ	BIT	F10304	HS link 5 enable/disable request
_HS6_REQ	BIT	F10305	HS link 6 enable/disable request
_HS7_REQ	BIT	F10306	HS link 7 enable/disable request
_HS8_REQ	BIT	F10307	HS link 8 enable/disable request
_HS9_REQ	BIT	F10308	HS link 9 enable/disable request
_HS10_REQ	BIT	F10309	HS link 10 enable/disable request
_HS11_REQ	BIT	F1030A	HS link 11 enable/disable request
_HS12_REQ	BIT	F1030B	HS link 12 enable/disable request
_HS1_REQ_NUM	BIT	F10310	HS link 1 enable/disable setting
_HS2_REQ_NUM	BIT	F10311	HS link 2 enable/disable setting











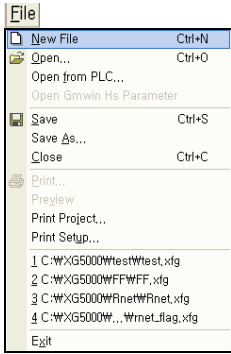



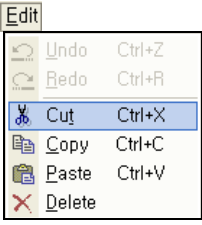

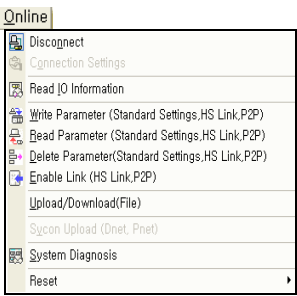

Chapter 5 High-speed Link Setting

Flag	Data type	Device	Description
_HS3_REQ_NUM	BIT	F10312	HS link 3 enable/disable setting
_HS4_REQ_NUM	BIT	F10313	HS link 4 enable/disable setting
_HS5_REQ_NUM	BIT	F10314	HS link 5 enable/disable setting
_HS6_REQ_NUM	BIT	F10315	HS link 6 enable/disable setting
_HS7_REQ_NUM	BIT	F10316	HS link 7 enable/disable setting
_HS8_REQ_NUM	BIT	F10317	HS link 8 enable/disable setting
_HS9_REQ_NUM	BIT	F10318	HS link 9 enable/disable setting
_HS10_REQ_NUM	BIT	F10319	HS link 10 enable/disable setting
_HS11_REQ_NUM	BIT	F1031A	HS link 11 enable/disable setting
_HS12_REQ_NUM	BIT	F1031B	HS link 12 enable/disable setting
_P2P1_ENABLE_STATE	BIT	F09620	P2P1 enable/disable current state
_P2P2_ENABLE_STATE	BIT	F09621	P2P2 enable/disable current state
_P2P3_ENABLE_STATE	BIT	F09622	P2P3 enable/disable current state
_P2P4_ENABLE_STATE	BIT	F09623	P2P4 enable/disable current state
_P2P5_ENABLE_STATE	BIT	F09624	P2P5 enable/disable current state
_P2P6_ENABLE_STATE	BIT	F09625	P2P6 enable/disable current state
_P2P7_ENABLE_STATE	BIT	F09626	P2P7 enable/disable current state
_P2P8_ENABLE_STATE	BIT	F09627	P2P8 enable/disable current state
_P2P1_REQ	BIT	F10320	P2P1 enable/disable request
_P2P2_REQ	BIT	F10321	P2P2 enable/disable request
_P2P3_REQ	BIT	F10322	P2P3 enable/disable request
_P2P4_REQ	BIT	F10323	P2P4 enable/disable request
_P2P5_REQ	BIT	F10324	P2P5 enable/disable request
_P2P6_REQ	BIT	F10325	P2P6 enable/disable request
_P2P7_REQ	BIT	F10326	P2P7 enable/disable request
_P2P8_REQ	BIT	F10327	P2P8 enable/disable request
_P2P1_REQ_NUM	BIT	F10330	P2P1 enable/disable setting
_P2P2_REQ_NUM	BIT	F10331	P2P2 enable/disable setting
_P2P3_REQ_NUM	BIT	F10332	P2P3 enable/disable setting
_P2P4_REQ_NUM	BIT	F10333	P2P4 enable/disable setting
_P2P5_REQ_NUM	BIT	F10334	P2P5 enable/disable setting
_P2P6_REQ_NUM	BIT	F10335	P2P6 enable/disable setting
_P2P7_REQ_NUM	BIT	F10336	P2P7 enable/disable setting
_P2P8_REQ_NUM	BIT	F10337	P2P8 enable/disable setting

- ▶ How to enable link
-HS link/P2P enable/disable setting flag ON → HS link/P2P enable/disable request flag ON
- ▶ How to disable link
-HS link/P2P enable/disable setting flag OFF → HS link/P2P enable/disable request flag ON
- ▶ You can monitor the Enable/Disable state of the each link through “enable/disable current states” flag.

Chapter 5 High-speed Link Setting

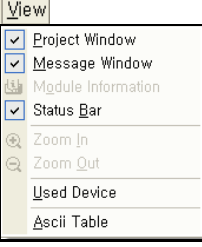
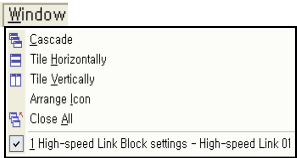
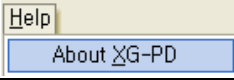
* Relation of Menubar and shortcut

	Menubar	Menu	Icon	Description
File		New File		Create a new file.
		Open...		Open an exiting file.
		Open from PLC...	-	Open the file saved to PLC
		Save		Save the file.
		Save As...	-	Name and save the file.
		Print		Print data.
		Preview	-	Preview the print data.
		Print Project...	-	Print about basic setting, HS link and P2P
		Print Setup...	-	Change the printer settings.
		Edit		Undo/Redo
Cut				Delete an existing content and pastes that another part.
Copy				Copy the data in a file.
Paste				Paste the data in a file.
Delete				Delete the data in a file.
Add Card	-			Not used.
Online				Connect
		Connection settings		Connection settings between PLC and the computer.
		Read IO Information		Read the information of PLC.
		Write Parameter		Write parameter to PLC from XG-PD.
		Read Parameter		Read parameter from PLC to XG-PD.
		Enable Link		Enabling the module to communicate via High-speed link or P2P communication.
		Upload/Download (File)	-	Not used.
		SyCon Upload	-	Not used.
		System Diagnosis		Monitoring of communication module's Run status.
		Reset		Reset the PLC or Reset Individual Module
View		Project Window	-	Display the Project Window
		Message Window	-	Display the Message Window
		Module Information	-	Display the Module Information
		Status Bar	-	Display the Status Bar.
		Zoom in	-	Enlarge the screen of XG-PD
		Zoom out	-	Reduce the screen of XG-PD
		Ascii Table	-	Display the ASCII and Hexadecimal value.
		Window		Cascade
Tile Horizontally	-			Tile the windows horizontally.
Tile Vertically	-			Tile the windows vertically
Arrange Icon	-			Arrange the icon
Close All	-			Close all editing windows
Help		XG-PD Information		Check the XG-PD version information.

5.3 High-speed Link Editing

XG-PD is executed as shown below.

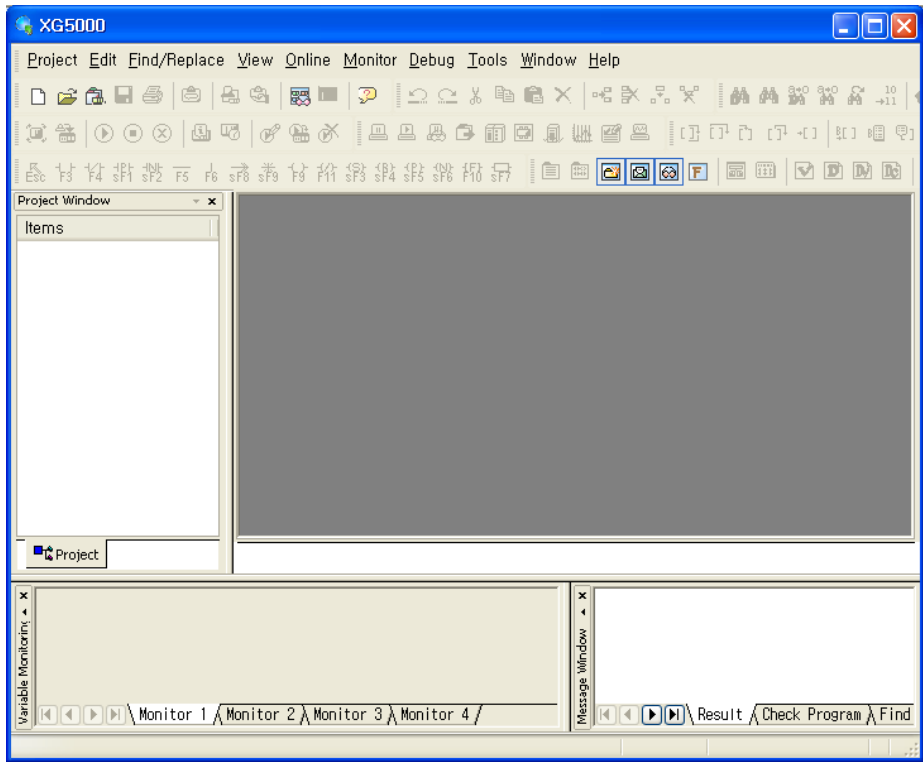

[Standard window]

The parameter in XG-PD is as shown below.

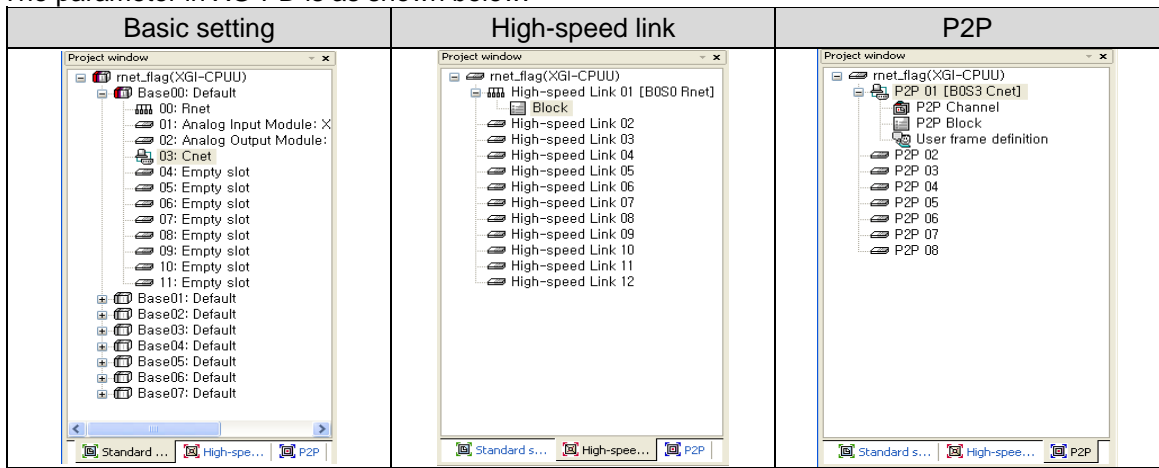

[Parameter window]

Rnet I/F module is set in High-speed link window.

It can use the High-speed link up to maximum 12.

A High-speed link is available per an Rnet I/F module.

Chapter 5 High-speed Link Setting

1) How to use High-speed link window

Parameter is specified at High-speed link window as shown below. There are 2 kinds of parameter setting, Communication module setting and High-speed link block setting.

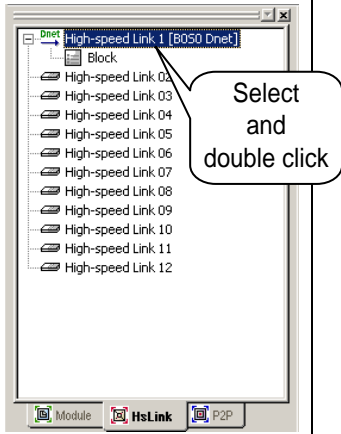
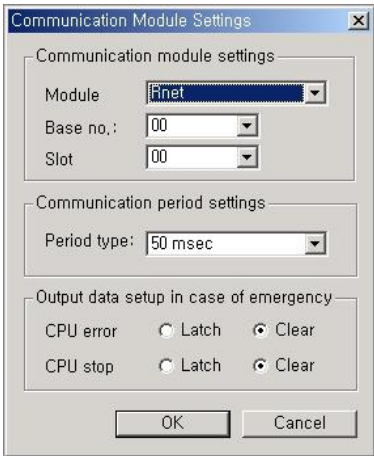
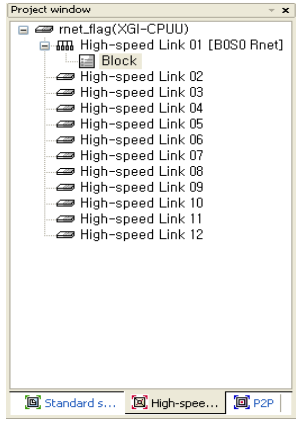
High-speed link	Parameter setting																																																																																																																																																
	<p>Communication module setting</p> 																																																																																																																																																
	<p>High-speed link block setting</p> <table border="1" data-bbox="662 1176 1501 1653"> <thead> <tr> <th>Index</th> <th>Module type</th> <th>Mode</th> <th>Station number</th> <th>Read area</th> <th>Sending data (Byte)</th> <th>Save area</th> <th>Receiving data (Byte)</th> </tr> </thead> <tbody> <tr><td>0</td><td></td><td></td><td></td><td></td><td></td><td></td><td></td></tr> <tr><td>1</td><td></td><td></td><td></td><td></td><td></td><td></td><td></td></tr> <tr><td>2</td><td></td><td></td><td></td><td></td><td></td><td></td><td></td></tr> <tr><td>3</td><td></td><td></td><td></td><td></td><td></td><td></td><td></td></tr> <tr><td>4</td><td></td><td></td><td></td><td></td><td></td><td></td><td></td></tr> <tr><td>5</td><td></td><td></td><td></td><td></td><td></td><td></td><td></td></tr> <tr><td>6</td><td></td><td></td><td></td><td></td><td></td><td></td><td></td></tr> <tr><td>7</td><td></td><td></td><td></td><td></td><td></td><td></td><td></td></tr> <tr><td>8</td><td></td><td></td><td></td><td></td><td></td><td></td><td></td></tr> <tr><td>9</td><td></td><td></td><td></td><td></td><td></td><td></td><td></td></tr> <tr><td>10</td><td></td><td></td><td></td><td></td><td></td><td></td><td></td></tr> <tr><td>11</td><td></td><td></td><td></td><td></td><td></td><td></td><td></td></tr> <tr><td>12</td><td></td><td></td><td></td><td></td><td></td><td></td><td></td></tr> <tr><td>13</td><td></td><td></td><td></td><td></td><td></td><td></td><td></td></tr> <tr><td>14</td><td></td><td></td><td></td><td></td><td></td><td></td><td></td></tr> <tr><td>15</td><td></td><td></td><td></td><td></td><td></td><td></td><td></td></tr> <tr><td>16</td><td></td><td></td><td></td><td></td><td></td><td></td><td></td></tr> </tbody> </table>	Index	Module type	Mode	Station number	Read area	Sending data (Byte)	Save area	Receiving data (Byte)	0								1								2								3								4								5								6								7								8								9								10								11								12								13								14								15								16							
Index	Module type	Mode	Station number	Read area	Sending data (Byte)	Save area	Receiving data (Byte)																																																																																																																																										
0																																																																																																																																																	
1																																																																																																																																																	
2																																																																																																																																																	
3																																																																																																																																																	
4																																																																																																																																																	
5																																																																																																																																																	
6																																																																																																																																																	
7																																																																																																																																																	
8																																																																																																																																																	
9																																																																																																																																																	
10																																																																																																																																																	
11																																																																																																																																																	
12																																																																																																																																																	
13																																																																																																																																																	
14																																																																																																																																																	
15																																																																																																																																																	
16																																																																																																																																																	

Remark

High-speed link1 [B0S0 Rnet] is as shown below.

- 1) High-speed link1: It is a serial number of High-speed link.
- 2) B0: It means Base number 0. (Example: Expansion base 2 stage - B2, Expansion base 5 stage - B5)
- 3) S0: It means Slot number 0. (Example: Slot number 5 - S5, Slot number 11 - S11)

Chapter 5 High-speed Link Setting

2) Communication module setting parameter

Communication module parameter setting is as shown below.

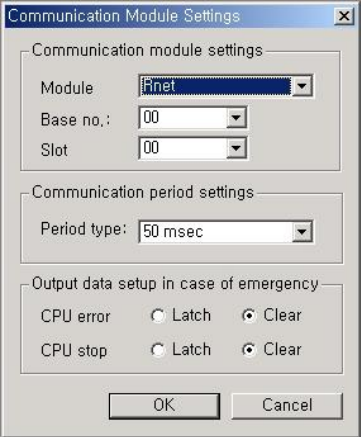
Parameter	Setting item		Description	
	Communication module Setting	Module	Rnet	
		Base no.	Setting range: 0 ~ 7 It is different from CPU module.	
		Slot	Setting range: 0 ~ 11 It is different from type of base.	
	Communication period settings (Period type)			Select among the 20ms, 50ms, 100ms, 200ms, 500ms, 1s, 5s, 10s. - Default: 20ms - It is only for transmission data. - Received data is processed every end of scan program.
	Output data setup in case of emergency	CPU error	Latch	Keep the output status. (But, P device's data is cleared.)
			Clear	Clear all of the output.
		CPU stop	Latch	Keep the output status. (But, P device's data is cleared.)
Clear			Clear all of the output.	

Click  button after the setting is finished.

Remark

Cautions of communication period setting

- Setting value of communication period is applicable to transmission data (CPU module's data → Rnet I/F module). If communication period is longer than the time of changing data at scan program, it might be different from the data which is transmitted to slave module.

Chapter 5 High-speed Link Setting

3) Parameter of High-speed link block setting

High-speed link block setting parameter is as shown below.

Block window							
Index	Module type	Mode	Station number	Read area	Sending data (Byte)	Save area	Receiving data (Byte)
0							
1							
2							
3							
4							
5							
6							
7							
8							

Select by mouse then module type setting screen is opened as shown below.

-	Item	Description	
	Module type	1.DC input 16points	
		GRL-D22A/D22A(N)	
		2.DC input 32points	
		GRL-D24A/D24A(N)	
		3.TR output 16points	
		GRL-TR2A/TR2A(N)	
		4.TR output 32points	
GRL-TR4A/TR4A(N)			
5.Relay output 16points			
GRL-RY2A/RY2A(N)			
6.DC input 16 points/output 16points			
GRL-DT4A/DT4A(N)			
7.GM3,GM4,GM6,PMU			
GM3/4/6L-RREA, PMU			
-	Station type	Auto-setting when module type is set.	
	Mode	Auto-setting when module type is set.	
	Station No.	Slave station number (range: 0 ~ 63)	
	Read area (Master module → Slave module)	Address	XGK Head address of transmitting device. Usable device: P, M, K, F, T, C, U, Z, L, N, D, R, ZR
			XGI Head address of transmitting device. Usable device: A, M, I, Q, R, W, F, K, L, N, U
	Save area (Slave module → Master module)	Address	XGK Head address of receiving device. Usable device: P, M, K, F, T, C, U, Z, L, N, D, R, ZR
			XGI Head address of transmitting device. Usable device: A, M, I, Q, R, W, F, K, L, N, U
	Size(Byte)	Input/Output point of slave module is displayed in Byte. - If input module point is less than 8 bit, it is dealt with 1 Byte.	
Input/Output point of slave module is displayed in Byte. - If input module point is less than 8 bit, it is dealt with 1 Byte.			

The priority order of data is the slave module which has lowest station number.

Remark

Unit of address setting is Word. But slave module's unit size is Byte. Less than 8 point module is processed by 1 Word when address is specified.

Chapter 5 High-speed Link Setting

(3) How to use High-speed link block editing tool

The editing tool and usage of High-speed link block is as shown below.

Index	Module type	Mode	Station number	Read area	Sending data (Byte)	Save area	Receiving data (Byte)
0	TR output 32 points	Send	1	%MW0	4		
1	DC input 32 points	Receive	7			%MW200	4
2							
3							
4							
5							
6							
7							
8							

Screen 1: click right mouse button of a selected area.

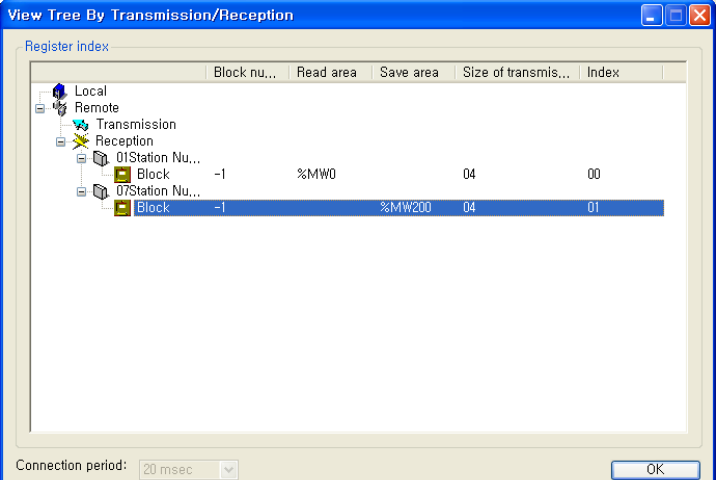
	High-speed ...																													
		<table border="1"> <tr> <td>Undo</td> <td>Ctrl+Z</td> <td>Edit Block</td> <td>Changes the edited index block.</td> </tr> <tr> <td>Redo</td> <td>Ctrl+R</td> <td>Copy Block</td> <td>Copies the edited index block.</td> </tr> <tr> <td>Cut</td> <td>Ctrl+X</td> <td>Paste Block</td> <td>Pastes the copied index block.</td> </tr> <tr> <td>Copy</td> <td>Ctrl+C</td> <td>Delete Block</td> <td>Deletes the edited index block.</td> </tr> <tr> <td>Paste</td> <td>Ctrl+V</td> <td>Lump Setup</td> <td>Read/Save area is specified in a lump when the slave module's data size is regular.</td> </tr> <tr> <td>Delete</td> <td>Delete</td> <td></td> <td></td> </tr> <tr> <td colspan="2">View tree by Transmission/Reception</td> <td></td> <td></td> </tr> </table>	Undo	Ctrl+Z	Edit Block	Changes the edited index block.	Redo	Ctrl+R	Copy Block	Copies the edited index block.	Cut	Ctrl+X	Paste Block	Pastes the copied index block.	Copy	Ctrl+C	Delete Block	Deletes the edited index block.	Paste	Ctrl+V	Lump Setup	Read/Save area is specified in a lump when the slave module's data size is regular.	Delete	Delete			View tree by Transmission/Reception			
Undo	Ctrl+Z	Edit Block	Changes the edited index block.																											
Redo	Ctrl+R	Copy Block	Copies the edited index block.																											
Cut	Ctrl+X	Paste Block	Pastes the copied index block.																											
Copy	Ctrl+C	Delete Block	Deletes the edited index block.																											
Paste	Ctrl+V	Lump Setup	Read/Save area is specified in a lump when the slave module's data size is regular.																											
Delete	Delete																													
View tree by Transmission/Reception																														
[Screen 1]		<table border="1"> <tr> <td>View</td> <td>Display by Tree structure.</td> </tr> <tr> <td>Tree by</td> <td></td> </tr> <tr> <td>Transmission/</td> <td></td> </tr> <tr> <td>Reception</td> <td></td> </tr> </table> 	View	Display by Tree structure.	Tree by		Transmission/		Reception																					
View	Display by Tree structure.																													
Tree by																														
Transmission/																														
Reception																														

Screen 1: Click the right mouse (right click) button of a selected area.

5.4 Read and Write of High-speed Link

The screen is used for read/write of High-speed link's parameter.

(Online menu → Read parameter or Write parameter)

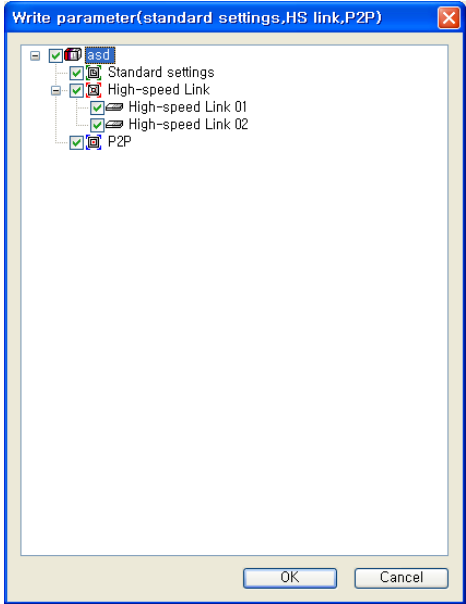
Configuration	Description
	<ol style="list-style-type: none"> 1) High-speed link is available up to 12 for installed Rnet I/F module. <ul style="list-style-type: none"> - It can be used up to 12 with the other communication module which use High-speed link. 2) It can read/write for each High-speed parameter. <ul style="list-style-type: none"> - Check the box to set the High-speed link. 3) Read/Write of High-speed link parameter is not affected to CPU's Run mode.

If a High-speed link parameter is written to a CPU module, the CPU module saves the data. If CPU module is exchanged, the High-speed link parameter has to backup from the CPU module. The parameter has to re-write in exchanged CPU module.

5.5 System Diagnosis

System diagnosis provides the information of Rnet I/F module system. The System diagnosis screen is as shown below.

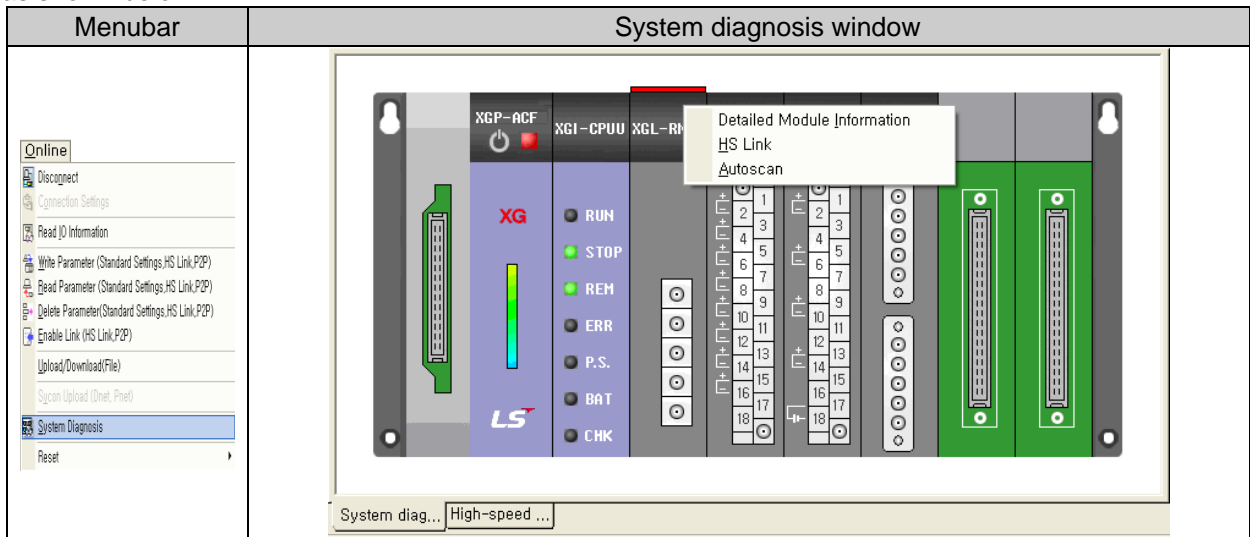

It describes the menu of system diagnosis.

1) Communication module information



Screen configuration and description			
	Standard information	Base	Base number of communication module which is connected with High-speed link.
		Slot no.	Slot number of communication module which is connected with High-speed link.
		Link type	Communication module type.
		Station No.	Station number of master module.
		System parameter	-
		Hardware/Software information	Hardware version
Run mode	Hardware status	Hardware status of communication module.	
	Software version	Software version of communication module.	
	High-speed link	Enable/disable status of high-speed link.	
	Remote	Connection status of local/remote.	

Chapter 5 High-speed Link Setting

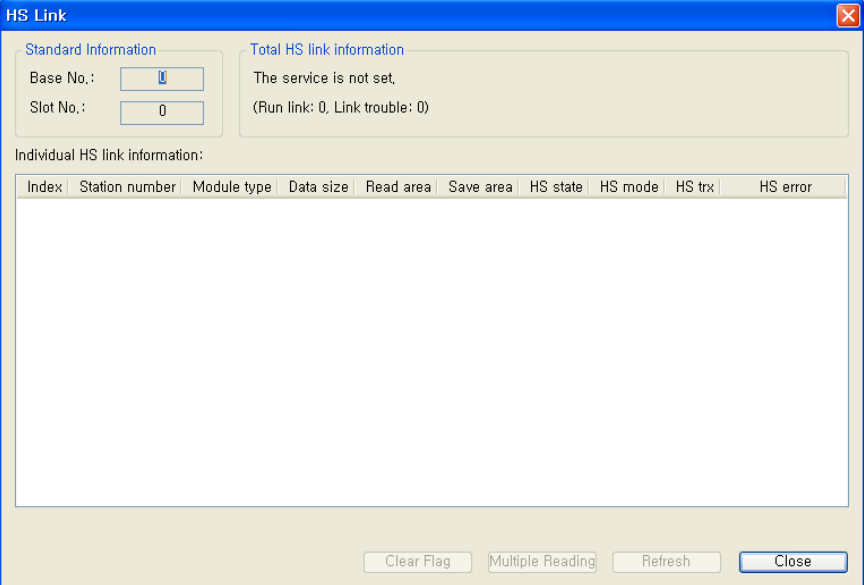
2) HS link

Menu	Screen configuration and description		
HS (High-speed) link information			
	Standard information	Base no.	Base number of communication module which is connected with High-speed link.
		Slot no.	Slot number of communication module which is connected with High-speed link.
	Total HS link information	Run link	Normal: All the slave modules communicate normally.
		Link trouble	Error: Error is occurred in slave station after Run link becomes normal status.
	Individual HS link information	Index	Serial number.
		Station number	Slave module's station number which is existed in network.
		Module type	Module type which is used for setting up of high-speed parameter.
		Data size	Data size of transmitting data from master module to slave module.
		Read area	A device to transmit data from master to slave module.
		Save area	A device to transmit data from slave to master module.
		HsState	Display of communication status between master and slave module.
		HsMode	RUN: Normal communication status between master and slave module. STOP: Abnormal communication status between master and slave module.
HsTrx		Transmission/reception information between master and slave module.	
HsError	Error is displayed while High-speed link data is processed.		

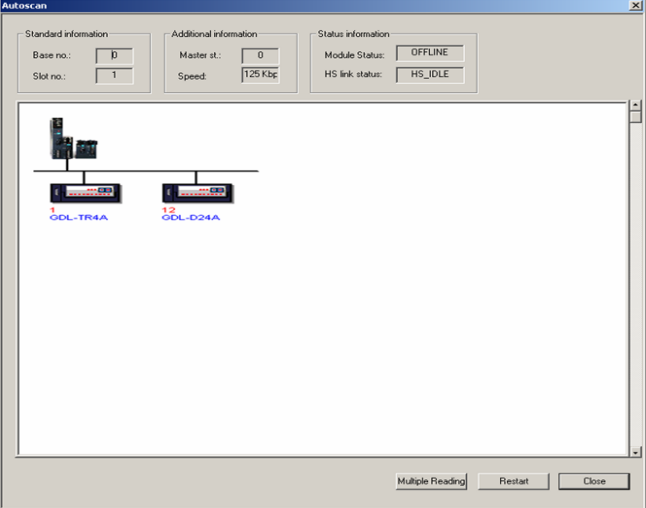
3) Auto-scan

Menu	Screen configuration and description
Auto-scan	
	<p>Communication status of the slave module is displayed as shown below.</p> <p>1) Connected communication : </p> <p>2) Disconnected communication: </p> <p>But, it is not shown about GRL-TR4A which was produced before dated 2007 year during auto-scan.</p>

5.6 High-speed Link Information

High-speed link swaps the data among master module and all slave modules. It provides the flag of High-speed link operation status classified by individual station or total station. It is useful when checking the reliability of Transmission/Reception data and finding cause of error. Flag kinds and usage is as shown below.

Classification	Run-Link	Link-Trouble	Transmission /Reception status	Operation mode	Error	High-speed link status
Information type	All		Respectively			
Flag name (x=High-speed link number)	_HSxRLINK	_HSxLTRBL	_HSxTRX[n] (n=0..63)	_HSxMOD[n] (n=0..63)	_HSxERR[n] (n=0..63)	_HSxSTATE[n] (n=0..63)
Data type	Bit	Bit	Bit Array	Bit Array	Bit Array	Bit Array
Monitoring	Available	Available	Availability	Availability	Availability	Availability
Program use	Available	Availability	Availability	Availability	Availability	Availability

[Table] Function of High-speed link information

The way of selecting flag is as shown below.

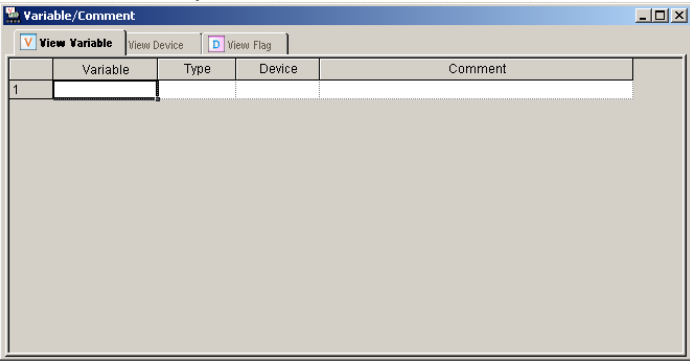
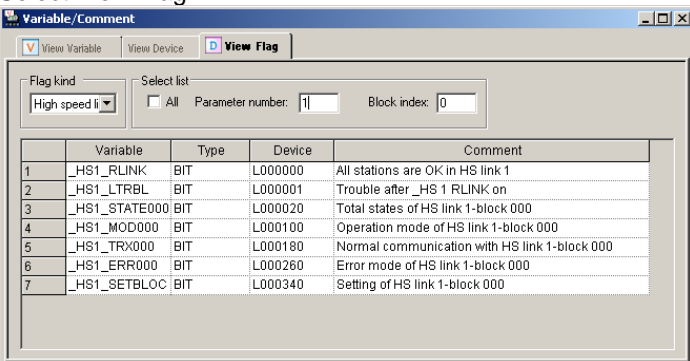
Setting sequence	<p>XG-5000 → Project window → Variable/Comment</p> 																																								
How to use	<p>Select View Flag.</p>  <table border="1" style="width: 100%; border-collapse: collapse; margin-top: 10px;"> <thead> <tr> <th></th> <th>Variable</th> <th>Type</th> <th>Device</th> <th>Comment</th> </tr> </thead> <tbody> <tr> <td>1</td> <td>_HS1_RLINK</td> <td>BIT</td> <td>L000000</td> <td>All stations are OK in HS link 1</td> </tr> <tr> <td>2</td> <td>_HS1_LTRBL</td> <td>BIT</td> <td>L000001</td> <td>Trouble after _HS 1 RLINK on</td> </tr> <tr> <td>3</td> <td>_HS1_STATE000</td> <td>BIT</td> <td>L000020</td> <td>Total states of HS link 1-block 000</td> </tr> <tr> <td>4</td> <td>_HS1_MOD000</td> <td>BIT</td> <td>L000100</td> <td>Operation mode of HS link 1-block 000</td> </tr> <tr> <td>5</td> <td>_HS1_TRX000</td> <td>BIT</td> <td>L000180</td> <td>Normal communication with HS link 1-block 000</td> </tr> <tr> <td>6</td> <td>_HS1_ERR000</td> <td>BIT</td> <td>L000260</td> <td>Error mode of HS link 1-block 000</td> </tr> <tr> <td>7</td> <td>_HS1_SETBLOC</td> <td>BIT</td> <td>L000340</td> <td>Setting of HS link 1-block 000</td> </tr> </tbody> </table>		Variable	Type	Device	Comment	1	_HS1_RLINK	BIT	L000000	All stations are OK in HS link 1	2	_HS1_LTRBL	BIT	L000001	Trouble after _HS 1 RLINK on	3	_HS1_STATE000	BIT	L000020	Total states of HS link 1-block 000	4	_HS1_MOD000	BIT	L000100	Operation mode of HS link 1-block 000	5	_HS1_TRX000	BIT	L000180	Normal communication with HS link 1-block 000	6	_HS1_ERR000	BIT	L000260	Error mode of HS link 1-block 000	7	_HS1_SETBLOC	BIT	L000340	Setting of HS link 1-block 000
	Variable	Type	Device	Comment																																					
1	_HS1_RLINK	BIT	L000000	All stations are OK in HS link 1																																					
2	_HS1_LTRBL	BIT	L000001	Trouble after _HS 1 RLINK on																																					
3	_HS1_STATE000	BIT	L000020	Total states of HS link 1-block 000																																					
4	_HS1_MOD000	BIT	L000100	Operation mode of HS link 1-block 000																																					
5	_HS1_TRX000	BIT	L000180	Normal communication with HS link 1-block 000																																					
6	_HS1_ERR000	BIT	L000260	Error mode of HS link 1-block 000																																					
7	_HS1_SETBLOC	BIT	L000340	Setting of HS link 1-block 000																																					
	<table border="1" style="width: 100%; border-collapse: collapse;"> <tr> <td style="width: 15%;">Flag kind</td> <td colspan="2">Select among the System/High-speed link/P2P/PID.</td> </tr> <tr> <td rowspan="3" style="vertical-align: middle;">Select list</td> <td style="width: 20%;">All</td> <td>It is showed the list of all High-speed links.</td> </tr> <tr> <td>Parameter number</td> <td>It means High-speed link number. The selected number is only displayed in List.</td> </tr> <tr> <td>Block index</td> <td>It is index number of High-speed link block.</td> </tr> </table>	Flag kind	Select among the System/High-speed link/P2P/PID.		Select list	All	It is showed the list of all High-speed links.	Parameter number	It means High-speed link number. The selected number is only displayed in List.	Block index	It is index number of High-speed link block.																														
Flag kind	Select among the System/High-speed link/P2P/PID.																																								
Select list	All	It is showed the list of all High-speed links.																																							
	Parameter number	It means High-speed link number. The selected number is only displayed in List.																																							
	Block index	It is index number of High-speed link block.																																							

Chapter 5 High-speed Link Setting

Monitoring of flag and device's value is as shown below.

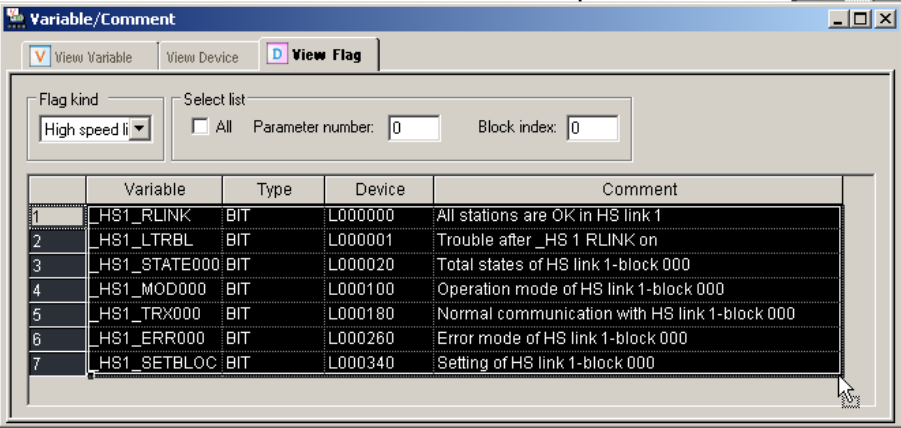
Setting sequence	<p>XG5000 → Project window → Variable/Comment</p>  <table border="1"> <thead> <tr> <th></th> <th>Variable</th> <th>Type</th> <th>Device</th> <th>Comment</th> </tr> </thead> <tbody> <tr> <td>1</td> <td>HS1_RLINK</td> <td>BIT</td> <td>L000000</td> <td>All stations are OK in HS link 1</td> </tr> <tr> <td>2</td> <td>HS1_LTRBL</td> <td>BIT</td> <td>L000001</td> <td>Trouble after _HS 1 RLINK on</td> </tr> <tr> <td>3</td> <td>HS1_STATE000</td> <td>BIT</td> <td>L000020</td> <td>Total states of HS link 1-block 000</td> </tr> <tr> <td>4</td> <td>HS1_MOD000</td> <td>BIT</td> <td>L000100</td> <td>Operation mode of HS link 1-block 000</td> </tr> <tr> <td>5</td> <td>HS1_TRX000</td> <td>BIT</td> <td>L000180</td> <td>Normal communication with HS link 1-block 000</td> </tr> <tr> <td>6</td> <td>HS1_ERR000</td> <td>BIT</td> <td>L000260</td> <td>Error mode of HS link 1-block 000</td> </tr> <tr> <td>7</td> <td>HS1_SETBLOC</td> <td>BIT</td> <td>L000340</td> <td>Setting of HS link 1-block 000</td> </tr> </tbody> </table>		Variable	Type	Device	Comment	1	HS1_RLINK	BIT	L000000	All stations are OK in HS link 1	2	HS1_LTRBL	BIT	L000001	Trouble after _HS 1 RLINK on	3	HS1_STATE000	BIT	L000020	Total states of HS link 1-block 000	4	HS1_MOD000	BIT	L000100	Operation mode of HS link 1-block 000	5	HS1_TRX000	BIT	L000180	Normal communication with HS link 1-block 000	6	HS1_ERR000	BIT	L000260	Error mode of HS link 1-block 000	7	HS1_SETBLOC	BIT	L000340	Setting of HS link 1-block 000																							
	Variable	Type	Device	Comment																																																												
1	HS1_RLINK	BIT	L000000	All stations are OK in HS link 1																																																												
2	HS1_LTRBL	BIT	L000001	Trouble after _HS 1 RLINK on																																																												
3	HS1_STATE000	BIT	L000020	Total states of HS link 1-block 000																																																												
4	HS1_MOD000	BIT	L000100	Operation mode of HS link 1-block 000																																																												
5	HS1_TRX000	BIT	L000180	Normal communication with HS link 1-block 000																																																												
6	HS1_ERR000	BIT	L000260	Error mode of HS link 1-block 000																																																												
7	HS1_SETBLOC	BIT	L000340	Setting of HS link 1-block 000																																																												
How to use	<p>XG5000 → View → Variable Monitoring Window</p> <table border="1"> <thead> <tr> <th></th> <th>PLC</th> <th>Type</th> <th>Device</th> <th>Value</th> <th>Variable</th> <th>Comment</th> </tr> </thead> <tbody> <tr> <td>1</td> <td>NewPLC</td> <td>BIT</td> <td>L000000</td> <td>10</td> <td>_HS1_RLINK</td> <td>All stations are OK in HS link 1</td> </tr> <tr> <td>2</td> <td>NewPLC</td> <td>BIT</td> <td>L000001</td> <td>10</td> <td>_HS1_LTRBL</td> <td>Trouble after _HS 1 RLINK on</td> </tr> <tr> <td>3</td> <td>NewPLC</td> <td>BIT</td> <td>L000020</td> <td>10</td> <td>_HS1_STATE000</td> <td>Total states of HS link 1-block 000</td> </tr> <tr> <td>4</td> <td>NewPLC</td> <td>BIT</td> <td>L000100</td> <td>10</td> <td>_HS1_MOD000</td> <td>Operation mode of HS link 1-block 000</td> </tr> <tr> <td>5</td> <td>NewPLC</td> <td>BIT</td> <td>L000180</td> <td>10</td> <td>_HS1_TRX000</td> <td>Normal communication with HS link 1-block 000</td> </tr> <tr> <td>6</td> <td>NewPLC</td> <td>BIT</td> <td>L000260</td> <td>10</td> <td>_HS1_ERR000</td> <td>Error mode of HS link 1-block 000</td> </tr> <tr> <td>7</td> <td>NewPLC</td> <td>BIT</td> <td>L000340</td> <td>10</td> <td>_HS1_SETBLOCK</td> <td>Setting of HS link 1-block 000</td> </tr> <tr> <td>8</td> <td></td> <td></td> <td></td> <td></td> <td></td> <td></td> </tr> </tbody> </table> <p>- Select variable in Variable/Comment screen and then Drag/Drop the variable to Variable Monitoring Window. The value is appeared in variable Monitoring Window.</p>		PLC	Type	Device	Value	Variable	Comment	1	NewPLC	BIT	L000000	10	_HS1_RLINK	All stations are OK in HS link 1	2	NewPLC	BIT	L000001	10	_HS1_LTRBL	Trouble after _HS 1 RLINK on	3	NewPLC	BIT	L000020	10	_HS1_STATE000	Total states of HS link 1-block 000	4	NewPLC	BIT	L000100	10	_HS1_MOD000	Operation mode of HS link 1-block 000	5	NewPLC	BIT	L000180	10	_HS1_TRX000	Normal communication with HS link 1-block 000	6	NewPLC	BIT	L000260	10	_HS1_ERR000	Error mode of HS link 1-block 000	7	NewPLC	BIT	L000340	10	_HS1_SETBLOCK	Setting of HS link 1-block 000	8						
	PLC	Type	Device	Value	Variable	Comment																																																										
1	NewPLC	BIT	L000000	10	_HS1_RLINK	All stations are OK in HS link 1																																																										
2	NewPLC	BIT	L000001	10	_HS1_LTRBL	Trouble after _HS 1 RLINK on																																																										
3	NewPLC	BIT	L000020	10	_HS1_STATE000	Total states of HS link 1-block 000																																																										
4	NewPLC	BIT	L000100	10	_HS1_MOD000	Operation mode of HS link 1-block 000																																																										
5	NewPLC	BIT	L000180	10	_HS1_TRX000	Normal communication with HS link 1-block 000																																																										
6	NewPLC	BIT	L000260	10	_HS1_ERR000	Error mode of HS link 1-block 000																																																										
7	NewPLC	BIT	L000340	10	_HS1_SETBLOCK	Setting of HS link 1-block 000																																																										
8																																																																

Chapter 6 Remote Communication Control

6.1 Introduction

This function is for programming, download of user program, program debugging, monitoring, etc in the network system where PLCs are connected with XGT communication module by remote control without moving the physical connection status of program tool (XG5000/XG-PD). Especially it is convenient for easy access to each PLC from a place without repositioning when network-connected devices are separated far. Communication service function creates the following path to attain its purpose.

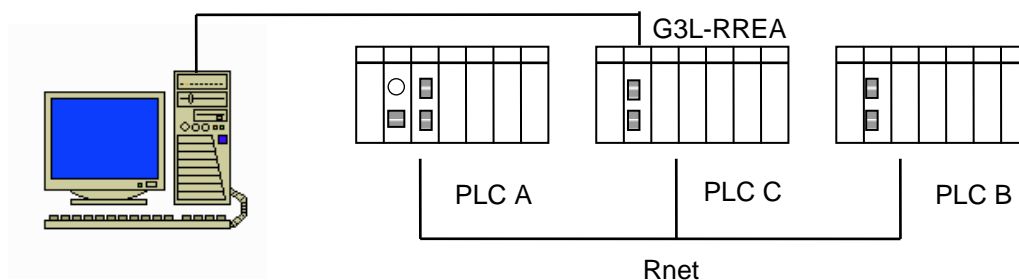

[Fig. 6.1.1] Remote connection network

A network is supposed where RS-232C cable is connected with G3L-RREA module, PLC A with the master and PLC C with Rnet remote I/F module each other in the program tool (XG5000, XG-PD) of the computer. In order to access the contents of PLC A station in the figure above, select the station no. of PLC A's communication module (destination station no. to connect) and the slot no. of G3L-RREA (slot no.0 where RREA's communication module presently connected is installed) to remote-connect with RS-232C via Rnet with remote 1 connection of the program tool.

This status as processed identically to connection with RS-232C cable as moved to PLC A station is available to execute all functions of programming, download, debugging and monitoring. With this remote communication service, easy access to PLC position in the distance is available without moving thereto, which is useful for maintenance of PLC system.

Notes

- 1) Rnet I/F modules for which remote 1 connection is available are **G3L-RREA** and **G0L-GWRA**.

6.2 Remote connection example of XG5000/XG-PD

The remote 1 connection is available for both XG-PD and XG5000.

6.2.1 Remote 1 connection

For remote 1 connection, XG5000 (or XG-PD) shall be in off-line status. In this status, select “Online – Connection Settings” from the menu on the upper of the program.

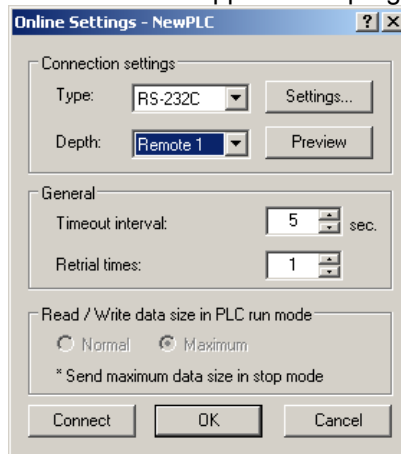

[Fig. 6.2.1] Online Settings

On the communication options setting menu, set “Connection Depth” to Remote 1, and select “Settings” to specify the details.

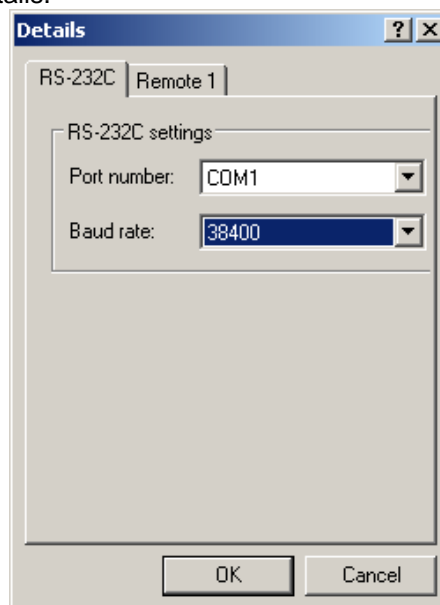

[Fig. 6.2.2] Details screen of RS-232C

Chapter 6 Remote Communication Control

Item		Details
RS-232C setting	Port number	Set the port RS-232C is connected with.
	Baud rate	Set the data communication speed via RS-232C to "38400".

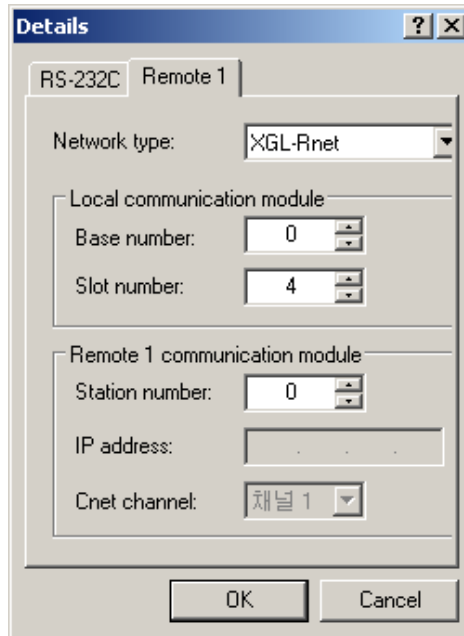

[Fig. 6.2.3] Details screen of remote 1

Item		Details
Network type		Select applicable network module. Select XGT-Rnet here.
Local communication module	Base number	Select the base no. of the communication module installed on the master to be connected with destination station by stage 1 connection.
	Slot number	Select the slot no. of the communication module installed on the master to be connected with destination station by stage 1 connection.
Remote 1 communication module	Station number	Select the station no. of the communication module installed on destination station's PLC to be connected by stage 1. (select station 0)
	IP address	Specify if Ethernet I/F module is used.
	Cnet channel	Specify if Cnet I/F module is used.

Click [Preview] on the communication setting window in order to OK settings of remote 1 connection.

Chapter 6 Remote Communication Control

Select “Preview” button on “Connection Settings” window to see the remote 1 PLC configuration.

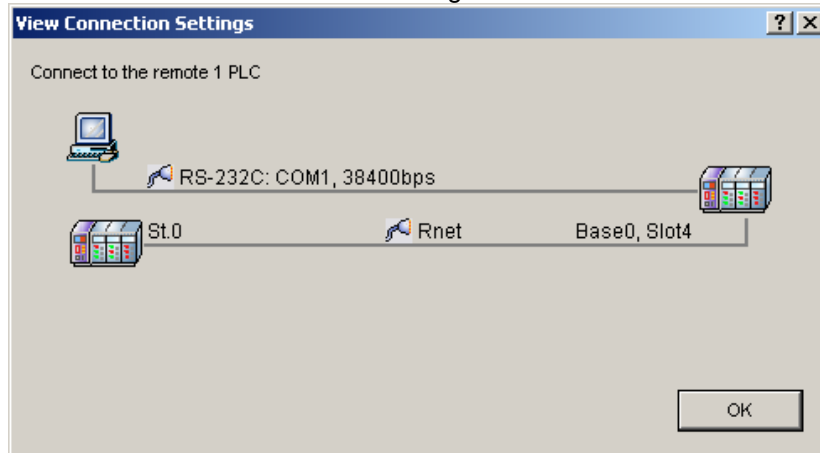

[Fig. 6.2.4] Details screen of connection setting

After setting, click [OK] to escape from the option screen, and then execute the online connection. If connection fails, the following message will appear.



[Fig. 6.2.5] Remote 1 connection failed

The connection setting or communication cable could be abnormal. Check the cable connection and connection setting.

The following message will appear if the PLC type connected to the stage 1 is different from the current project's CPU type. It should be changed the CPU type to connect with.



[Fig. 6.2.6] [CPU type is incorrect]

Completion status of a stage 1 connection is a local connection that is the same with RS-232C cable connection. All online menus are available.

Chapter 7 Program Example

7.1 XG5000 program

7.1.1 Program for XGK-CPUH

How to set High-speed link parameters in Rnet system will be described below.

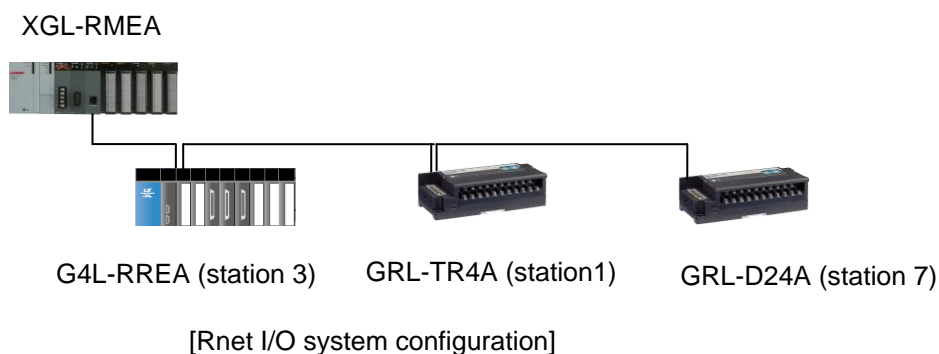

Slave	Station No.	Read area(XGT)	Tx size (byte)	Save area(XGT)	Rx size (byte)
G4L-RREA	3	D00100	6	P0000	-
		P0000	-	D00300	8
GRL-TR4A	1	D00103	4	-	-
GRL-D24A	7	-	-	D00304	4

[Tx/Rx map of High-speed link]

Input/Output configuration for G4L-RREA(Please change mode switch of front part of it to MK mode)

Power	Comm.	Slot 0	Slot 1	Slot 2	Slot 3	Slot 4	Slot 5
GM4-PA2A	G4L-RREA	G4Q-TR2A	G4Q-TR4A	G4I-A22A	Empty	Empty	Empty
Size		1 Word	2 Word	1 Word	-	-	-

In the example, XGT CPU transmits 3-word (D00100~D00102) data of D00100 area to G4L-RREA's Slot no. 0(D00100), and Slot no. 1(D00101~D00102). You have to set Rx size including output module size in front of input module for receiving input data of G4L-RREA. If you set Save area to D00300 and Rx size to 8 byte for receiving input data of G4I-A22A, D00300~D00302 is to be output data area and input data of G4I-A22A is saved to D00303 area.

Chapter 7 Program Example

A) High-speed link parameters setting

It is convenient to user prepare data Tx/Rx map in order to let the stations exchange data. And for data Tx/Rx, High-speed link parameters shall be prepared and downloaded onto PLC as in the sequence described below so to start High-speed link.

- A. Prepare data Tx/Rx map
- B. Local-connect XG-PD software with XGT CPU
- C. On XG-PD's High-speed link parameters setting option, set applicable parameters
- D. Write parameters on the Online menu
- E. Select Link Enable setting on the Online menu to set High-speed Link Enable applicable to setting number
- F. Use the diagnosis service to check High-speed link status
- G. If any error occurs during the procedures F, execute again from A

Chapter 7 Program Example

It is as below to setting procedure for Rnet I/O system configuration example.

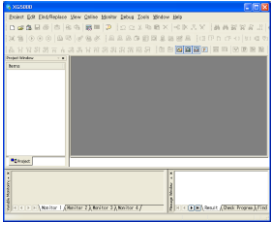
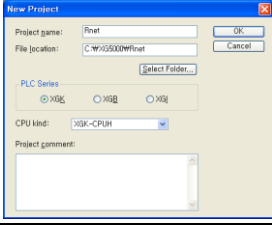
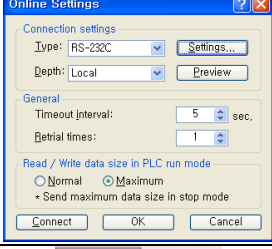
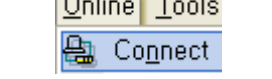
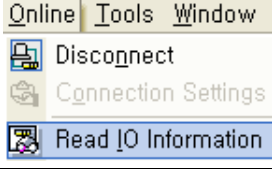
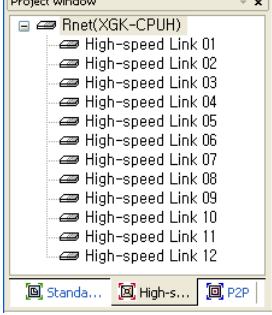
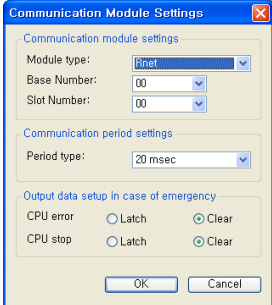
No.	XG-PD	Operation	Description
1		Execute XG-PD	XG5000 → Tools → Network manager
2		Create New project	File → New file Project name, Setting the CPU kind Ex) Rnet, XGK-CPUH
3		Setting connection of XG-PD	XG-PD → Online → Selecting applicable to connection drive in connection setting
4		XG-PD connection	XG-PD → Online → Connection
5		Read I/O information	XG-PD → Online → Read I/O information
6		Setting high speed link project	setting the "high speed link" in XG-PD screen
7		Setting the communication module	Setting the Module type, base no., slot no. and period type as selecting and double click one among "High-speed Link 01" ~ "High-speed Link 12"

Chapter 7 Program Example

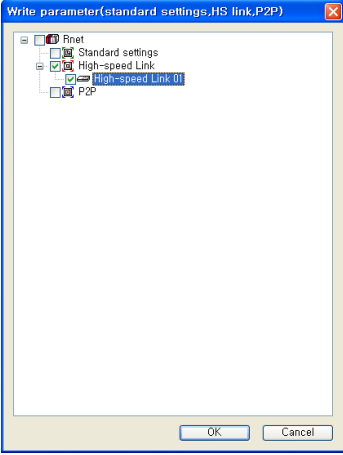
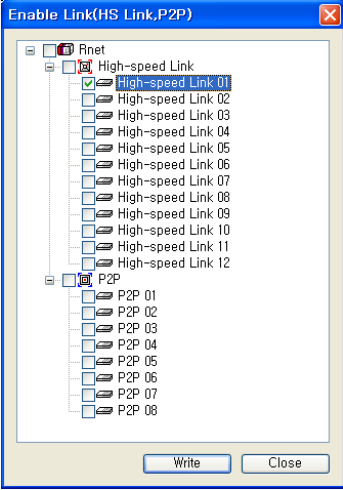
			-	Module type	Mode	Station no	Read area	Save area
8	-	Setting the high speed link block	GRL-TR4A	4.TR output 32p	1.Send	1	D00103	-
			GRL-D24A	2.DC input 32p	2.Receive	7	-	D00304
			G4L-RREA	7.GM3,GM4,GM6, PMU	1.Send	3	D00100	P0000
				7.GM3,GM4,GM6, PMU	2.Receive	3	P0000	D00300
9		Writing the high speed link parameter	Online → Writing the parameter : writing after checking applicable to high speed link					
10		High speed link enable	Online → Link enable : enabling applicable to high speed link					

[Setting procedure of High-speed link parameter]

Chapter 7 Program Example

The parameter setting result is as follow.

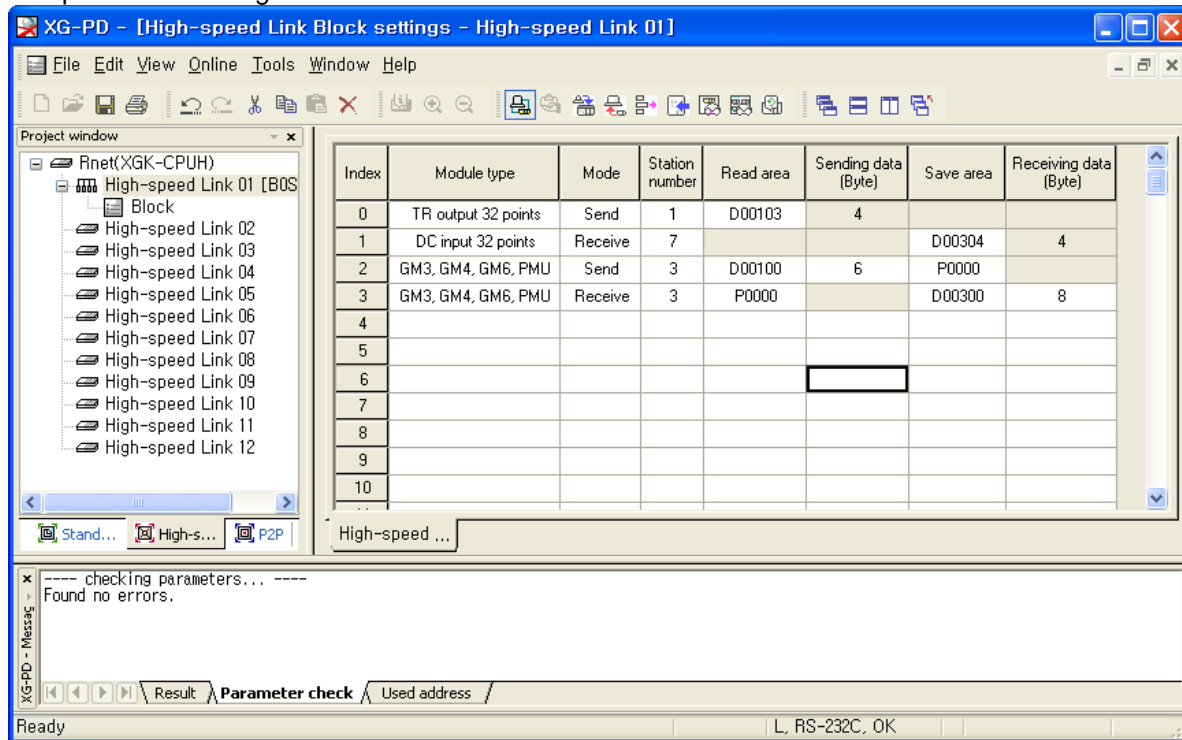

[Setting of High-speed link parameter]

If High-speed link parameters are downloaded during operation of High-speed link, Link enabled will be automatically disabled, and then enabled after downloading is complete.

Chapter 7 Program Example

7.1.2 Program for XGI-CPUU

How to set High-speed link parameters in Rnet system will be described below.



[Rnet I/O system configuration]

Slave	Station No.	Read area	Tx size (byte)	Save area	Rx size (byte)
G4L-RREA	3	%MW0(XGT)	16	%QW0.0.0 (G4L-RREA)	-
		%QW0.0.0 (G4L-RREA)	-	%MW500(XGT)	24
GRL-TR4A	1	%MW8	4	-	-
GRL-D24A	7	-	-	%MW200	4

[Tx/Rx map of High-speed link]

Input/Output configuration for G4L-RREA(Please change mode switch of front part of it to GM mode)

Power	Comm.	Slot 0	Slot 1	Slot 2	Slot 3	Slot 4	Slot 5
GM4-PA2A	G4L-RREA	G4Q-TR2A	G4Q-TR4A	G4I-A22A	Empty	Empty	Empty
Size		1 Word	2 Word	1 Word	-	-	-
XGI		4 Words	4 Words	4 Words	4 Words	4 Words	4 Words

In the example, XGT CPU transmits 8-word (%MW0~%MW7) data of %MW0 area to G4L-RREA's Slot no. 0(%MW0~%MW3), and Slot no. 1(%MW4~%MW7). You have to set Rx size including output module size in front of input module for receiving input data of G4L-RREA. If you set Save area to %MW500 and Rx size to 24 byte for receiving input data of G4I-A22A, %MW500~%MW507 is to be output data area and input data of G4I-A22A is saved to %MW508 area.

Chapter 7 Program Example

A) High-speed link parameters setting

It is convenient to user prepare data Tx/Rx map in order to let the stations exchange data. And for data Tx/Rx, High-speed link parameters shall be prepared and downloaded onto PLC as in the sequence described below so to start High-speed link.

- A. Prepare data Tx/Rx map
- B. Local-connect XG-PD software with XGT CPU
- C. On XG-PD's High-speed link parameters setting option, set applicable parameters
- D. Write parameters on the Online menu
- E. Select Link Enable setting on the Online menu to set High-speed Link Enable applicable to setting number
- F. Use the diagnosis service to check High-speed link status
- G. If any error occurs during the procedures F, execute again from A

Chapter 7 Program Example

It is as below to setting procedure for Rnet I/O system configuration example.

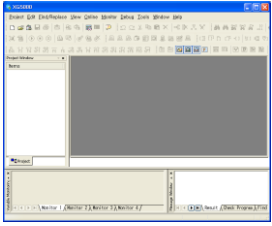
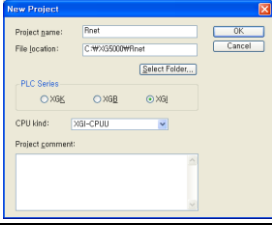
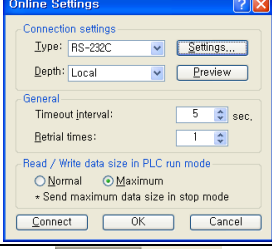
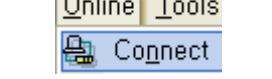
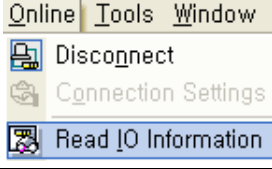
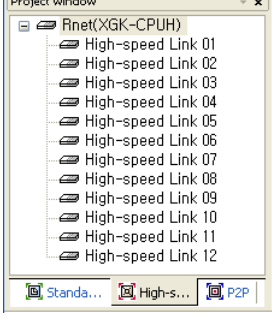
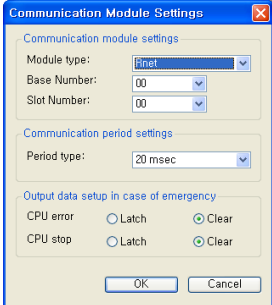
No.	XG-PD	Operation	Description
1		Execute XG-PD	XG5000 → Tools → Network manager
2		Create New project	File → New file Project name, Setting the CPU kind Ex) Rnet, XGI-CPUU
3		Setting connection of XG-PD	XG-PD → Online → Selecting applicable to connection drive in connection setting
4		XG-PD connection	XG-PD → Online → Connection
5		Read I/O information	XG-PD → Online → Read I/O information
6		Setting high speed link project	setting the "high speed link" in XG-PD screen
7		Setting the communication module	Setting the Module type, base no., slot no. and period type as selecting and double click one among "High-speed Link 01" ~ "High-speed Link 12"

Chapter 7 Program Example

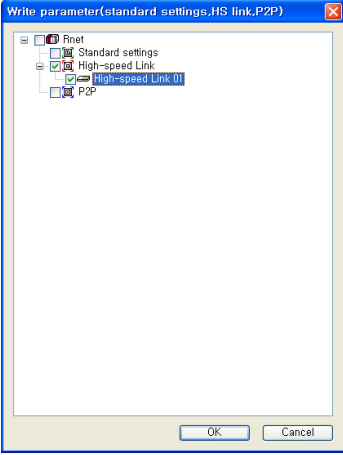
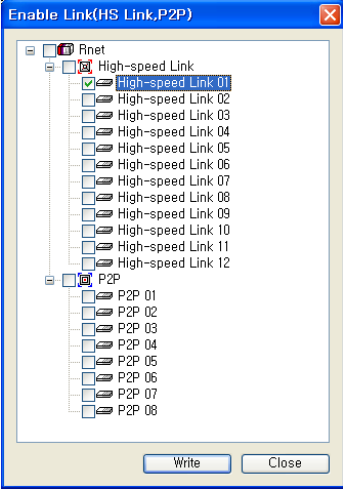
			-	Module type	Mode	Station no.	Read area	Save area
8	-	Setting the high speed link block	GRL-TR4A	4.TR output 32p	1.Send	1	%MW8	-
			GRL-D24A	2.DC input 32p	2.Receive	7	-	%MW200
			G4L-RREA	7.GM3,GM4,GM6, PMU	1.Send	3	%MW2	%QW0.0.0
				7.GM3,GM4,GM6, PMU	2.Receive	3	%QW0.0.0	%MW500
9		Writing the high speed link parameter	Online → Writing the parameter : writing after checking applicable to high speed link					
10		High speed link enable	Online → Link enable : enabling applicable to high speed link					

[Setting procedure of High-speed link parameter]

Chapter 7 Program Example

The parameter setting result is as follow.

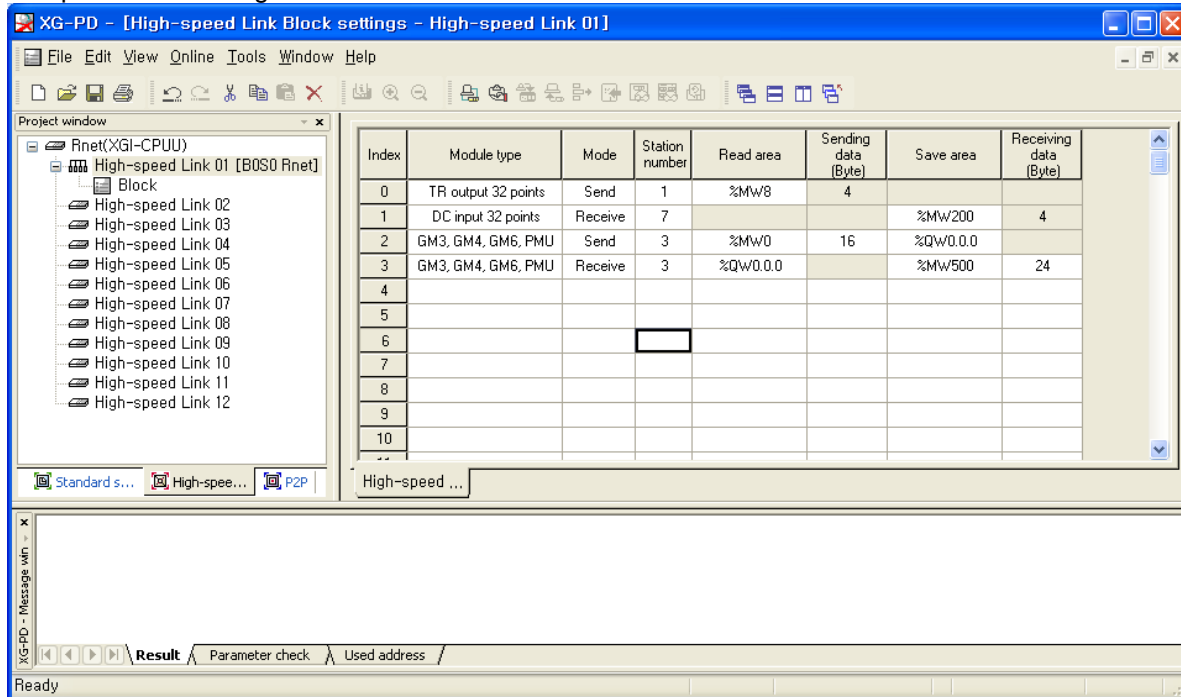

[Setting of High-speed link parameter]

If High-speed link parameters are downloaded during operation of High-speed link, Link enabled will be automatically disabled, and then enabled after downloading is complete.

A.1 Terminology

1) Master Module

Rnet I/F module to be installed on I/O location of the basic base.

2) Slave Module (RSM : Rnet Slave Module)

Rnet I/F module and single module to be installed on CPU location of the basic base.

3) Local Station

Station directly connected with XG-5000, XG-PD in the same network including CPU for user to download, monitoring and debug programs.

4) Remote Station

Contrary to local station, it is the destination station to communicate with local station.

5) Remote I/O Station

I/O area where remote communication module instead of PLC CPU receives I/O data from master station and refreshes I/O module installed on remote station in PLC system.

6) Rnet

Fieldbus, as the lowest network to connect control device with relay device has adopted 3 layers among OSI's 7 layers. The 3 layers are composed of physical layer configured with H2(1Mbps electric), H1 (31.23Kbbs electric), optic/wireless, etc., data link layer with Scheduled and Circulated Token bus and application layer in charge of application function where user layer is adopted additionally.

7) Token

It is a right to send data of self-station by access right control over Physical Medium.

8) Rnet Station no.

Station no. of the communication module to which Rnet standard is applied.

Station no. of XGT-RMEA is always set to '0'.

9) Repeater

It is used to extend cable length in electric communication network, which extends communication distance by revival and amplification of electric communication signals.

10) Manchester Biphase-L

It is a data modulating method used in Rnet. Data is sent as encoded by Manchester-I Code and the data received as encoded by Manchester is converted as decoded.

11) Reset Individual Module

It is used to initialize if an error occurs on the communication module. It operates Reset operation selecting the [Online] → [Reset] → [Reset Individual Module] by XG-PD. Then PLC do Restart operation to initialize.

Appendix

A.2 List of HS Link Flags

No.	Keyword	Type	Detail	Description
L000000	_HS1_RLINK	Bit	HS link parameter No.1's all stations normally operated	Displays all stations normally operated as specified in HS link parameter, which will be On if 1. There is no error with all stations specified in parameter in RUN mode 2. All data block is in normal communication as specified in parameter. 3. The parameter specified in each station itself is in normal communication. Run_link will be kept On if once On until stopped by link disenable.
L000001	_HS1_LTRBL	Bit	After _HS1RLINK is ON, abnormal status displayed	This flag will be On if the station specified in parameter and the data block's communication status are as described below with _HSmRLINK flag On., 1. When the station specified in parameter is not in RUN mode, 2. When the station specified in parameter is in error, 3. When data block's communication status specified in parameter is unstable, The link trouble will be On if one of those conditions 1,2 and 3 above occurs. And if such a condition is back to normal, it will be Off.
L000020 ~ L00009F	_HS1_STATE[k] (k=000~127)	Bit Array	HS link parameter No.1, Block No.k's general status displayed	Displays the general status of the communication information for the specified parameter's respective data blocks. _HS1_STATE[k]=_HS1_MOD[k]&_HS1_TRX[k]&(~_HSm_ERR[k])
L000100 ~ L00017F	_HS1_MOD[k] (k=000~127)	Bit Array	HS link parameter No.1, Block No.k station's Run operation mode	Displays the operation mode of the station specified in parameter's data block k.
L000180 ~ L00025F	_HS1_TRX[k] (k=000~127)	Bit Array	Normal communication displayed with HS link parameter No.1, Block No.k station	Displays the communication status of parameter's data block k to check if normal as specified.
L000260 ~ L00033F	_HS1_ERR[k] (k=000~127)	Bit Array	HS link parameter No.1, Block No.k station's Run error mode	Displays the communication status of parameter's data block k to check for any error.
L000340 ~ L00041F	_HS1_SETBLO CK[k]	Bit Array	HS link parameter No.1, Block No.k setting displayed	Displays the setting status of parameter's data block k.

[Table 1] List of communication flags based on HS link number (HS link No. 1 ~ 12)

Appendix

Notes

HS link No.	L area address	Remarks
2	L000500~L00099F	Compared with HS link of 1 in [Table 1], other HS link station number's flag address will be simply calculated as follows; * Calculation formula: $\text{L area address} = \text{L000000} + 500 \times (\text{HS link No.} - 1)$ In order to use HS link flag for program and monitoring, use the flag map registered in XG5000 for convenient application.
3	L001000~L00149F	
4	L001500~L00199F	
5	L002000~L00249F	
6	L002500~L00299F	
7	L003000~L00349F	
8	L003500~L00399F	
9	L004000~L00449F	
10	L004500~L00499F	
11	L005000~L00549F	

Example) K as a block number is displayed through 8 words by 16 for 1 word for the information of 128 blocks from 000 to 127.

For example, block information of 16~31, 32~47, 48~63, 64~79, 80~95, 96~111, 112~127 will be displayed in L00011, L00012, L00013, L00014, L00015, L00016, L00017 from block 0 to block 15 for mode information (_HS1_MOD). Thus, the mode information of the block No. 55 will be displayed in L000137.

A.3 External Dimensions

Unit: mm

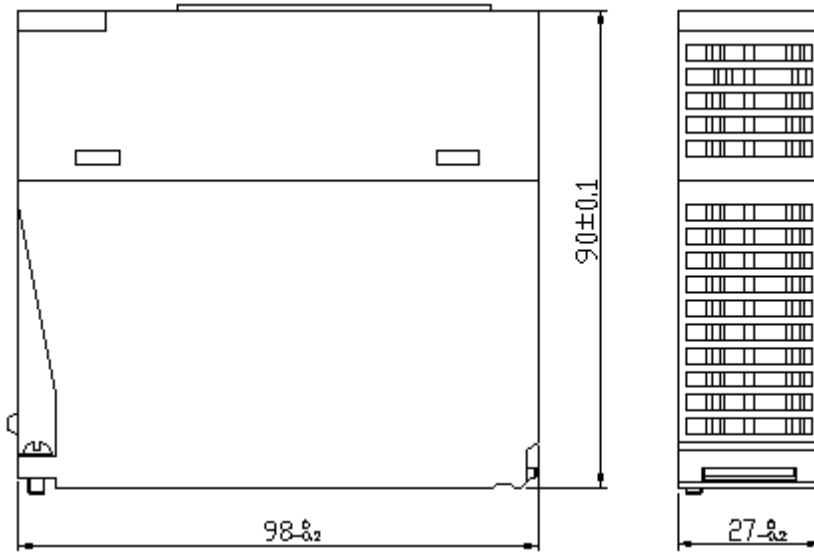

Warranty

- 1. Terms of warranty
LSIS provides an 18-month warranty starting from the date of production.

- 2. Range of warranty
For problems within the terms of the warranty, LSIS will replace the entire PLC or repair the defective parts free of charge except for the following cases.
 - (1) Problems caused by improper conditions, environment or treatment.
 - (2) Problems caused by external devices.
 - (3) Problems caused by the user remodeling or repairing the PLC.
 - (4) Problems caused by improper use of the product.
 - (5) Problems caused by circumstances where the expectations exceed that of the science and technology level when LSIS produced the product.
 - (6) Problems caused by natural disaster.

- 3. This warranty is limited to the PLC itself only. It is not valid for the system which the PLC is attached to.

Environmental Policy

LSIS Co., Ltd supports and observes the environmental policy as below.

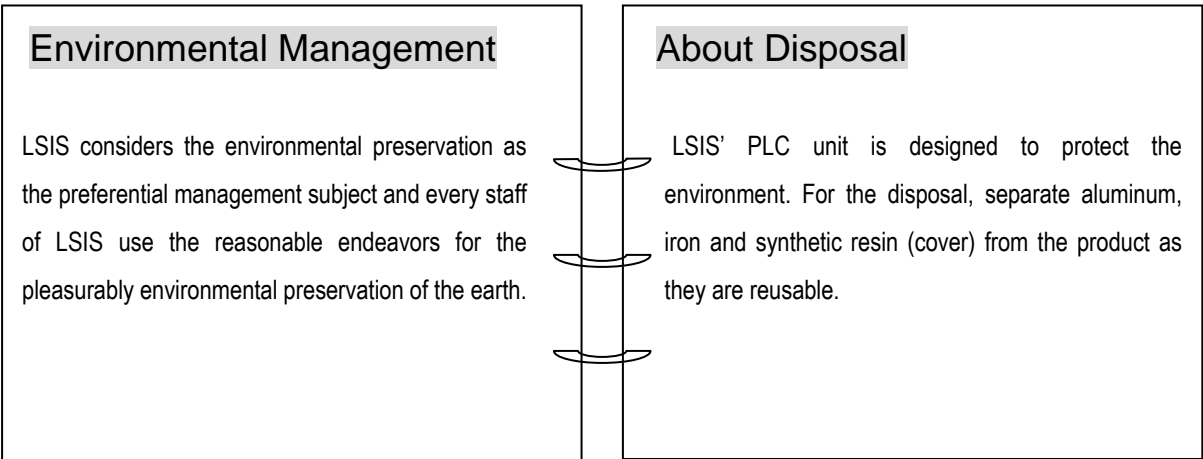



LSIS values every single customers.
Quality and service come first at LSIS.
Always at your service, standing for our customers.

<http://eng.lsis.biz>

LSIS

10310000637

■ **HEAD OFFICE**

LS tower, Hogye-dong, Dongan-gu, Anyang-si, Gyeonggi-do 1026-6,
 Korea <http://eng.lsis.biz>
 Tel : (82-2)2034-4870/Fax : 82-2-2034-4648 e-mail : cshwang@lsis.biz

■ **LSIS Tokyo Office _ Tokyo, Japan**

Address: 16FL. Higashi-Kan. Akasaka Twin Tower 17-22,
 Akasaka.Monato-ku Tokyo 107-8470. Japan
 Tel : 81-3-3582-9128/Fax : 81-3-3582-2667 e-mail : jschuna@lsis.biz

■ **LSIS (ME) FZE _ Dubai, U.A.E.**

Address : Jafza View Tower Lob 19, Room 205 Along Sheikh Zayed
 Road Jebel Aali Free Zone Dubai, United Arab Emirates
 Tel : 971-4-886-5360/Fax : 971-4-886-5361 e-mail : jungvongl@lsis.biz

■ **LSIS Shanghai Office _ Shanghai, China**

Address : Room E-G. 12FL Hiamin Empire Plaza. No.726. West.
 Yan'an Road Shanghai 200050. P.R. China e-mail : liyong@lsis.com.cn
 Tel : 86-21-5237-9977(609)/Fax : 89-21-5237-7189

■ **LSIS Beijing Office _ Beijing, China**

Address : B-Tower 17FL. Beijing Global Trade Center B/D. No. 36.
 East BeisanHuan-Road. DongCheng-District. Beijing 100013. P.R. China
 Tel : 86-10-5825-6027(666)/Fax : 86-10-5825-6028 e-mail : xunmj@lsis.com.cn

■ **LSIS Guangzhou Office _ Guangzhou, China**

Address : Room 1403.14FL. New Poly Tower.
 2 Zhongshan Liu Road.Guangzhou.P.R China
 Tel : 86-20-8328-6754/Fax : 86-20-8326-6287 e-mail : chenxs@lsis.com.cn

■ **LSIS Chengdu Office _ Chengdu, China**

Address : 12FL. Guodong Buiding. No.52 Jindun
 Road Chengdu.610041. P.R. China
 Tel : 86-28-8612-9151(9226)/Fax : 86-28-8612-9236 e-mail : comysb@lsis.biz

■ **LSIS Qingdao Office _ Qingdao, China**

Address : YinHe Bldg. 402 Room No. 2P Shandong Road,
 Qingdao-City,Shandong-province 266071, P.R. China
 Tel : 86-532-8501-6068/Fax : 86-532-8501-6057 e-mail : wangqzv@lsis.com.cn

■ **LSIS Europe B.V. , Netherlands**

Address : 1st. Floor, Tupolevlaan 48, 1119NZ, Schiphol-Rijk, The Netherlands
 Tel : +31 (0)20 654 1420/Fax : +31 (0)20 654 1429 e-mail : junshickp@lsis.biz

■ **Wuxi LSIS Co., Ltd _ Wuxi, China**

Address : 102-A. National High & New Tech Industrial Development Area.
 Wuxi. Jiangsu. 214028. P.R. China
 Tel : 86-510-8534-6666/Fax : 86-510-8534-4078 e-mail : caidx@lsis.com.cn

■ **Dalian LSIS Co., Ltd. _ Dalian, China**

Address : No. 15. Liaohexi 3-Road. Economic and Technical Development zone.
 Dalian 116600. China
 Tel : 86-411-273-7777/Fax : 86-411-8730-7560 e-mail : cuibx@lsis.com.cn

※ LSIS constantly endeavors to improve its product so that
 information in this manual is subject to change without notice.

© LSIS Co., Ltd 2011 All Rights Reserved.

2011.5