

# USER MANUAL

## Z-SG2 / Z-SG2-L

DIGITAL LOAD CELL CONVERTER WITH 24 BIT ADC



SENECA S.r.l.

Via Austria 26 – 35127 – Z.I. - PADOVA (PD) - ITALY  
Tel. +39.049.8705355 – 8705355 Fax +39 049.8706287

[www.seneca.it](http://www.seneca.it)

ORIGINAL INSTRUCTIONS

## Introduction

The content of this documentation refers to products and technologies described in it.

All technical data contained in the document may be changed without notice.

The content of this documentation is subject to periodic review.

To use the product safely and effectively, read the following instructions carefully before use.

The product must be used only for the use for which it was designed and manufactured: any other use is under the full responsibility of the user.

Installation, programming and set-up are allowed only to authorized, physically and intellectually suitable operators.

Set-up must be performed only after correct installation and the user must follow all the operations described in the installation manual carefully.

Seneca is not responsible for failures, breakages and accidents caused by ignorance or failure to apply the stated requirements.

Seneca is not responsible for any unauthorized modifications.

Seneca reserves the right to modify the device, for any commercial or construction requirement, without the obligation to promptly update the reference manuals.

No liability for the contents of this document can be accepted.

Use the concepts, examples and other content at your own risk.

There may be errors and inaccuracies in this document that could damage your system, so proceed with caution, the author(s) will not take responsibility for it.

Technical specifications are subject to change without notice.

### CONTACT US

Technical support	<a href="mailto:support@seneca.it">support@seneca.it</a>
Product information	<a href="mailto:commerciale@seneca.it">commerciale@seneca.it</a>

This document is the property of SENECA srl.  
Copies and reproduction are prohibited unless authorised.

## Document revisions

DATE	REVISION	NOTES	AUTHOR
18/07/2019	1.0.0.0	First revision	MM
16/09/2019	1.0.0.1	Added info for bootloader mode Updated info for the USB port Added a note for the Auto Resolution Added A Resolution Warning	MM
26/11/2019	1.0.0.2	Fix Status register	MM
18/05/2020	1.0.0.4	Added DIP 1 and 2 (SW3) SW2 not used	MM
08/06/2020	1.0.0.5	Added info on chapters 10.2.9.4 and 10.2.9.5 Fix "Z-SG2 name"	MM
12/10/2020	6	Correct power supply terminals page 9	AZ
16/12/2021	7	Corretto il numero dei morsetti dell'alimentazione	AZ
13/03/2023	8	Fix Led FAIL	MM

**TABLE OF CONTENTS**

- 1. INTRODUCTION.....7**
- 1.1. DESCRIPTION.....7
- 1.2. TECHNICAL SPECIFICATIONS .....8
- 2. LED SIGNALS .....9**
- 2.1. Z-SG2 / Z-SG2-L LED .....9
- 3. INSULATION .....9**
- 4. POWER SUPPLY .....10**
- 5. LOAD CELL CONNECTION.....11**
- 5.1. 4 OR 6-WIRE LOAD CELL CONNECTION.....11
- 6. CHECKING THE LOAD CELL OPERATION .....12**
- 6.1. CHECKING CABLES WITH A DIGITAL MULTIMETER.....12
- 7. CONNECTION OF MORE LOAD CELLS IN PARALLEL .....12**
- 7.1. TRIMMING 4-WIRE LOAD CELLS .....14
- 8. DIGITAL OUTPUT / INPUT CONNECTIONS .....15**
- 8.1.1. ANALOGUE OUTPUT CONNECTIONS (Z-SG2 ONLY) .....15
- 8.2. RS485 PORT CONNECTIONS.....16
- 9. CONFIGURATION OF THE RS485 PORT BY DIP SWITCH .....18**
- 9.1. CONFIGURATION OF THE FLASH MEMORY RS485 PORT .....18
- 9.2. SETTING THE BAUD RATE OF THE RS485 PORT BY DIP SWITCH .....19
- 9.3. SETTING THE MODBUS STATION ADDRESS OF THE RS485 PORT BY DIP SWITCH .....20
- 9.4. DISCONNECT THE GND FROM THE RS485 BY DIP 1 OF SW3.....21
- 9.5. SETTING THE R-C TERMINATOR BY DIP 2 OF SW3 .....21
- 10. COMPLETE CONFIGURATION WITH EASY SETUP .....21**
- 10.1. EASY SETUP MENU .....21
- 10.2. CREATING A PROJECT .....23
- 10.2.1. OPERATING MODE.....23
- 10.2.1.1. FACTORY CALIBRATION .....23
- 10.2.1.2. CALIBRATION WITH SAMPLE WEIGHT .....24
- 10.2.2. TYPE OF MEASUREMENT .....24
- 10.2.2.1. COMPRESSION ONLY (SCALES) .....24
- 10.2.2.2. COMPRESSION AND TRACTION.....24
- 10.2.3. UNIT OF MEASUREMENT .....24
- 10.2.4. CELL SENSITIVITY.....24

10.2.5.	CELL FULL SCALE .....	24
10.2.6.	SAMPLE WEIGHT.....	24
10.2.7.	NOISE FILTER .....	24
10.2.8.	FILTER LEVEL .....	25
10.2.9.	ADVANCED FILTERING .....	25
10.2.9.1.	NUMBER OF SAMPLES OF THE MOVING AVERAGE .....	25
10.2.9.2.	ADC CHOPPING.....	25
10.2.9.3.	ADC SPEED.....	25
10.2.9.4.	NOISE VARIATION IN ADC POINTS .....	26
10.2.9.5.	FILTER RESPONSE SPEED .....	26
10.2.10.	NET WEIGHING RESOLUTION .....	26
10.2.10.1.	MAXIMUM RESOLUTION .....	26
10.2.10.1.	MANUAL.....	26
10.2.10.2.	AUTOMATIC RESOLUTION .....	26
10.2.11.	DIGITAL INPUT/OUTPUT SELECTION.....	27
10.2.12.	DIGITAL INPUT CONFIGURATION.....	27
10.2.12.1.	ACQUIRES THE TARE .....	27
10.2.12.2.	EXTERNAL DIGITAL INPUT.....	27
10.2.13.	DIGITAL OUTPUT OPERATION MODE.....	27
10.2.13.1.	CELL FULL SCALE .....	27
10.2.13.2.	EXCEEDING THE THRESHOLD AND STABLE WEIGHING .....	27
10.2.13.3.	STABLE WEIGHING .....	28
10.2.13.4.	MODBUS CONTROLLABLE .....	28
10.2.13.5.	EXCEEDED THRESHOLD WITH HYSTERESIS (ALARM) .....	28
10.2.14.	STABLE WEIGHING CONDITION .....	28
10.2.14.1.	DELTA WEIGHT .....	29
10.2.14.2.	DELTA TIME.....	29
10.2.15.	NET WEIGHING ALARM .....	29
10.2.16.	HYSTERESIS.....	29
10.2.17.	ANALOGUE OUTPUT TYPE .....	29
10.2.17.1.	VOLTAGE.....	29
10.2.17.2.	CURRENT .....	29
10.2.18.	ANALOGUE OUTPUT CONFIGURATION.....	30
10.2.19.	STATION ADDRESS.....	30
10.2.20.	BAUD RATE .....	30
10.2.21.	PARITY.....	30
10.2.22.	DELAY IN REPLYING .....	30
10.2.23.	SAMPLE WEIGHT.....	30
10.2.24.	AUTOMATIC TARE TRACKER.....	30
10.2.24.1.	TARE TRACKER .....	30
10.2.24.2.	ADC VALUE .....	30
10.2.25.	FLOATING POINT REPRESENTATION OF THE MEASUREMENTS .....	31
10.2.25.1.	FIRST PART H THEN L .....	31
10.2.25.2.	FIRST PART I THEN h .....	31
<b>10.3.</b>	<b>DEVICE TEST.....</b>	<b>31</b>
10.3.1.	THE DATA LOGGER .....	32
<b>11.</b>	<b>CALIBRATION OF THE LOAD CELL WITH THE EASY SETUP SOFTWARE .....</b>	<b>32</b>
11.1.	FACTORY CELL CALIBRATION.....	32
11.2.	FACTORY CALIBRATION WITH TARE ACQUISITION FROM THE FIELD .....	33

11.3.	FACTORY CALIBRATION WITH MANUAL TARE ACQUISITION .....	33
11.4.	CELL CALIBRATION WITH A SAMPLE WEIGHT .....	34
<b>12.</b>	<b>USB PORT .....</b>	<b>35</b>
12.1.	DRIVERS FOR WINDOWS SYSTEMS .....	36
12.2.	DRIVERS FOR LINUX SYSTEMS.....	36
<b>13.</b>	<b>FIRMWARE UPDATE.....</b>	<b>36</b>
<b>14.</b>	<b>LOAD CELL CALIBRATION WITH MODBUS REGISTERS .....</b>	<b>37</b>
14.1.	CALIBRATION PROCEDURE WITH AN EXTERNAL DEVICE (FACTORY CALIBRATION WITH TARE ACQUIRED FROM THE FIELD).....	37
14.2.	CALIBRATION PROCEDURE WITH AN EXTERNAL DEVICE (FACTORY CALIBRATION WITH MANUALLY INSERTED TARE) 37	37
14.3.	CALIBRATION PROCEDURE WITH AN EXTERNAL DEVICE (CALIBRATION WITH SAMPLE WEIGHT).....	37
<b>15.</b>	<b>MODBUS RTU SLAVE COMMUNICATION PROTOCOL .....</b>	<b>38</b>
15.1.	SUPPORTED MODBUS FUNCTION CODES.....	38
<b>16.</b>	<b>MODBUS REGISTER TABLE .....</b>	<b>39</b>
16.1.	NUMBERING OF "0-BASED" OR "1-BASED" MODBUS ADDRESSES .....	39
16.1.1.	NUMBERING OF MODBUS ADDRESSES WITH "0-BASED" CONVENTION .....	40
16.1.2.	NUMBERING OF MODBUS ADDRESSES WITH "1 BASED" CONVENTION (STANDARD).....	40
16.2.	BIT CONVENTION WITHIN A MODBUS HOLDING REGISTER .....	41
16.3.	MSB and LSB BYTE CONVENTION WITHIN A MODBUS HOLDING REGISTER.....	41
16.4.	REPRESENTATION OF A 32-BIT VALUE IN TWO CONSECUTIVE MODBUS HOLDING REGISTERS .....	42
16.5.	TYPE OF 32-BIT FLOATING POINT DATA (IEEE 754) .....	42
16.6.	Z-SG2 / Z-SG2-L: MODBUS 4X HOLDING REGISTERS TABLE (FUNCTION CODE 3) .....	44

## 1. INTRODUCTION

### **ATTENTION!**

This user manual extends the information from the installation manual to the configuration of the device. Use the installation manual for more information.

### **ATTENTION!**

In any case, SENECA s.r.l. or its suppliers will not be responsible for the loss of data/revenue or consequential or incidental damages due to negligence or bad/improper management of the device, even if SENECA is well aware of these possible damages.

SENECA, its subsidiaries, affiliates, group companies, suppliers and distributors do not guarantee that the functions fully meet the customer's expectations or that the device, firmware and software should have no errors or operate continuously.

### 1.1. DESCRIPTION

Z-SG2 is a load cell converter (strain gauge). The measurement, carried out with the 4 or 6-wire technique, is available via the MODBUS-RTU serial protocol or via the fully configurable analogue output. The device is equipped with a new noise filter specifically developed to obtain a rapid response time. The device is fully configurable via the USB or RS485 ports using the Easy Setup configuration software. Compared to its predecessor, it offers a new anti-noise filter and numerous new features, dramatically increasing product performance.

Model	Description	Communication protocol
Z-SG2	Strain Gauge converter with digital input/output and analogue output	Modbus RTU Slave
Z-SG2-L	Strain Gauge converter with digital input/output	Modbus RTU Slave

**1.2. TECHNICAL SPECIFICATIONS**

<b>TECHNICAL SPECIFICATIONS</b>	
<b>Analogue/digital converter</b>	24 Bit > of 16777000 points
<b>Type of measurement</b>	Unipolar ratiometric (compression only) or bipolar ratiometric (compression and traction)
<b>Noise digital filter</b>	New advanced digital filter with configurable response time from 16ms to about 2s. Filter advanced configuration possibility.
<b>Analogue output response time</b>	About 5ms.
<b>Modbus port (RS485) response time</b>	About 6ms.
<b>Net weight resolution</b>	Configurable, factory-set on 10000 points (automatic).
<b>Isolated analogue output resolution</b>	10000 points
<b>Operating mode</b>	Calibration with sample weight (in the field) or without calibration (factory calibration).
<b>Isolated digital input/output</b>	Yes, configurable between input/output.
<b>USB port</b>	Yes, on the front for the configuration, calibration, register reading. Drivers Virtual com port for Windows <sup>™</sup> , Linux, MAC OS, Windows CE
<b>Configuration and calibration software</b>	Easy Setup, free. For Windows operating systems.
<b>Isolated digital input functions</b>	Configurable between tare reset or external digital input.
<b>Isolated digital output functions</b>	Configurable in alarm mode: <ul style="list-style-type: none"> <li>- Cell bottom scale exceeded</li> <li>- Threshold and stable weighing exceeded</li> <li>- Stable weighing</li> <li>- Generic output controlled by Modbus</li> <li>- Threshold exceeded with hysteresis</li> </ul>
<b>Isolated analogue output (only Z-SG2)</b>	Voltage/Current configurable. Fully configurable on the 0-10V / 0-20mA range.
<b>Firmware update</b>	Yes for the addition of new functions.
<b>Sensitivity</b>	From +-1 mV/V to +-64 mV/V
<b>“Stable weighing” function</b>	Yes, configurable
<b>Automatic tare tracker function</b>	Yes, configurable
<b>Piece counting function</b>	Yes, configurable
<b>“Manual tare” function</b>	Yes, configurable. It does not need to acquire the tare value from the field but it can be entered manually.



RS485 port baud rate	From 2400 to 115200 bit/s configurable
Parity, Delay in replying	Configurable
USB / RS485 port protocol	Modbus RTU Slave

## 2. LED SIGNALS

### 2.1. Z-SG2 / Z-SG2-L LED

LED SIGNALS ON THE Z-SG2 / Z-SG2-L FRONT		
LED	STATUS	LED MEANING
PWR	ON	Device powered
PWR	OFF	Device OFF
ERR	ON	Strain Gauge Out of range
RX	FLASHING	Data receipt on RS485 port
TX	FLASHING	Data sending on RS485 port
TX	ON	Check RS485 port connection

## 3. INSULATION

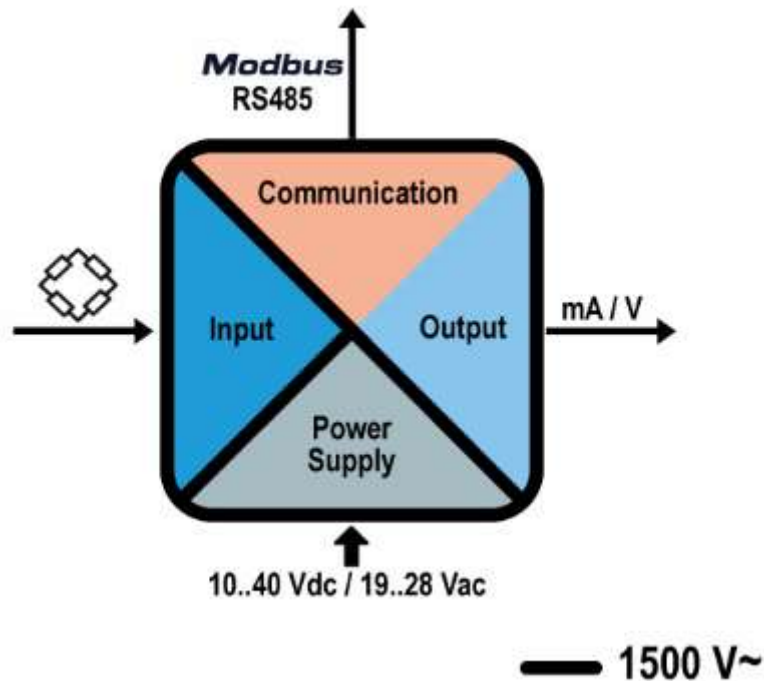

#### 4. POWER SUPPLY

### ATTENTION!

*The upper power supply limits must not be exceeded, as this might cause serious damage to the module*

Switch the module off before connecting inputs and outputs.

To meet the electromagnetic immunity requirements:

- use shielded signal cables;
- connect the shield to a preferential instrumentation earth system;
- separate shielded cables from other cables used for power installations (transformers, inverters, motors, induction ovens, etc...)

The power supply must be connected to terminals 2 and 3.

The supply voltage must be between:

10 and 40Vdc (indifferent polarity), or between 19 and 28 Vac.

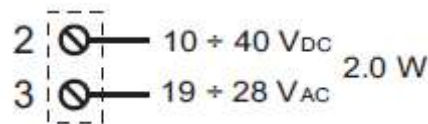

19 – 28 Vac 50 – 60 Hz

10 – 40 Vdc

Maximum absorption 2 W

If the ZPCDIN accessory is used, it is not necessary to wire the power supply (nor the RS485 port) as it is present in the IDC10 connector:

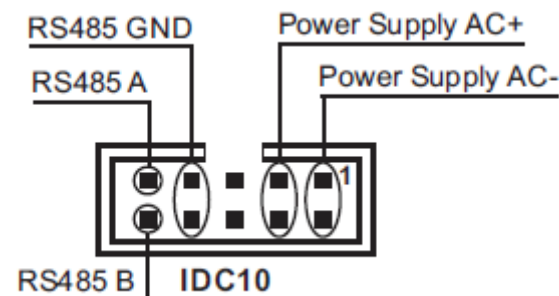

## 5. LOAD CELL CONNECTION

It is possible to connect the converter to the load cell in 4- or 6-wire mode. 6-wire measurement is preferable for measurement accuracy.

The load cell power supply is provided directly by Z-SG2.

### 5.1. 4 OR 6-WIRE LOAD CELL CONNECTION

A load cell can have a four-wire or six-wire cable. In addition to having the +/- excitation and +/- signal lines a six-wire cable also has the +/- sense lines. It is a common misconception to think that the only difference between 4- or 6-wire load cells is the possibility of the latter to measure the actual voltage at the load cell. A load cell is compensated to work within specifications in a certain temperature range (usually -10 - +40°C). Since the cable resistance depends on the temperature, the response of the cable to temperature changes must be eliminated. The 4-wire cable is part of the load cell temperature compensation system. The 4-wire load cell is calibrated and compensated with a certain amount of cable connected. For this reason, never cut the cable of a 4-wire load cell. The cable of a 6-wire cell, on the other hand, is not part of the load cell temperature compensation system. The sense lines are connected to the sense terminals of the indicator/meter, to measure and adjust the actual voltage of the load cell. The indicator/meter corrects the output voltage or its amplifier to compensate for the change in resistance in the cable. The advantage of using this "active" system is the possibility of cutting (or extending) the 6-wire load cell cable to any length. It must be considered that a 6-wire load cell will not reach the performance declared in the specifications if the sense lines are not used.

The figures show the two possible connections:

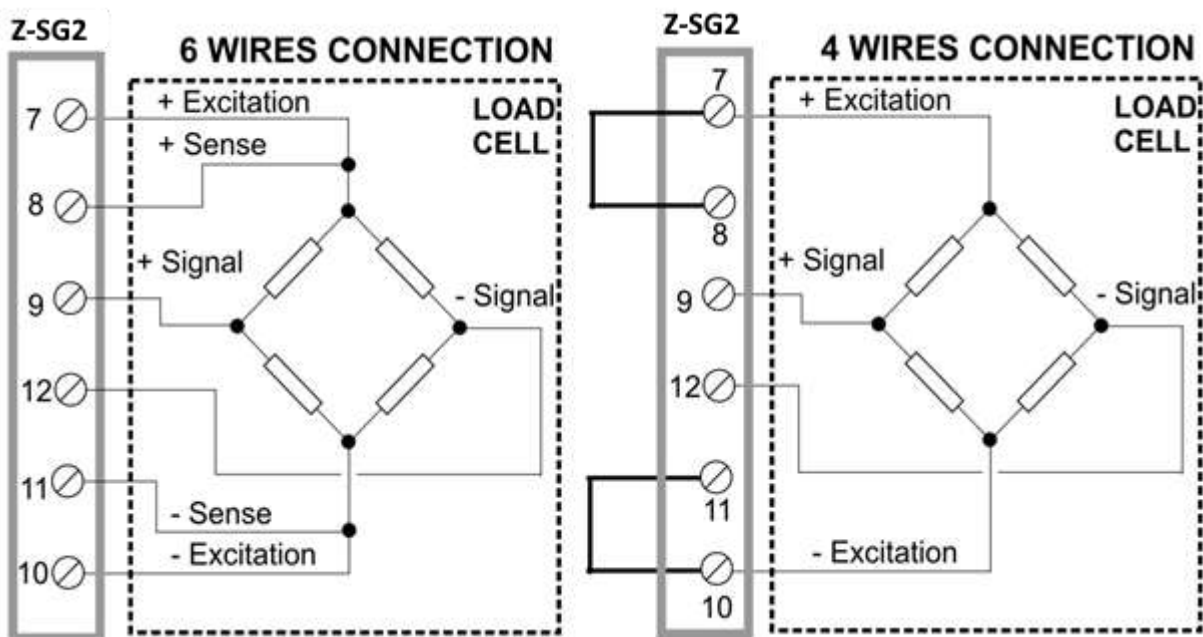

LOAD CELL CONNECTION		
SIGNAL	TERMINAL No.	MEANING
+Excitation	7	Cell supply (+)
+Sense	8	Reading of the supply to the cell (+)
+Signal	9	Load cell signal (+)
- Signal	12	Load cell signal (-)
- Sense	11	Reading of the supply to the cell (-)
- Excitation	10	Cell supply (-)

## 6. CHECKING THE LOAD CELL OPERATION

Before starting the configuration of the device it is necessary to verify the correctness of the wiring and the integrity of the load cell.

### 6.1. CHECKING CABLES WITH A DIGITAL MULTIMETER

First you need to check with the load cell manual that there are about 5V DC between the +Excitation and – Excitation cables. If the cell has 6 wires check that the same voltage is also measured between +Sense and – Sense.

Now leave the cell at rest (without the tare) and check that the voltage between the +Signal and –Signal cables is around 0 V.

Now unbalance the cell by applying a compression force, checking that the signal increases until it reaches the full scale (if possible) where the measurement will be approximately:

5\* (cell sensitivity) mV.

For example, if the declared cell sensitivity is 2 mV/V,  $5 * 2 = 10$  mV must be obtained.

In the case of bipolar measurement only (compression/traction) it is necessary to completely unbalance the cell even in traction, in this case the same value must be measured between the +Signal and –Signal cables but with the negative sign:

-5\* (cell sensitivity) mV.

## 7. CONNECTION OF MORE LOAD CELLS IN PARALLEL

It is possible to connect up to a maximum of 8 load cells (and in any case without ever falling below the minimum 87 Ohms). It is therefore possible to connect:

<i>NUMBER OF LOAD CELLS IN PARALLEL</i>	
<i>IMPEDANCE OF THE STATED LOAD CELL [Ohm]</i>	<i>MAXIMUM NUMBER OF CONNECTABLE CELLS IN PARALLEL</i>
350	4
1000	8

For the connection of 4 load cells Seneca recommends using the SG-EQ4 product.

To connect 2 or more 4-wire cells in parallel with the SG-EQ4 junction box, use the following diagram:

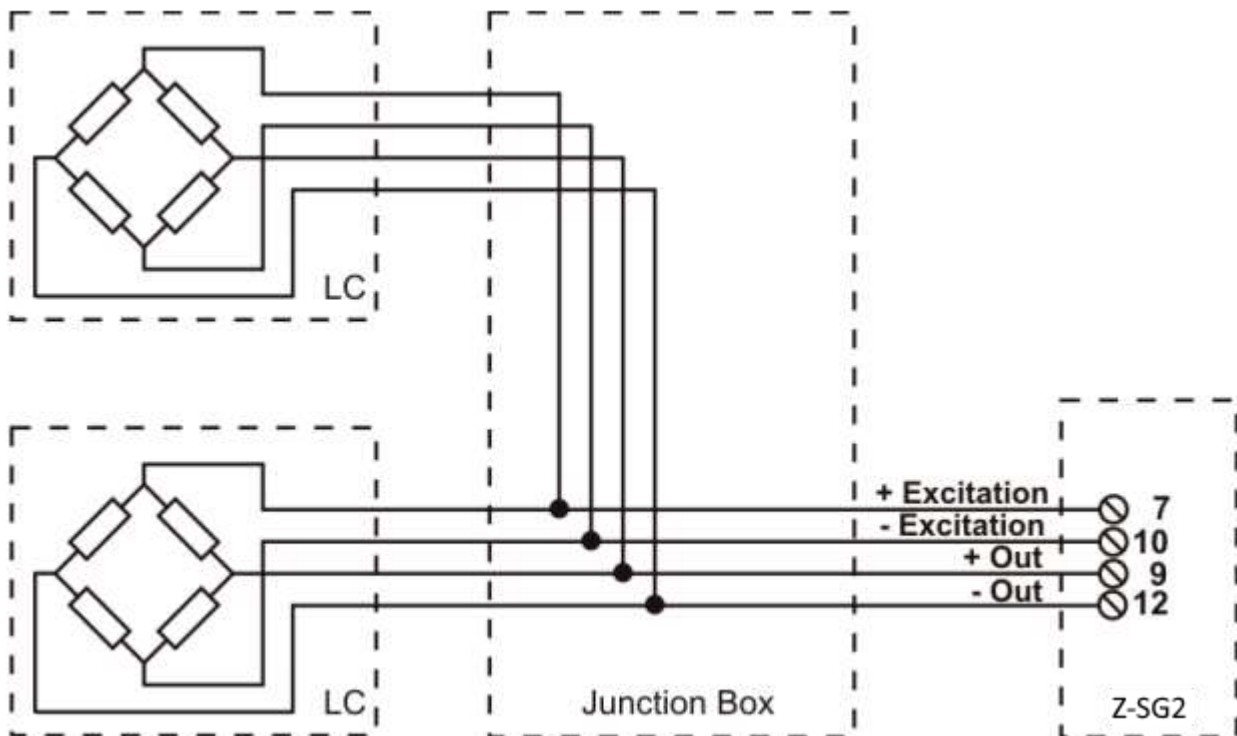

To connect 2 or more 6-wire cells in parallel with the SG-EQ4 junction box use the following diagram:

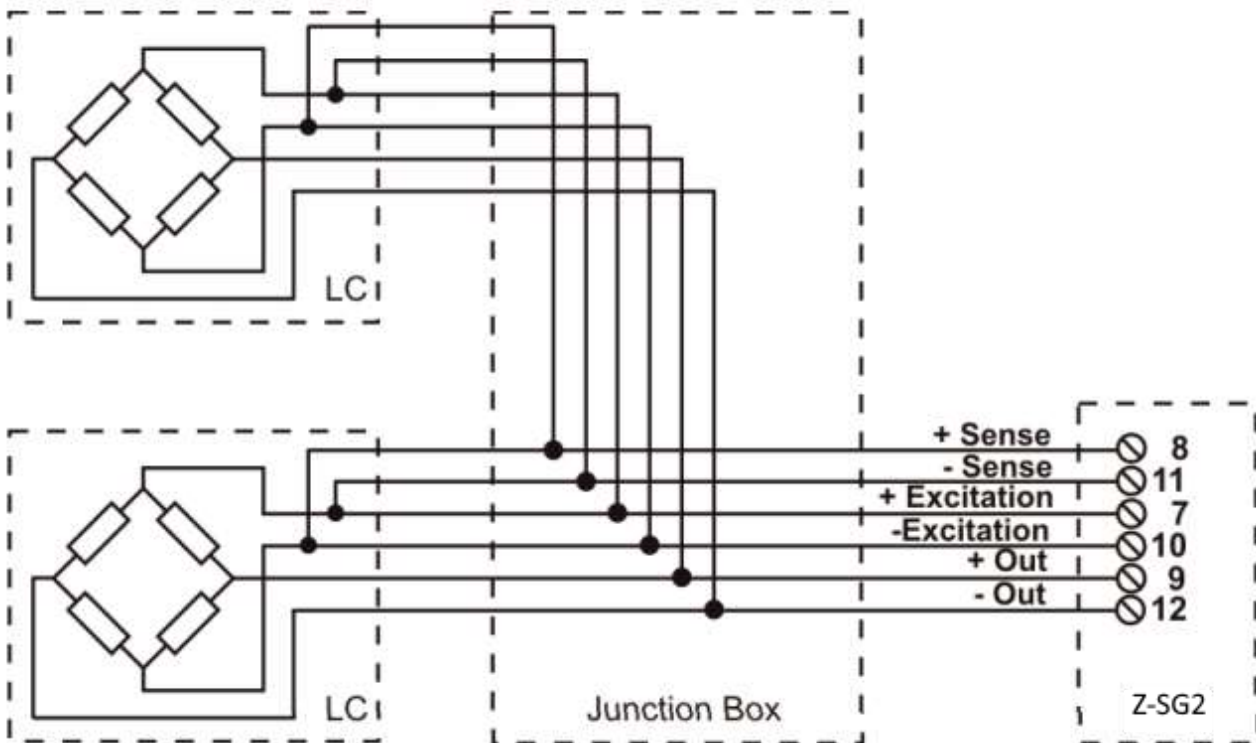

For more details, refer to the SG-EQ4 Junction Box accessory manual.

### 7.1. TRIMMING 4-WIRE LOAD CELLS

The figure below shows a diagram of three trimmed load cells.

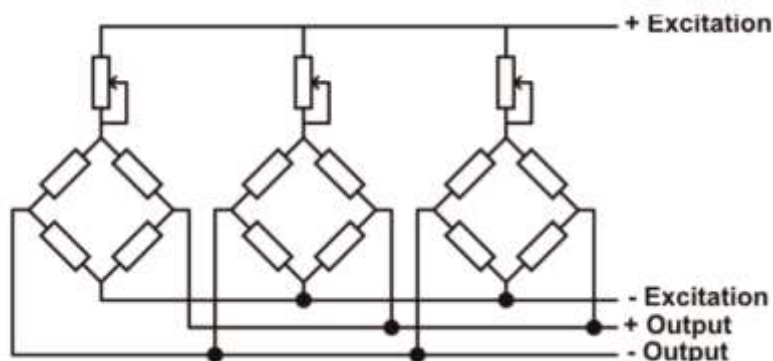

A variable resistor, independent of the temperature, or a typically 20 Ω potentiometer is inserted in the +Excitation cable of each load cell. There are two ways to trim the load cells: The first method is to adjust the potentiometers by trial, shifting the calibration weights from one corner to another. All the potentiometers must be adjusted so as to set the maximum sensitivity for each cell, turning them all completely clockwise. Then, once the angle with the lowest output is located, act on the trimmers of the other cells until obtaining the same minimum output value. This method can be very long, especially for large scales where the use of test weights

on the corners is not very practical. In these cases the second, more suitable method is to "pre-trim" the potentiometers using a precision voltmeter (at least 4 1/2 digits). You can use the following procedure:

- 1) Determine the exact mV/V ratio of each load cell, shown in the calibration certificate of the cell itself.
- 2) Determine the exact excitation voltage provided by the indicator/meter (for example Z-SG), measuring this voltage with the voltmeter (for example 10.05 V).
- 3) Multiply the lowest mV/V value found (point 1) by the excitation voltage (point 2).
- 4) Divide the trimming factor calculated in point 3 by the mV/V value of the other load cells.
- 5) Measure and adjust the excitation voltage of the other three load cells using the respective potentiometer. Check the results and make a final adjustment by moving a test load from corner to corner.

## 8. DIGITAL OUTPUT / INPUT CONNECTIONS

The device can be configured with a digital input or output.

The digital input can be configured to reset the tare if it is active for more than 3 seconds.

The digital output can be linked to a series of events (for example alarm on threshold, stable weighing etc ...).

In the case of configuration as a digital input or as a digital output, the connection diagram is as follows:

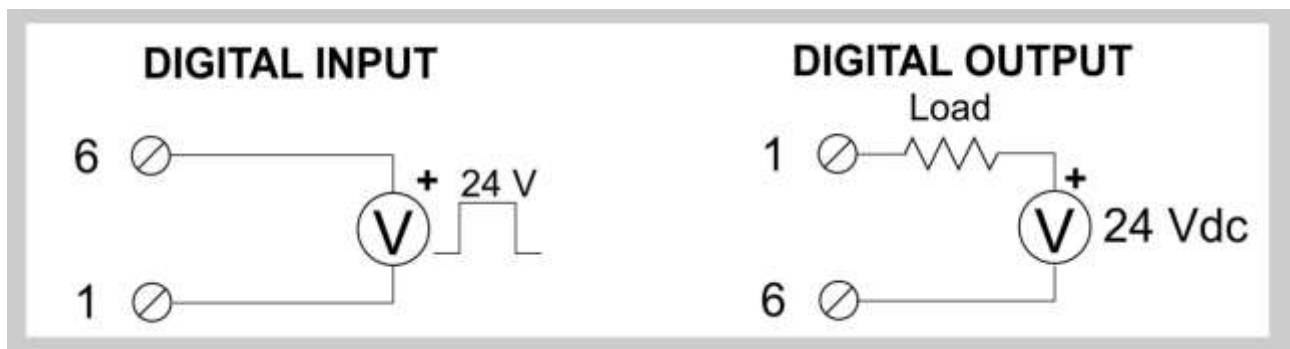

### 8.1.1. ANALOGUE OUTPUT CONNECTIONS (Z-SG2 ONLY)

The Z-SG2 device has an analogue output that can be configured for either voltage or current.

The operating ranges are 0-10V for the voltage output, 0-20 mA for the current output.

It is possible to freely configure the output in the entire range.

The wiring diagrams are:

Analogue voltage output:



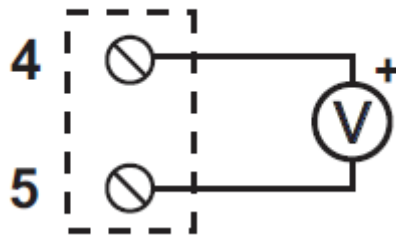

Analogue current output:

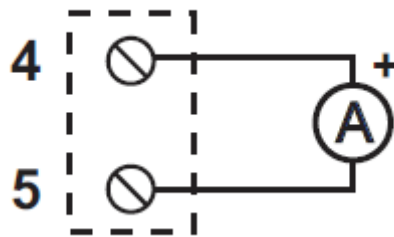

## 8.2. RS485 PORT CONNECTIONS

The device has an RS485 serial port to be connected to the Z-PC-DINAL accessory and therefore directly connected to the Seneca Z-PC range of devices:

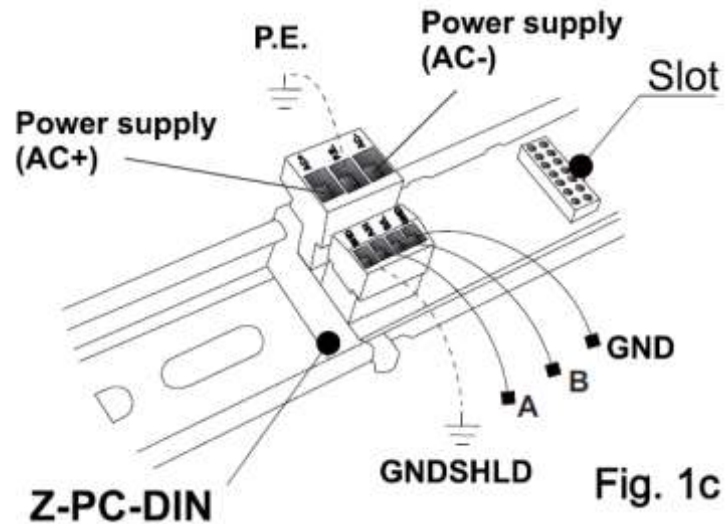

Find below the pins for connector IDC10:



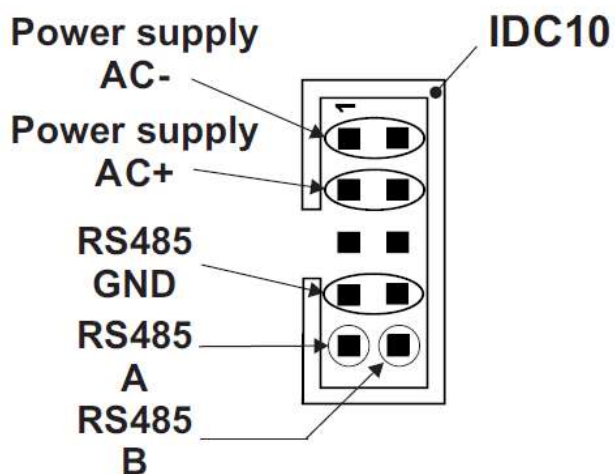

**Fig. 1d**

The protocol available through the RS485 port is Modbus RTU Slave.

## 9. CONFIGURATION OF THE RS485 PORT BY DIP SWITCH

The SW1 dip switch is used to configure the parameters related to the RS485 communication port.

DIP switches 1 and 2 are used for the baud rate of the RS485 port

DIP switches 3 to 8 are used for the Modbus station address of the RS485 port



### ATTENTION!

The configuration via dip switch is active only after a restart!



### ATTENTION!

The configuration via dip switch has priority over the one saved in flash, if you need to use the configuration of the RS485 port sent by Easy Setup you must bring all the dip switches 1..8 to "OFF" and restart the device.

### 9.1. CONFIGURATION OF THE FLASH MEMORY RS485 PORT

If ALL the dip switches 1 ... 8 are OFF, the device uses the configuration saved in Flash (configured with the Easy Setup software) for the RS485 port.

<b>RS485 configuration</b>	<b>DIP1</b>	<b>DIP2</b>	<b>DIP3</b>	<b>DIP4</b>	<b>DIP5</b>	<b>DIP6</b>	<b>DIP7</b>	<b>DIP8</b>
FROM FLASH	OFF	OFF	OFF	OFF	OFF	OFF	OFF	OFF

## 9.2. SETTING THE BAUD RATE OF THE RS485 PORT BY DIP SWITCH

Dip switches 1 and 2 configure the baud rate.

<i>Baud Rate</i>	<i>DIP1</i>	<i>DIP2</i>
9600	OFF	OFF
19200	OFF	ON
38400	ON	OFF
57600	ON	ON



### **ATTENTION !**

The parity bit and other baud rates can only be configured via the Easy Setup software.  
Setting the dip switches, parity will always be "No" and stop bits always at 1.

**9.3. SETTING THE MODBUS STATION ADDRESS OF THE RS485 PORT BY DIP SWITCH**

Dip switches 3 to 8 are used to configure the modbus station address of the RS485 port using the binary convention:

<b>Modbus Station Address</b>	<b>DIP3</b>	<b>DIP4</b>	<b>DIP5</b>	<b>DIP6</b>	<b>DIP7</b>	<b>DIP8</b>
1	OFF	OFF	OFF	OFF	OFF	ON
2	OFF	OFF	OFF	OFF	ON	OFF
3	OFF	OFF	OFF	OFF	ON	ON
4	OFF	OFF	OFF	ON	OFF	OFF
5	OFF	OFF	OFF	ON	OFF	ON
6	OFF	OFF	OFF	ON	ON	OFF
7	OFF	OFF	OFF	ON	ON	ON
8	OFF	OFF	ON	OFF	OFF	OFF
9	OFF	OFF	ON	OFF	OFF	ON
10	OFF	OFF	ON	OFF	ON	OFF
11	OFF	OFF	ON	OFF	ON	ON
12	OFF	OFF	ON	ON	OFF	OFF
13	OFF	OFF	ON	ON	OFF	ON
14	OFF	OFF	ON	ON	ON	OFF
15	OFF	OFF	ON	ON	ON	ON
...	...	...	...	...	...	...
63	ON	ON	ON	ON	ON	ON



# ATTENTION !

To set station addresses > 63 it is necessary to use the Easy Setup software.

9.4. **DISCONNECT THE GND FROM THE RS485 BY DIP 1 OF SW3**

If two or more Z-SG2s are connected on the same bus and in both of them you need to use the analog output in order to avoid malfunctions, it is necessary to disconnect the GND connection on the RS485 port by acting on DIP1 of SW3:

<b>GND RS485</b>	<b>DIP1 SW3</b>
CONNECTED	OFF
DISCONNECTED	ON

9.5. **SETTING THE R-C TERMINATOR BY DIP 2 OF SW3**

Usually it is not necessary to use a terminator on the RS485 line unless this is inserted into the bus by some other device (for example some modbus masters have a terminator that cannot be removed).

<b>Terminator</b>	<b>DIP2 SW3</b>
OFF	OFF
ON	ON

10. **COMPLETE CONFIGURATION WITH EASY SETUP**

To configure the device it is necessary to install the free "Easy Setup" software suite which can be downloaded in section Z-SG2/Z-SG2-L of the [www.seneca.it](http://www.seneca.it) website.

10.1. **EASY SETUP MENU**

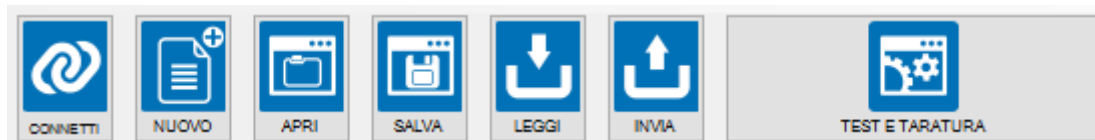

**Connect:** Allows connecting the device to the PC.

**New:** Loads the default (factory) parameters onto the current project.

**Open:** Opens a previously saved project.

**Save:** Saves the current project

**Read:** Reads the current configuration from the device

**Send:** Sends the configuration (if the dip switches ARE NOT ALL OFF the device uses the configuration of the RS485 by dip switch and NOT the one sent by the configuration)

**Test and Calibration:** Opens a new screen to read the main registers and allows you to send the commands for the calibration of the load cell to the device.

## 10.2. CREATING A PROJECT

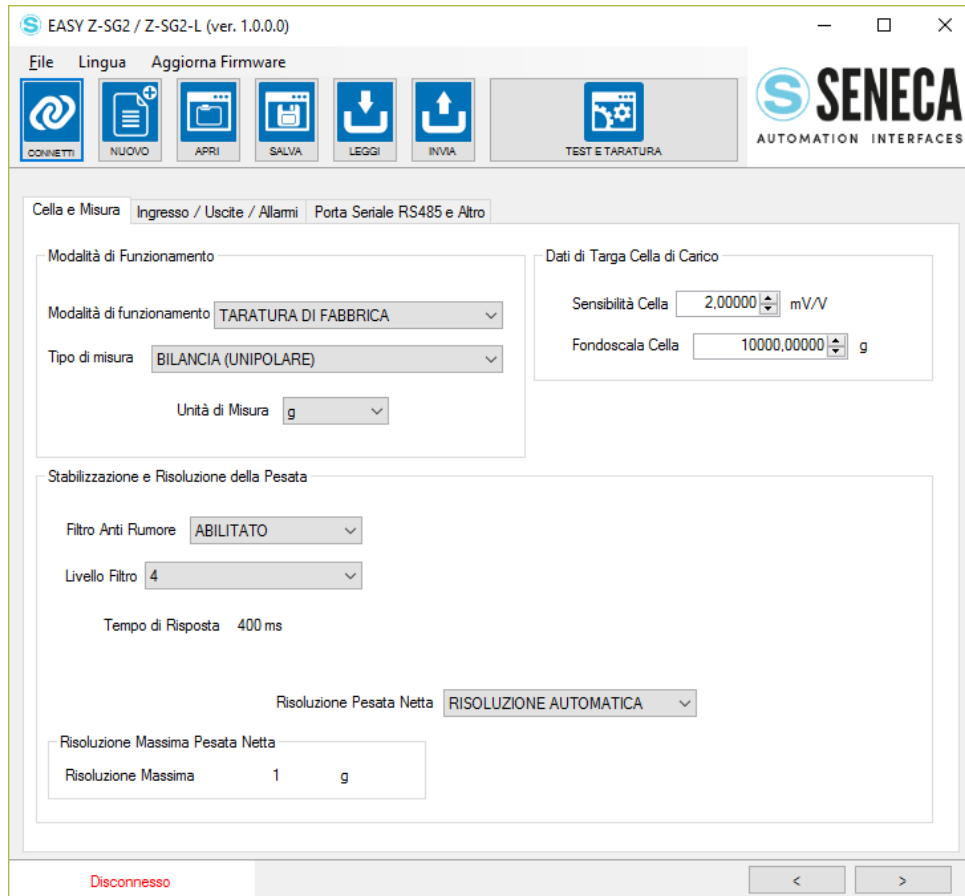

### ATTENTION!

It is necessary to set all the dip switches to OFF before sending the configuration to the device or the configuration of the RS485 port will be consistent with the dip switch settings!

### 10.2.1. OPERATING MODE

It allows to configure the basic operation of the device, can be set to factory calibration or to Calibration with Sample weight:

#### 10.2.1.1. FACTORY CALIBRATION

It is used when a load cell with declared sensitivity (cell calibration) combined with the calibration of the device's factory full scale is available.

In this mode the calibration consists only in acquiring the tare directly on the field with a direct measurement or manually entering the tare value. For more information refer to chapters 11 and 14 of the manual.

### **10.2.1.2. CALIBRATION WITH SAMPLE WEIGHT**

It is used when a sample weight is available (as far as possible towards the load cell full scale).

In this mode the calibration consists in acquiring both the tare and the sample weight directly on the field. For more information refer to chapters 11 and 14 of the manual.

### **10.2.2. TYPE OF MEASUREMENT**

It allows to configure the operation of the device between:

#### **10.2.2.1. COMPRESSION ONLY (SCALES)**

It is used when a scale is being created in which the load cell is only compressed, in this case the maximum resolution of the compression measurement is obtained.

#### **10.2.2.2. COMPRESSION AND TRACTION**

It is used when a measurement system (typically of force) is being created that can both compress and extend the load cell. In this case the direction of the force can also be decided, if compression the measurement will have the + sign, if traction it will have the - sign. A typical case of use is to link the direction of the force to the analogue output so that, for example, 4mA correspond to the maximum traction force and 20mA correspond to the maximum compression force (in this case the cell at rest will provide 12Ma).

### **10.2.3. UNIT OF MEASUREMENT**

It allows to set the weighing unit of measurement (selectable between Kg, g, t, etc. ...)

### **10.2.4. CELL SENSITIVITY**

It is the value expressed in mV/V declared by the cell (in most cells it is 2mV/V).

### **10.2.5. CELL FULL SCALE**

It is the value expressed in the selected unit of measurement declared by the cell.

### **10.2.6. SAMPLE WEIGHT**

If the mode of operation with sample weight has been chosen, it is necessary to enter the value of the sample weight that will be used in the calibration.

### **10.2.7. NOISE FILTER**

It enables or disables the noise filter for the weight measurement. The filter consists of two sections:

In the first there is an anti-noise filter based on a statistic obtained from the input, in the second there is a filter in moving average.

If the noise filter is disabled, it will still be possible to act on the moving average and on the ADC speed (see chapter 10.2.9).



10.2.8. **FILTER LEVEL**

It is possible to configure a pre-set filter level (this is a combination of the two sections described above). Depending on the level, the response time will also appear, in particular:

<b>FILTER LEVEL</b>	<b>RESPONSE TIME [ms]</b>
0	16
1	32
2	50
3	250
4	400 (default)
5	900
6	1800
ADVANCED	Dependent on the configuration

The higher the filter level the more stable (but slow) the weight measurement will be. In the "Advanced" mode it will be possible to act on the individual filter parameters (to be used only by experts or on the advice of Seneca personnel).

10.2.9. **ADVANCED FILTERING**

These parameters can only be configured by expert personnel or at the suggestion of Seneca:

**10.2.9.1. NUMBER OF SAMPLES OF THE MOVING AVERAGE**

It is the number of samples on which the moving average is calculated, the more it increases and the slower and more stable the response of the filter is (minimum 1, maximum 100).

**10.2.9.2. ADC CHOPPING**

It allows you to enable the ADC chopping feature (it decreases acquisition speed and noise and improves ADC performance).

***This mode can only be activated with the calibration with sample weight mode.***

**10.2.9.3. ADC SPEED**

It is a parameter that configures the sampling rate of the ADC.

With *ADC CHOPPING DISABLED* it can be configured from 3 (maximum speed) to 255 (minimum speed). The speed is calculated with the formula:

$$f_{ADC}[Hz] = \frac{4096}{ADC\_speed\_register}$$

So for example with the value 3 we get an ADC speed of:

$$f_{ADC} [Hz] = \frac{4096}{3} = 1365 \text{ Hz}$$

With *ADC CHOPPING ENABLED* it can be configured from 13 (maximum speed) to 255 (minimum speed). The speed is calculated with the formula:

$$f_{ADC \text{ CHOP}} [Hz] = \frac{4096}{3 * ADC\_speed\_register}$$

So for example with the value 13 we get an ADC speed of:

$$f_{ADC} [Hz] = \frac{4096}{13 * 3} = 105 \text{ Hz}$$

#### **10.2.9.4. NOISE VARIATION IN ADC POINTS**

It represents the variation in ADC points due to noise alone (represents the measurement uncertainty due to noise) or how much we expect it to vary (the unit of measurement is in rough ADC points).

#### **10.2.9.5. FILTER RESPONSE SPEED**

It represents a parameter related to the filter response speed, it can vary from 0.001 (slowest response) to 1 (fastest response). Represents the variance of the process.

### **10.2.10. NET WEIGHING RESOLUTION**

It is the resolution with which the net weight value is represented.

#### **10.2.10.1. MAXIMUM RESOLUTION**

It will represent the net weight with the highest possible resolution

#### **10.2.10.1. MANUAL**

It will represent the net weight with the manual resolution set (in engineering units).

For example, by setting 0.1 Kg you will get that the net weight can only vary by multiples of 100g.

#### **10.2.10.2. AUTOMATIC RESOLUTION**

It will represent the net weight with a calculated resolution of about 11000 points. Unlike Maximum or Manual resolution, this setting limits also the ADC value and therefore affects all measurements.

 **CAUTION**

Keep in mind that in the "Calibration with sample weight" mode, using the "Manual Resolution", the correct sample weight value may not be perfectly represented:

For example, you have:

Cell full scale 15000 g  
Sample weight 14000 g  
Manual Resolution 1.5 g

The value of the sample weight (14000 g) cannot be represented with the resolution in 1.5g steps ( $14000/1.5g = 9333.333$  is not an integer value) so it will be represented as:  $9333 \cdot 1.5g = 13999.5g$   
To avoid this effect, use a resolution that allows the value to be represented (for example 1g or 2g).

#### 10.2.11. DIGITAL INPUT/OUTPUT SELECTION

It selects whether the Z-SG2 / Z-SG2-L digital channel is configured as an input or an output.

#### 10.2.12. DIGITAL INPUT CONFIGURATION

If the digital channel is set as an input, it is possible to select its behaviour:

##### 10.2.12.1. ACQUIRES THE TARE

In this mode, if the digital input is activated for a time longer than 3 seconds, a new tare value is acquired (in RAM, then it is lost upon restart). It is equivalent to sending the command 49594 (decimal) in the command register (see chapter 16.6).

##### 10.2.12.2. EXTERNAL DIGITAL INPUT

In this mode the status of the digital input has no effect other than the display of the status in the Modbus STATUS register.

#### 10.2.13. DIGITAL OUTPUT OPERATION MODE

If the digital channel is set as an output, you can select its behaviour:

##### 10.2.13.1. CELL FULL SCALE

In this mode the output is activated when the gross weight reaches the full scale.

##### 10.2.13.2. EXCEEDING THE THRESHOLD AND STABLE WEIGHING

In this mode the output is activated when the net weight exceeds the set threshold and the stable weighing condition is verified.

**10.2.13.3. STABLE WEIGHING**

In this mode the output is activated when the stable weighing condition is verified.

**10.2.13.4. MODBUS CONTROLLABLE**

In this mode the output can be controlled directly by modbus (see STATUS register in the chapter 16.6).

**10.2.13.5. EXCEEDED THRESHOLD WITH HYSTERESIS (ALARM)**

In this mode the output is activated when the net weight reaches the threshold, the alarm is cancelled when the net weight falls below the Threshold-Hysteresis value:

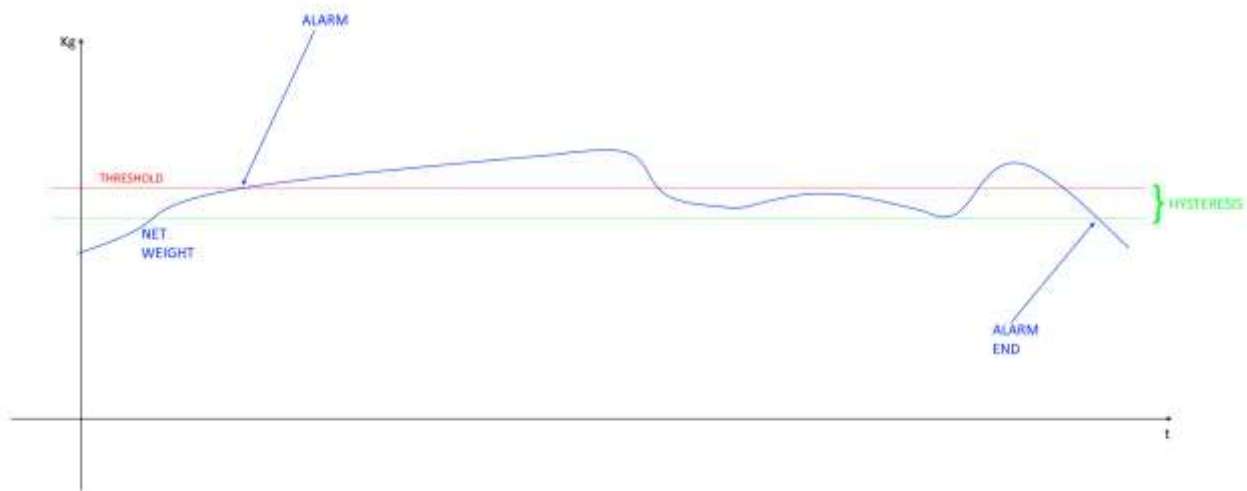

**10.2.14. STABLE WEIGHING CONDITION**

The stable weighing condition is used to indicate that the net weight measurement is stable if:

The net weight remains within the weight  $\Delta peso\_netto$  over time  $\Delta tempo$  or if the slope of the curve drawn by the net weight is less than  $\frac{\Delta peso\_netto}{\Delta tempo}$  :

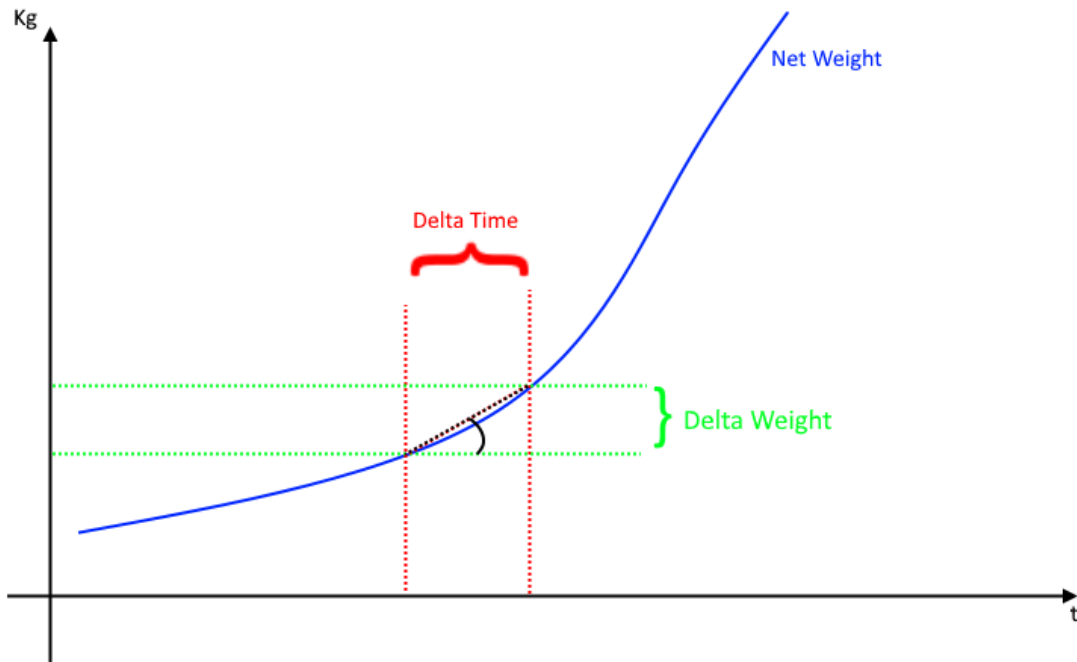

#### 10.2.14.1. DELTA WEIGHT

It is the maximum variation of the net weight accepted in the time defined by Delta Time.

#### 10.2.14.2. DELTA TIME

It is the time (in quanta of 100 ms) in which the net weight must vary less than the Delta Weight set value.

#### 10.2.15. NET WEIGHING ALARM

It is the threshold value in technical units (see 10.2.13)

#### 10.2.16. HYSTERESIS

It is the hysteresis value used in the digital output mode "EXCEEDED THRESHOLD WITH HYSTERESIS" see 10.2.13.5

#### 10.2.17. ANALOGUE OUTPUT TYPE

The analogue output follows the value of the net weight measurement, it is possible to choose between:

##### 10.2.17.1. VOLTAGE

If you select the voltage analogue output, the output can vary (depending on the configuration) between 0V and 10V.

##### 10.2.17.2. CURRENT

If the analogue current output is selected, the output can vary (depending on the configuration) between 0mA and 20mA.

**10.2.18. ANALOGUE OUTPUT CONFIGURATION**

The analogue output is completely configurable passing 4 points: two of net weight and two of analogue output:  
Example:

We would like the analogue output to be 4 mA with a net weight of 0 Kg and 20 mA with a net weight of 10 Kg:

With net weighing **0 Kg** the output must be **4 mA**

With net weighing **10 Kg** the output must be **20 mA**

Between these two points the value is linear (for example at 5 Kg the output will be 12 mA).

**10.2.19. STATION ADDRESS**

It represents the station address used in the Modbus RTU slave protocol available in the RS485 port.

**10.2.20. BAUD RATE**

It selects the baud rate to be used in the communication from the RS485 port.

**10.2.21. PARITY**

It sets whether the communication of the RS485 port must take place with or without even or odd parity.

**10.2.22. DELAY IN REPLYING**

It introduces the delay to the Modbus response in number of characters.

**10.2.23. SAMPLE WEIGHT**

It sets the weight of a single piece in technical units for the "piece weighing" mode. By setting the net weight of a single element in this register, the device will be able to indicate the number of pieces present in the scales according to the relation:

$$Nr\ pieces = \frac{Net\ Weight}{One\ Piece\ Weight}$$

**10.2.24. AUTOMATIC TARE TRACKER**

It allows to set the automatic tare reset.

**10.2.24.1. TARE TRACKER**

It allows you to enable or disable the automatic tare reset.

**10.2.24.2. ADC VALUE**

It allows to set the number of ADC points within which to reset the tare automatically.

If after 5 seconds of stable weighing condition the ADC value of the net weight deviates by less than this value then a new tare is acquired.

For example, if the tare ADC value is 5670 points and if the tare tracking ADC value is 10 points, a new tare will be acquired if the ADC value of 5675 points is stable for 5 seconds.

10.2.25. **FLOATING POINT REPRESENTATION OF THE MEASUREMENTS**

It allows to configure the type of representation of the floating point values of the measurements (while the configuration parameters do not change operation).

10.2.25.1. **FIRST PART H THEN L**

The floating point value is represented so that the most significant part is on the lowest modbus address (standard).

10.2.25.2. **FIRST PART I THEN h**

The floating point value is represented so that the most significant part is on the highest modbus address.

10.3. **DEVICE TEST**

When the configuration is sent, by pressing the



button it is possible to check the configuration sent:

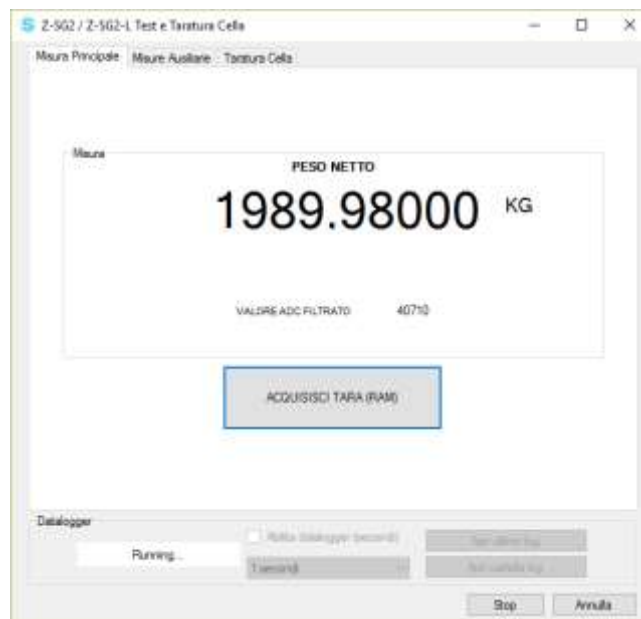

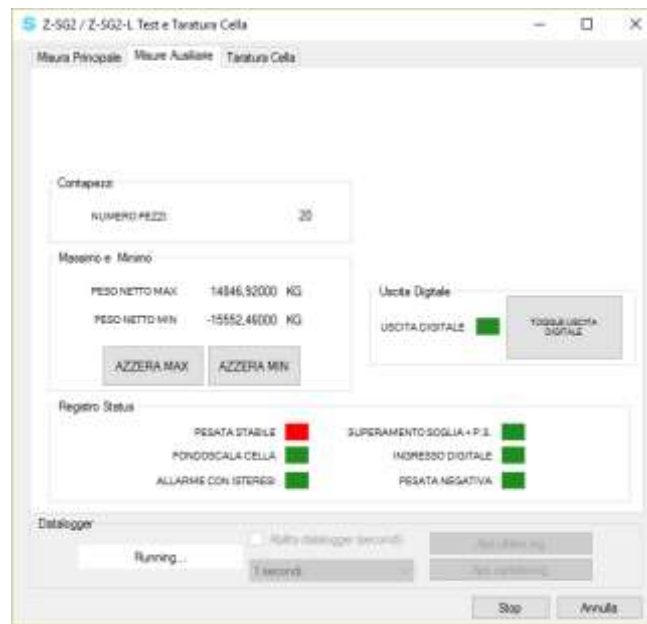

The test will continue to request registers via Modbus and it will be possible to send commands using the appropriate commands.

It is also possible to calibrate the cell or start the data logger.

### 10.3.1. THE DATA LOGGER

The data logger can be used to acquire data that can be used with external software (e.g. Microsoft Excel™).

The sample acquisition time can be set (minimum 1 second).

The data logger will create a text file in a standard .csv format.

## 11. CALIBRATION OF THE LOAD CELL WITH THE EASY SETUP SOFTWARE

In the Calibration section of the configuration test it is possible to easily calibrate a load cell.

From the main menu press the  button to enter the configuration test, now select the Cell calibration tab:

### 11.1. FACTORY CELL CALIBRATION

When factory calibrating the cell it is not necessary to use a sample weight for calibration. The data that are always required for calibration are:

- Cell sensitivity
- Cell full scale

Now you can choose how to acquire the tare choosing between:



Field or Manual.

## 11.2. FACTORY CALIBRATION WITH TARE ACQUISITION FROM THE FIELD

In the tare acquisition mode from the field, proceed as follows for calibration:

- 1) Replace the tare on the cell
- 2) Wait for the measurement to stabilize
- 3) Press the "TARE ACQUISITION (FLASH)" button

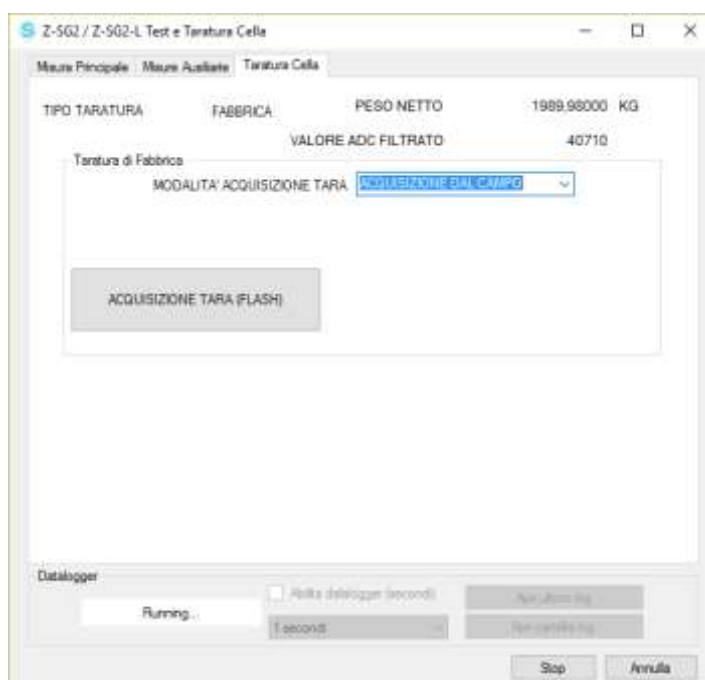

## 11.3. FACTORY CALIBRATION WITH MANUAL TARE ACQUISITION

It is not always possible to acquire the tare value from the field (for example in the case of already filled silos), in these cases it is possible to introduce the tare weight in technical units:

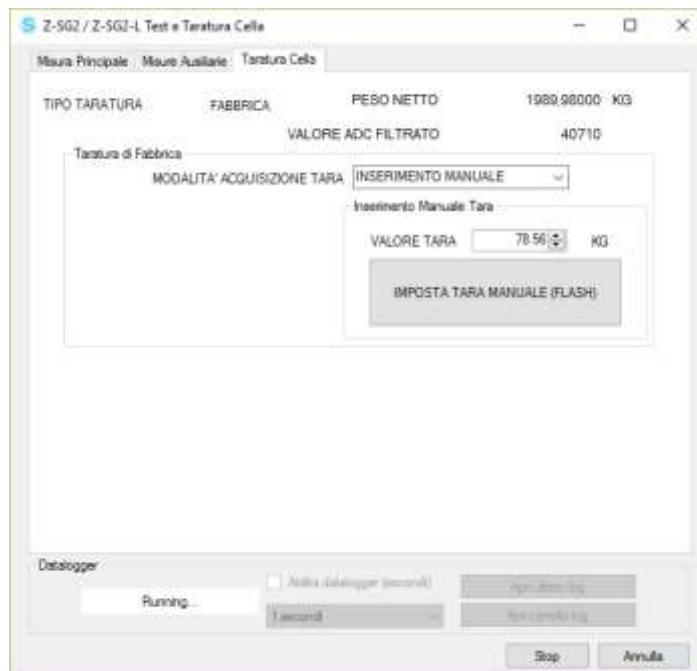

In Manual calibration mode, proceed as follows for calibration:

- 1) Set the Tare value in technical units
- 2) Press the "SET MANUAL TARE (FLASH)" button

## **ATTENTION!**

To obtain better measurement accuracy, use the tare acquisition mode from the field.

### 11.4. CELL CALIBRATION WITH A SAMPLE WEIGHT

In cell calibration with a sample weight it is necessary to have or know:

- The cell sensitivity
- The cell full scale
- A sample weight (such that its gross weight is as close as possible to the full scale)

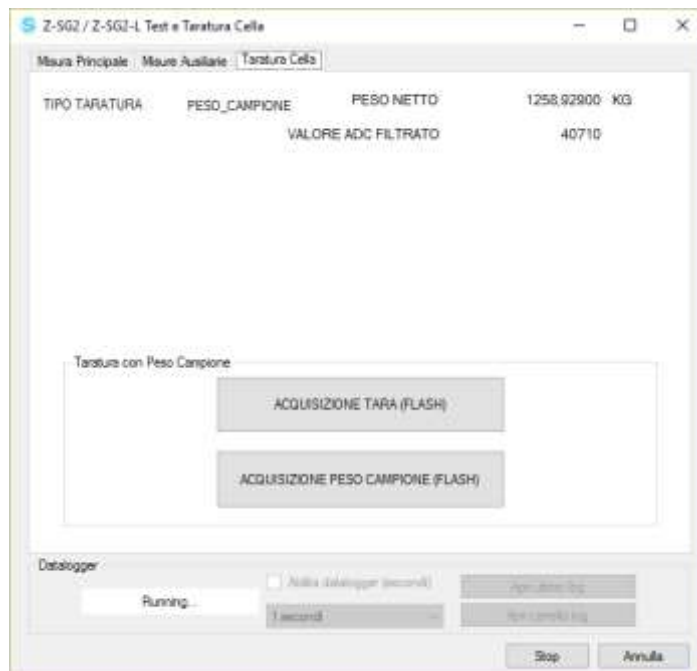

In Sample Weight mode, proceed as follows for calibration:

- 1) Replace the tare on the cell
- 2) Wait for the measurement to stabilize
- 3) Press the "TARE ACQUISITION (FLASH)" button
- 4) Replace the Tare + Sample Weight
- 5) Wait for the measurement to stabilize
- 6) Press the "SAMPLE WEIGHT ACQUISITION (FLASH)" button

## 12. USB PORT

The front USB port allows a simple connection using the Modbus RTU slave protocol, the communication parameters for the USB port cannot be modified and are:

Baud rate: 38400

Address of the Modbus RTU station: 1

Data Bit: 8

Stop bit: 1

## **ATTENTION!**

**IT IS NOT POSSIBLE TO COMMUNICATE SIMULTANEOUSLY FROM BOTH THE RS485 PORT AND THE USB PORT, THE USB PORT HAS PRIORITY (WHEN THE USB CABLE IS INSERTED, THE COMMUNICATION IS ONLY FROM THE USB).  
TO GET THE COMMUNICATION ON THE RS485 IT IS NECESSARY TO DISCONNECT THE USB CABLE.**

### 12.1. DRIVERS FOR WINDOWS SYSTEMS

Drivers for Windows systems can be downloaded from the device's web page. The drivers are however installed automatically with the installation of the "Easy Setup" software.

### 12.2. DRIVERS FOR LINUX SYSTEMS

In many Linux distributions the drivers of this port are already included (for example Raspbian for Raspberry Pi devices). It is possible to consult the web page of the device on the Seneca website for more information.

## 13. FIRMWARE UPDATE

In order to improve, add, optimize the functions of the product, Seneca releases firmware updates on the device section on the [www.seneca.it](http://www.seneca.it) website

## **ATTENTION!**

**NOT TO DAMAGE THE DEVICE DO NOT REMOVE THE POWER SUPPLY DURING THE FIRMWARE UPDATE OPERATION.**

To update the firmware in the menu, select Update Firmware-> Update:

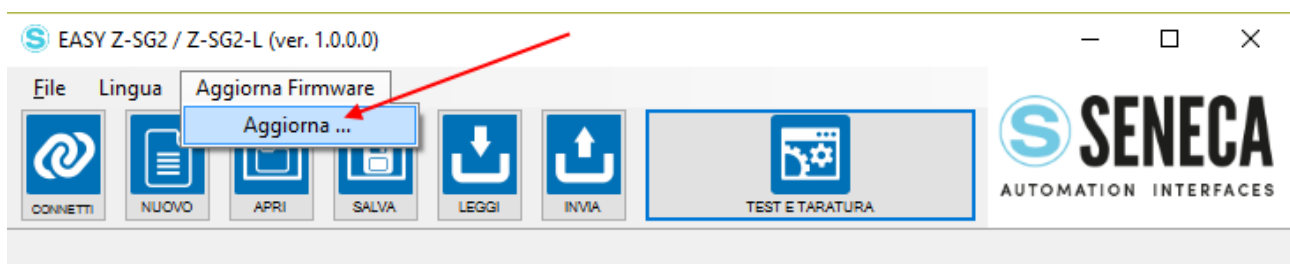

To bring the device in bootloader mode, follow the procedure below:

- 1) Remove power from the device
- 2) Keep the side button pressed
- 3) Power the device keeping the side device pressed
- 4) Wait a few seconds
- 5) Release the side button

To exit bootloader mode and return to the normal device operation, just:

- 1) Turn off the device
- 2) Power the device without pressing the side button

## **14. LOAD CELL CALIBRATION WITH MODBUS REGISTERS**

Sometimes it is not possible to use the Easy Setup software to calibrate the load cell, for example if a PLC or an HMI is to be used.

It is possible to easily implement the calibration of a load cell by sending Modbus commands depending on the type of operation chosen.

### **14.1. CALIBRATION PROCEDURE WITH AN EXTERNAL DEVICE (FACTORY CALIBRATION WITH TARE ACQUIRED FROM THE FIELD)**

- 1) Place the tare on the load cell
- 2) Wait for the measurement to stabilize
- 3) Write the decimal value 49914 in the COMMAND REGISTER
- 4) The device saves the new tare value in flash and resets the COMMAND REGISTER value
- 5) The load cell is calibrated

### **14.2. CALIBRATION PROCEDURE WITH AN EXTERNAL DEVICE (FACTORY CALIBRATION WITH MANUALLY INSERTED TARE)**

- 1) Write the tare value in technical units in the FACTORY MANUAL TARE registers
- 2) Write the decimal value 50773 in the COMMAND REGISTER
- 3) The device acquires the new flash tare value and resets the COMMAND REGISTER value
- 4) The load cell is calibrated

### **14.3. CALIBRATION PROCEDURE WITH AN EXTERNAL DEVICE (CALIBRATION WITH SAMPLE WEIGHT)**

- 1) Place the tare on the load cell
- 2) Wait for the measurement to stabilize

- 3) Write the decimal value 49914 in the COMMAND REGISTER
- 4) The device saves the new tare value in flash and resets the COMMAND REGISTER value
- 5) Enter the weight value of the sample weight in technical units in the STANDARD WEIGHT VALUE registers
- 6) Place the sample weight on the load cell
- 7) Wait for the measurement to stabilize
- 8) Write the decimal value 50700 in the COMMAND REGISTER
- 9) The device saves the new sample weight value in flash and resets the COMMAND REGISTER value
- 10) The load cell is calibrated

## 15. MODBUS RTU SLAVE COMMUNICATION PROTOCOL

The communication protocol is:

- Modbus RTU Slave (from both the RS485 and USB ports)

For more information on these protocols, see the website:

<http://www.modbus.org/specs.php>.

### 15.1. SUPPORTED MODBUS FUNCTION CODES

The following Modbus functions are supported:

- Read Holding Register (function 3)
- Write Single Register (function 6)
- Write Multiple registers (function 16)

 **ATTENTION!**

All 32-bit values are contained in 2 consecutive registers

 **ATTENTION!**

Any registers with RW\* (in flash memory) can be written up to 10000 times  
The PLC/Master Modbus programmer must not exceed this limit

## 16. MODBUS REGISTER TABLE

The following abbreviations are used in the register tables:

MS = More significant
LS = Less significant
MSW = 16 most significant bits
LSW = 16 least significant bits
MSW* = 16 most significant or least significant bits depending on the configuration (most significant default)
LSW* = 16 less significant or more significant bits depending on the configuration (less significant default)
MSW = 8 most significant bits
LSW = 8 least significant bits
MSBIT = Most significant bit
MSBIT = Least significant bit
RO = Register in read-only
RW = Read/write register
RW** = Reading and writing register contained in flash memory, writable a maximum of 10000 times.
Unsigned 16 bit = unsigned integer register, can take values from 0 to 65535
Signed 16 bit = signed integer register can take values from -32768 to +32767
Float 32 bits = 32-bit single-precision floating point register (IEEE 754) <a href="https://en.wikipedia.org/wiki/IEEE_754">https://en.wikipedia.org/wiki/IEEE_754</a>
BIT = Boolean registry, can be 0 (false) or 1 (true)

### 16.1. NUMBERING OF "0-BASED" OR "1-BASED" MODBUS ADDRESSES

According to the Modbus standard the Holding Register registers are addressable from 0 to 65535, there are 2 different conventions for numbering the addresses: "0-BASED" and "1-BASED".

For greater clarity, Seneca shows its register tables in both conventions.



## **ATTENTION!**

**CAREFULLY READ THE DOCUMENTATION OF THE MODBUS MASTER DEVICE IN ORDER TO UNDERSTAND WHICH OF THE TWO CONVENTIONS THE MANUFACTURER HAS DECIDED TO USE**

16.1.1. NUMBERING OF MODBUS ADDRESSES WITH "0-BASED" CONVENTION

The numbering is:

<b>HOLDING REGISTER MODBUS ADDRESS (OFFSET)</b>	<b>MEANING</b>
0	FIRST REGISTER
1	SECOND REGISTER
2	THIRD REGISTER
3	FOURTH REGISTER
4	FIFTH REGISTER

Therefore the first register is at address 0.

In the following tables, this convention is indicated with "**ADDRESS OFFSET**".

16.1.2. NUMBERING OF MODBUS ADDRESSES WITH "1 BASED" CONVENTION (STANDARD)

The numbering is that established by the Modbus consortium and is of the type:

<b>HOLDING REGISTER MODBUS ADDRESS 4x</b>	<b>MEANING</b>
40001	FIRST REGISTER
40002	SECOND REGISTER
40003	THIRD REGISTER
40004	FOURTH REGISTER
40005	FIFTH REGISTER

In the following tables this convention is indicated with "**ADDRESS 4x**" since a 4 is added to the address so that the first Modbus register is 40001.

A further convention is also possible where the number 4 is omitted in front of the register address:

<b>HOLDING MODBUS ADDRESS WITHOUT 4x</b>	<b>MEANING</b>
1	FIRST REGISTER
2	SECOND REGISTER
3	THIRD REGISTER
4	FOURTH REGISTER
5	FIFTH REGISTER



**16.2. BIT CONVENTION WITHIN A MODBUS HOLDING REGISTER**

A Modbus Holding Register consists of 16 bits with the following convention:

BIT 15	BIT 14	BIT 13	BIT 12	BIT 11	BIT 10	BIT 9	BIT 8	BIT 7	BIT 6	BIT 5	BIT 4	BIT 3	BIT 2	BIT 1	BIT 0
-----------	-----------	-----------	-----------	-----------	-----------	----------	----------	----------	----------	----------	----------	----------	----------	----------	----------

For instance, if the value of the register in decimal is

12300

the value 12300 in hexadecimal is:

0x300C

the hexadecimal 0x300C in binary value is:

11 0000 0000 1100

So, using the above convention, we get:

BIT 15	BIT 14	BIT 13	BIT 12	BIT 11	BIT 10	BIT 9	BIT 8	BIT 7	BIT 6	BIT 5	BIT 4	BIT 3	BIT 2	BIT 1	BIT 0
0	0	1	1	0	0	0	0	0	0	0	0	1	1	0	0

**16.3. MSB and LSB BYTE CONVENTION WITHIN A MODBUS HOLDING REGISTER**

A Modbus Holding Register consists of 16 bits with the following convention:

BIT 15	BIT 14	BIT 13	BIT 12	BIT 11	BIT 10	BIT 9	BIT 8	BIT 7	BIT 6	BIT 5	BIT 4	BIT 3	BIT 2	BIT 1	BIT 0
-----------	-----------	-----------	-----------	-----------	-----------	----------	----------	----------	----------	----------	----------	----------	----------	----------	----------

LSB Byte (Least Significant Byte) defines the 8 bits ranging from Bit 0 to Bit 7 included, we define MSB Byte (Most Significant Byte) the 8 bits ranging from Bit 8 to Bit 15 inclusive:

BIT 15	BIT 14	BIT 13	BIT 12	BIT 11	BIT 10	BIT 9	BIT 8	BIT 7	BIT 6	BIT 5	BIT 4	BIT 3	BIT 2	BIT 1	BIT 0
BYTE MSB								BYTE LSB							

### 16.4. REPRESENTATION OF A 32-BIT VALUE IN TWO CONSECUTIVE MODBUS HOLDING REGISTERS

The representation of a 32-bit value in the Modbus Holding Registers is made using 2 consecutive Holding Registers (a Holding Register is a 16-bit register). To obtain the 32-bit value it is therefore necessary to read two consecutive registers:

For example, if register 40064 contains the 16 most significant bits (MSW) while register 40065 contains the least significant 16 bits (LSW), the 32-bit value is obtained by composing the 2 registers:

BIT	BIT	BIT	BIT	BIT	BIT	BIT	BIT	BIT	BIT	BIT	BIT	BIT	BIT	BIT	BIT
15	14	13	12	11	10	9	8	7	6	5	4	3	2	1	0
40064 MOST SIGNIFICANT WORD															

BIT	BIT	BIT	BIT	BIT	BIT	BIT	BIT	BIT	BIT	BIT	BIT	BIT	BIT	BIT	BIT
15	14	13	12	11	10	9	8	7	6	5	4	3	2	1	0
40065 LEAST SIGNIFICANT WORD															

$$Value_{32bit} = Register_{LSW} + (Register_{MSW} * 65536)$$

In the reading registers it is possible to swap the most significant word with the least significant word, therefore it is possible to obtain 40064 as LSW and 40065 as MSW.

### 16.5. TYPE OF 32-BIT FLOATING POINT DATA (IEEE 754)

The IEEE 754 standard ([https://en.wikipedia.org/wiki/IEEE\\_754](https://en.wikipedia.org/wiki/IEEE_754)) defines the format for representing floating point numbers.

As already mentioned, since it is a 32-bit data type, its representation occupies two 16-bit holding registers.

To obtain a binary / hexadecimal conversion of a floating point value it is possible to refer to an online converter at this address:

<http://www.h-schmidt.net/FloatConverter/IEEE754.html>

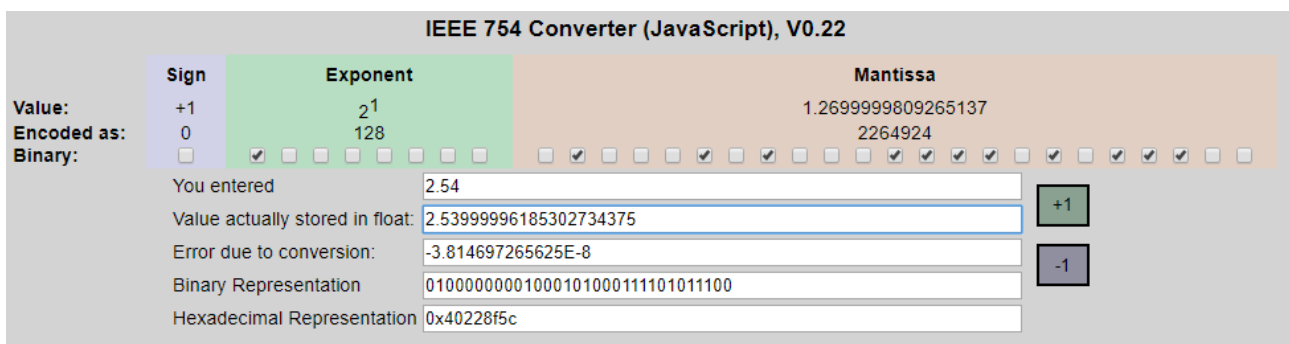

The screenshot shows the IEEE 754 Converter interface. The input value is 2.54. The interface displays the IEEE 754 representation with the following fields:

- Sign:** +1
- Exponent:** 2<sup>1</sup> (128)
- Mantissa:** 1.2699999809265137 (2264924)

Below the bit fields, the following information is provided:

- You entered: 2.54
- Value actually stored in float: 2.53999996185302734375
- Error due to conversion: -3.814697265625E-8
- Binary Representation: 0100000001000101000111101011100
- Hexadecimal Representation: 0x40228f5c

Using the last representation the value 2.54 is represented at 32 bits as:

0x40228F5C

Since we have 16-bit registers available, the value must be divided into MSW and LSW:

0x4022 (16418 decimal) are the 16 most significant bits (MSW) while 0x8F5C (36700 decimal) are the 16 least significant bits (LSW).

**16.6. Z-SG2 / Z-SG2-L: MODBUS 4X HOLDING REGISTERS TABLE (FUNCTION CODE 3)**

INDIRIZZO (4x)	OFFSET INDIRIZZO	REGISTRO	DESCRIZIONE	W/R	TIPO
40001	0	MACHINE-ID	IDENTIFICATIVO DEVICE	RO	UNSIGNED 16 BIT
40002	1	FIRMWARE REVISION	REVISIONE FIRMWARE	RO	UNSIGNED 16 BIT
40003	2	UNIT / UNIPOLAR	<p>(MSB) UNIT Seleziona l'unità di misura tra 0=Kg 1=g 2=t 3=lb 4=l 5=N 6=bar 7=atm 8=Altro</p> <p>(LSB) UNIPOLAR 0 = ADC Configurato in Trazione e Compressione (bipolare) 1 = ADC Configurato in Compressione (unipolare)</p>	RW**	UNSIGNED 16 BIT
40004	3	RS485 MODBUS STATION / RS485 PARITY	<p>(MSB) Modbus Station: E' il Modbus station address della porta RS485</p> <p>(LSB) Parity: Imposta la parità della comunicazione Modbus della porta RS485</p> <p>0=No parità 1 = Pari 2 = Dispari</p>	RW**	UNSIGNED 16 BIT

INDIRIZZO (4x)	OFFSET INDIRIZZO	REGISTRO	DESCRIZIONE	W/R	TIPO
40005	4	RS485 BAUD RATE / RS485 DELAY	(MSB) Baud Rate: Seleziona il baud Rate della RS485 0= 4800 1 = 9600 2=19200 3=38400 4=57600 5=115200 6 = RISERVATO 7= 2400  (LSB) DELAY RS485: Ritardo alla risposta Modbus in numero di caratteri	RW**	UNSIGNED 16 BIT
40006	5	OUTPUT STOP SCALE [V / mA]	Valore di fine scala dell'uscita analogica in [V/mA] (MSW)	RW**	FLOATING POINT 32 BIT
40007	6		Valore di fine scala dell'uscita analogica in [V/mA] (LSW)	RW**	
40008	7	OUTPUT START SCALE [V / mA]	Valore di inizio scala dell'uscita analogica in [V/mA] (MSW)	RW**	FLOATING POINT 32 BIT
40009	8		Valore di inizio scala dell'uscita analogica in [V/mA] (LSW)	RW**	
40010	9	DIGITAL IN-OUT / ANALOG OUT TYPE	(MSB) DIGITAL IN-OUT: 0 = Canale digitale configurato come Ingresso 1 = Canale digitale configurato come Uscita  (LSB) ANALOG OUT TYPE: 0 = Uscita analogica in tensione 1 = Uscita analogica in corrente	RW**	UNSIGNED 16 BIT

INDIRIZZO (4x)	OFFSET INDIRIZZO	REGISTRO	DESCRIZIONE	W/R	TIPO
40011	10	DIGITAL INPUT TYPE / CALIBRATION MODE	(MSB) DIGITAL INPUT TYPE: Seleziona il funzionamento dell'ingresso digitale 0 = L'ingresso digitale acquisisce la tara 1 = Lo stato dell'ingresso digitale è mostrato su Modbus senza effetti  (LSB) CALIBRATION MODE: Imposta il tipo di funzionamento e della taratura 0=Usa la taratura di Fabbrica 1=Usa la taratura con un peso campione	RW**	UNSIGNED 16 BIT
40029	28	CELL SENSE RATIO [mV/V]	Valore di targa della sensibilità della cella di carico in [mV/V] (MSW)	RW**	FLOATING POINT 32 BIT
40030	29		Valore di targa della sensibilità della cella di carico in [mV/V] (MSW)	RW**	
40031	30	CELL FULL SCALE [kg/g/t...]	Valore di fondo scala della cella di carico in unità tecniche (MSW)	RW**	FLOATING POINT 32 BIT
40032	31		Valore di fondo scala della cella di carico in unità tecniche (LSW)	RW**	
40033	32	STANDARD WEIGHT VALUE [kg/g/t...]	Valore del peso campione in unità tecniche da utilizzare nella modalità di taratura con peso campione (MSW)	RW**	FLOATING POINT 32 BIT
40034	33		Valore del peso campione in unità tecniche da utilizzare nella modalità di taratura con peso campione (LSW)	RW**	
40035	34	OUTPUT WEIGHT STOP SCALE [kg/g/t...]	Valore di fine scala del peso netto per l'uscita analogica in unità tecniche (MSW)	RW**	FLOATING POINT 32 BIT

INDIRIZZO (4x)	OFFSET INDIRIZZO	REGISTRO	DESCRIZIONE	W/R	TIPO
40036	35		Valore di fine scala del peso netto per l'uscita analogica in unità tecniche (LSW)	RW**	
40037	36	OUTPUT WEIGHT START SCALE [kg/g/t...]	Valore di inizio scala del peso netto per l'uscita analogica (MSW)	RW**	FLOATING POINT 32 BIT
40038	37		Valore di inizio scala del peso netto per l'uscita analogica (LSW)	RW**	
40039	38	THRESHOLD [kg/g/t...]	Valore della soglia di allarme in unità tecniche (MSW)	RW**	FLOATING POINT 32 BIT
40040	39		Valore della soglia di allarme in unità tecniche (LSW)	RW**	
40041	40	$\Delta$ WEIGHT [kg/g/t...]	Valore del delta peso in unità tecniche per la condizione di pesata stabile (MSW)	RW**	FLOATING POINT 32 BIT
40042	41		Valore del delta peso in unità tecniche per la condizione di pesata stabile (LSW)	RW**	
40043	42	$\Delta$ TIME	Valore del delta tempo in quanti di 100ms per la condizione di pesata stabile	RW**	UNSIGNED 16 BIT
40044	43	DIGITAL OUT NCNO / DIGITAL OUT MODE	(MSB) DIGITAL OUT NCNO: 0 = Uscita digitale normalmente aperta 1 = Uscita digitale normalmente chiusa  (LSB) DIGITAL OUT MODE: 0 = Attiva su superamento Fondoscala cella 1= Attiva su superamento soglia + pesata stabile 2 = Attiva su Pesata Stabile 3 = Comandabile da Modbus 4 = Attiva su Superamento soglia con isteresi	RW**	UNSIGNED 16 BIT

INDIRIZZO (4x)	OFFSET INDIRIZZO	REGISTRO	DESCRIZIONE	W/R	TIPO
40045	44	ADVANCED ADC SPEED	<p>Configura la velocità di campionamento dell'ADC.</p> <p>Per maggiori informazioni fare riferimento a 10.2.9.3</p> <p>E' attivo solo se si imposta il filtraggio a livello 7 (avanzato).</p>	RW**	UNSIGNED 16 BIT
40046	45	ADVANCED MOVING AVERAGE	<p>Rappresenta il numero di campioni nella media mobile da 1 a 100</p> <p>E' attivo solo se si imposta il filtraggio a livello 7 (avanzato).</p>	RW**	UNSIGNED 16 BIT
40047	46	ADVANCED ADC CHOPPING	<p>Abilita o Disabilita la modalità ADC Chopping.</p> <p>Per maggiori informazioni fare riferimento a 10.2.9.2</p> <p>E' attivo solo se si imposta il filtraggio a livello 7 (avanzato) e nella modalità taratura con peso campione.</p> <p>0 = Disabilita ADC Chopping 1 = Abilita ADC Chopping</p>	RW**	UNSIGNED 16 BIT
40048	47	AUTOMATIC TARE RESET	<p>0 = Disabilita l'inseguitore di tara</p> <p>Se <math>\geq 1</math> è il valore di punti ADC entro il quale azzerare la tara in automatico.</p> <p>Se dopo 5 secondi di condizione di pesata stabile il valore ADC del peso netto si discosta di meno di questo valore allora viene acquisita una nuova tara.</p>	RW**	UNSIGNED 16 BIT



INDIRIZZO (4x)	OFFSET INDIRIZZO	REGISTRO	DESCRIZIONE	W/R	TIPO
40049	48	THRESHOLD HYSTERESIS [kg/g/t...]	E' il valore di isteresi per l'allarme di superamento soglia (MSW)	RW**	FLOATING POINT 32 BIT
40050	49		E' il valore di isteresi per l'allarme di superamento soglia (LSW)	RW**	
40051	50	ADVANCED DENOISE FILTER VARIATION	Rappresenta la variazione in punti ADC dovuta al solo rumore. E' attivo solo se si imposta il filtraggio a livello 7 (avanzato). (MSW)	RW**	FLOATING POINT 32 BIT
40052	51		Rappresenta la variazione in punti ADC dovuta al solo rumore. E' attivo solo se si imposta il filtraggio a livello 7 (avanzato). (LSW)	RW**	
40053	52	ADVANCED DENOISE FILTER RESPONSE	Rappresenta un parametro relativo alla velocità di risposta del filtro può variare da 0.001 (Risposta più lenta) a 1 (Risposta più veloce). E' attivo solo se si imposta il filtraggio a livello 7 (avanzato). (MSW)	RW**	FLOATING POINT 32 BIT
40054	53		Rappresenta un parametro relativo alla velocità di risposta del filtro può variare da 0.001 (Risposta più lenta) a 1 (Risposta più veloce). E' attivo solo se si imposta il filtraggio a livello 7 (avanzato). (LSW)	RW**	

INDIRIZZO (4x)	OFFSET INDIRIZZO	REGISTRO	DESCRIZIONE	W/R	TIPO																		
40055	54	DENOISE FILTER VALUE	<p>E' possibile configurare un livello di filtro prestabilito:</p> <table border="1"> <thead> <tr> <th>LIVELLO DEL FILTRO</th> <th>TEMPO DI RISPOSTA [ms]</th> </tr> </thead> <tbody> <tr> <td>0</td> <td>16</td> </tr> <tr> <td>1</td> <td>32</td> </tr> <tr> <td>2</td> <td>50</td> </tr> <tr> <td>3</td> <td>250</td> </tr> <tr> <td>4</td> <td>400 (default)</td> </tr> <tr> <td>5</td> <td>900</td> </tr> <tr> <td>6</td> <td>1800</td> </tr> <tr> <td>7 "AVANZATO"</td> <td>Dipendente dalla configurazione</td> </tr> </tbody> </table> <p>Più è alto il livello di filtro più la misura di peso sarà stabile ma lenta. Un valore diverso da 7 sovrascriverà i parametri avanzati. Nella modalità "Avanzato" sarà possibile agire sui singoli parametri del filtro ADVANCED MOVING AVERAGE, ADVANCED NOISE FILTER VARIATION, ADVANCED NOISE FILTER RESPONSE ADVANCED ADC CHOPPER</p>	LIVELLO DEL FILTRO	TEMPO DI RISPOSTA [ms]	0	16	1	32	2	50	3	250	4	400 (default)	5	900	6	1800	7 "AVANZATO"	Dipendente dalla configurazione	RW**	UNSIGNED 16 BIT
LIVELLO DEL FILTRO	TEMPO DI RISPOSTA [ms]																						
0	16																						
1	32																						
2	50																						
3	250																						
4	400 (default)																						
5	900																						
6	1800																						
7 "AVANZATO"	Dipendente dalla configurazione																						

INDIRIZZO (4x)	OFFSET INDIRIZZO	REGISTRO	DESCRIZIONE	W/R	TIPO
40056	55	RESOLUTION MODE / DENOISE FILTER ENABLE	<p>RESOLUTION MODE (MSB)</p> <p>Seleziona il tipo di risoluzione da utilizzare nella sola misura di Peso Netto tra:</p> <p>0=Risoluzione massima 1=Risoluzione manuale (registro MANUAL RESOLUTION) 2= Risoluzione Automatica (calcolata in base al fondoscala per ottenere 10000 punti)</p> <p>DENOISE FILTER ENABLE (LSB)</p> <p>0 = Filtro anti rumore disabilitato (modalità avanzata) 1 = Filtro anti rumore abilitato</p>	RW**	UNSIGNED 16 BIT
40057	56	MANUAL RESOLUTION [kg/g/t...]	Imposta la risoluzione manuale con cui è visualizzata la misura di peso netto in unità tecniche (MSW)	RW**	FLOATING POINT 32 BIT
40058	57		Imposta la risoluzione manuale con cui è visualizzata la misura di peso netto in unità tecniche (LSW)	RW**	
40059	58	ONE PIECE WEIGHT [kg/g/t...]	Imposta il peso di un singolo pezzo da utilizzare quando si utilizza il contapezzi (MSW)	RW**	FLOATING POINT 32 BIT
40060	59		Imposta il peso di un singolo pezzo da utilizzare quando si utilizza il contapezzi (LSW)	RW**	
40061	60	FLOATING POINT ORDER	Seleziona se i registri RO in formato floating point vengono visualizzati nei registri modbus in H/L o L/H: 0 = Visualizza i registri in H/L 1 = Visualizza i registri in L/H	RW**	UNSIGNED 16 BIT

INDIRIZZO (4x)	OFFSET INDIRIZZO	REGISTRO	DESCRIZIONE	W/R	TIPO
40062	61	16 BIT ADC FILTERED	<p>Valore dell'ADC filtrato e scalato a 16 bit</p> <p>Nel caso di misura Unipolare può variare da 0 a 65535</p> <p>Nel caso di misura Bipolare Può variare da 0 (max trazione) a 32767 (min trazione)</p> <p>Da 32768 (condizione di 0 o riposo) a 65535 (max compressione)</p>	RO	UNSIGNED 16
40063	62	RESERVED	-	RO	UNSIGNED 16
40064	63	NET WEIGHT [kg/g/t...]	Valore della pesata Netta in unità tecniche (MSW*)	RO	FLOATING POINT 32 BIT
40065	64		Valore della pesata Netta in unità tecniche (LSW*)	RO	
40066	65	GROSS WEIGHT [kg/g/t...]	Valore della pesata Lorda in unità tecniche (MSW*)	RO	FLOATING POINT 32 BIT
40067	66		Valore della pesata Lorda in unità tecniche (LSW*)	RO	
40068	67	TARE WEIGHT [kg/g/t...]	Valore della tara in unità tecniche (MSW*)	RO	FLOATING POINT 32 BIT
40069	68		Valore della tara in unità tecniche (LSW*)	RO	
40070	69	INTEGER NET WEIGHT [kg/g/t...]	Valore della pesata Netta in unità tecniche (MSW)	RO	SIGNED 32 BIT
40071	70		Valore della pesata Netta in unità tecniche (LSW)	RO	
40072	71	INTEGER GROSS WEIGHT [kg/g/t...]	Valore della pesata Lorda in unità tecniche (MSW)	RO	SIGNED 32 BIT
40073	72		Valore della pesata Lorda in unità tecniche (LSW)	RO	
40074	73	INTEGER TARE WEIGHT [kg/g/t...]	Valore della tara in unità tecniche (MSW)	RO	SIGNED 32 BIT
40075	74		Valore della tara in unità tecniche (LSW)	RO	

INDIRIZZO (4x)	OFFSET INDIRIZZO	REGISTRO	DESCRIZIONE	W/R	TIPO
40076	75	FACTORY MANUAL TARE [kg/g/t...]	Valore da utilizzare per la tara manuale nella modalità taratura di fabbrica (MSW*)	RO	FLOATING POINT 32 BIT
40077	76		Valore da utilizzare per la tara manuale nella modalità taratura di fabbrica (LSW*)	RO	

INDIRIZZO (4x)	OFFSET INDIRIZZO	REGISTRO	DESCRIZIONE	W/R	TIPO
40078	77		<p>Registro di stato:</p> <p>BIT 0 LSBIT (RO)            Bit 0 = 1 Superamento Soglia            + Pesata stabile</p> <p>BIT 1 (RO)            Bit 1 = 1            La cella ha raggiunto il            fondoscala</p> <p>BIT 2 (RO)            Bit 2 = 1            Il peso netto è &lt; 0</p> <p>BIT 3 (RO)            Riservato</p> <p>BIT 4 (RO)            Bit 4 = 1            La pesata è stabile</p> <p>BIT 5 (R/W)</p> <p>Solo se è stata scelta la            modalità uscita comandabile            da modbus:</p> <p>Bit 5 = 1            L'uscita digitale è attivata            Bit 5 = 0            L'uscita digitale è disattivata</p> <p>BIT 6 (RO)            Bit 6 = 1 se l'ingresso digitale            è alto</p> <p>BIT 7 (RO)            Bit 7 = 1 Superamento Soglia            con isteresi</p> <p>BIT 8 (RO)            Bit 8 = 1 L'inseguitore di tara            è intervenuto (se abilitato)</p> <p>BIT 9..15            Non usati</p>	R/W	UNSIGNED 16 BIT
40079	78	RESERVED	-	RO	UNSIGNED 16 BIT

INDIRIZZO (4x)	OFFSET INDIRIZZO	REGISTRO	DESCRIZIONE	W/R	TIPO
40080	79	COMMAND REGISTER	<p>Registro comandi, una volta eseguito il comando il registro ritorna al valore 0</p> <p>43948 (decimale) Esegue un riavvio del dispositivo</p> <p>49594 (decimale) Acquisisce la tara in RAM (al riavvio viene persa)</p> <p>49914 (decimale) Acquisisce la tara in Flash per la procedura di taratura in entrambe le modalità di funzionamento (taratura di fabbrica e con peso campione)</p> <p>50700 (decimale) Acquisisce il valore del peso campione in Flash per la taratura con peso campione</p> <p>50773 (decimale) Acquisisce il valore della tara dal registro MANUAL TARE (solo per la modalità taratura di fabbrica)</p> <p>49151 (decimale) Azzera il registro con il massimo peso netto</p> <p>45056 (decimale) Azzera il registro con il minimo peso netto</p>	R/W	UNSIGNED 16 BIT
40081	80	PIECES NR	E' il registro dove è conteggiato il numero di pezzi	RO	UNSIGNED 16 BIT

INDIRIZZO (4x)	OFFSET INDIRIZZO	REGISTRO	DESCRIZIONE	W/R	TIPO
40082	81	MAX NET WEIGHT [kg/g/t...]	Valore Massimo della peso netto in unità tecniche dal riavvio (MSW*)	RO	FLOATING POINT 32 BIT
40083	82		Valore Massimo della peso netto in unità tecniche dal riavvio (LSW*)	RO	
40084	83	MIN NET WEIGHT [kg/g/t...]	Valore Minimo della peso netto in unità tecniche dal riavvio (MSW*)	RO	FLOATING POINT 32 BIT
40085	84		Valore Minimo della peso netto in unità tecniche dal riavvio (LSW*)	RO	
40086	85	RESERVED	-	RO	UNSIGNED 16 BIT
40087	86	RESERVED	-	RO	UNSIGNED 16 BIT
40088	87	RESERVED	-	RO	UNSIGNED 16 BIT
40089	88	RESERVED	-	RO	UNSIGNED 16 BIT
40090	89	RESERVED	-	RO	UNSIGNED 16 BIT
40091	90	RESERVED	-	RO	UNSIGNED 16 BIT
40092	91	ADC RAW 24 BIT	Valore dell'ADC a 24 bit non filtrato (MSW)	RO	UNSIGNED 32 (MODALITA' UNIPOLARE)
40093	92		Valore dell'ADC a 24 bit non filtrato (LSW)	RO	SIGNED 32 (MODALITA' BIPOLARE)